

REVISIONS													
LTR	DESCRIPTION	DATE (YR-MO-DA)	APPROVED										
REV													
SHEET													
REV													
SHEET													
REV STATUS OF SHEETS	REV												
	SHEET	1	2	3	4	5	6	7	8	9			
PMIC N/A	PREPARED BY <i>Monica L. Felling</i>		DEFENSE ELECTRONICS SUPPLY CENTER DAYTON, OHIO 45444										
STANDARDIZED MILITARY DRAWING THIS DRAWING IS AVAILABLE FOR USE BY ALL DEPARTMENTS AND AGENCIES OF THE DEPARTMENT OF DEFENSE AMSC N/A	CHECKED BY <i>Ray Monnin</i>		MICROCIRCUITS, DIGITAL, BIPOLAR, ADVANCED SCHOTTKY, QUAD 2-INPUT, POSITIVE AND GATES, MONOLITHIC SILICON										
	APPROVED BY <i>[Signature]</i>		SIZE A	CAGE CODE 67268	5962-88723								
	DRAWING APPROVAL DATE 06 SEP 1988		REVISION LEVEL SHEET 1 OF 9										

DESC FORM 193
SEP 87

• U.S. GOVERNMENT PRINTING OFFICE: 1987 — 748-129/60911
5962-E1033

DISTRIBUTION STATEMENT A. Approved for public release; distribution is unlimited.

1. SCOPE

1.1 Scope. This drawing describes device requirements for class B microcircuits in accordance with 1.2.1 of MIL-STD-883, "Provisions for the use of MIL-STD-883 in conjunction with compliant non-JAN devices".

1.2 Part number. The complete part number shall be as shown in the following example:

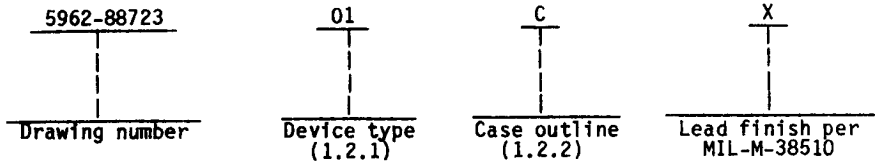

1.2.1 Device type. The device type shall identify the circuit function as follows:

Device type	Generic number	Circuit function
01	54F09	Quadruple, 2-input positive AND gates with open collector outputs

1.2.2 Case outlines. The case outlines shall be as designated in appendix C of MIL-M-38510, and as follows:

Outline letter	Case outline
C	D-1 (14-lead, .785" x .310" x .200"), dual-in-line package
D	F-2 (14-lead, .390" x .260" x .085"), flat package
2	C-2 (20-terminal, .358" x .358" x .100"), square chip carrier package

1.3 Absolute maximum ratings.

Supply voltage range - - - - -	-0.5 V dc minimum to +7.0 V dc maximum
Input voltage range - - - - -	-1.2 V dc at -18 mA to +7.0 V dc
Input current range - - - - -	-30 mA to +5.0 mA
Voltage applied to any output in the high state - - - - -	-0.5 V dc to V_{CC}
Current into any output in the low state - - - - -	+40 mA
Storage temperature range - - - - -	-65°C to +150°C
Lead temperature (soldering, 10 seconds) - - - - -	+300°C
Junction temperature (T_J) - - - - -	+175°C
Maximum power dissipation (P_D) ^{1/} - - - - -	+70.4 mW

1.4 Recommended operating conditions.

Supply voltage range (V_{CC}) - - - - -	+4.5 V dc minimum to +5.5 V dc maximum
Minimum high level input voltage (V_{IH}) - - - - -	2.0 V dc
Maximum low level input voltage (V_{IL}) - - - - -	0.8 V dc
Input clamp current (I_{IC}) - - - - -	-18 mA
High level output voltage (V_{OH}) - - - - -	5.5 V
Low level output current (I_{OL}) - - - - -	20 mA
Case operating temperature range (T_C) - - - - -	-55°C to +125°C

^{1/} Maximum power dissipation is defined as $V_{CC} \times I_{CC}$.

STANDARDIZED MILITARY DRAWING DEFENSE ELECTRONICS SUPPLY CENTER DAYTON, OHIO 45444	SIZE A	5962-88723
	REVISION LEVEL	SHEET 2

2. APPLICABLE DOCUMENTS

2.1 Government specification and standard. Unless otherwise specified, the following specification and standard, of the issue listed in that issue of the Department of Defense Index of Specifications and Standards specified in the solicitation, form a part of this drawing to the extent specified herein.

SPECIFICATION

MILITARY

MIL-M-38510 - Microcircuits, General Specification for.

STANDARD

MILITARY

MIL-STD-883 - Test Methods and Procedures for Microelectronics.

(Copies of the specification and standard required by manufacturers in connection with specific acquisition functions should be obtained from the contracting activity or as directed by the contracting activity.)

2.2 Order of precedence. In the event of a conflict between the text of this drawing and the references cited herein, the text of this drawing shall take precedence.

3. REQUIREMENTS

3.1 Item requirements. The individual item requirements shall be in accordance with 1.2.1 of MIL-STD-883, "Provisions for the use of MIL-STD-883 in conjunction with compliant non-JAN devices" and as specified herein.

3.2 Design, construction, and physical dimensions. The design, construction, and physical dimensions shall be as specified in MIL-M-38510 and herein.

3.2.1 Terminal connections. The terminal connections shall be as specified on figure 1.

3.2.2 Truth table. The truth table shall be as specified on figure 2.

3.2.3 Test circuit and switching waveforms. The test circuit and switching waveforms shall be as specified on figure 3.

3.2.4 Case outlines. The case outlines shall be in accordance with 1.2.2 herein.

3.3 Electrical performance characteristics. Unless otherwise specified, the electrical performance characteristics are as specified in table I and apply over the full case operating temperature range.

3.4 Marking. Marking shall be in accordance with MIL-STD-883 (see 3.1 herein). The part shall be marked with the part number listed in 1.2 herein. In addition, the manufacturer's part number may also be marked as listed in 6.4 herein.

STANDARDIZED MILITARY DRAWING DEFENSE ELECTRONICS SUPPLY CENTER DAYTON, OHIO 45444	SIZE A		5962-88723
		REVISION LEVEL	SHEET 3

DESC FORM 193A
SEP 87

* U. S. GOVERNMENT PRINTING OFFICE: 1968-549-804

TABLE I. Electrical performance characteristics.

Test	Symbol	Conditions -55°C < T _C < +125°C unless otherwise specified		Group A subgroups	Limits		Unit
					Min	Max	
High level output current	I _{OH}	V _{CC} = 4.5 V	V _{OH} = 5.5 V	1, 2, 3		0.1	mA
Low level output voltage	V _{OL}	V _{IL} = 0.8 V V _{IH} = 2.0 V	V _{CC} = 4.5 V I _{OL} = 20 mA	1, 2, 3		0.5	V
Input clamp voltage	V _{IC}	V _{CC} = 4.5 V	I _{IN} = -18 mA	1, 2, 3		-1.2	V
High level input current	I _{IH1}	V _{CC} = 5.5 V	V _{IN} = 7.0 V	1, 2, 3		0.1	mA
	I _{IH2}		V _{IN} = 2.7 V			20	μA
Low level input current	I _{IL}	V _{IN} = 0.5 V	V _{CC} = 5.5 V	1, 2, 3		-0.6	mA
Supply current	I _{CCH}	V _{CC} = 5.5 V	V _{IN} = 4.5 V	1, 2, 3		7.8	mA
	I _{CCL}		V _{IN} = 0.0 V			12.8	mA
Functional tests		See 4.3.1c		7, 8			
Propagation delay time, from A, B to Y	t _{PLH}	V _{CC} = 4.5 V to 5.5 V C _L = 50 pF R _L = 500Ω See figure 3		9, 10, 11	5.0	10.5	ns
	t _{PHL}				1.5	6.0	

STANDARDIZED MILITARY DRAWING DEFENSE ELECTRONICS SUPPLY CENTER DAYTON, OHIO 45444	SIZE A		5962-88723
		REVISION LEVEL	SHEET 4

DESC FORM 193A
SEP 87

* U. S. GOVERNMENT PRINTING OFFICE: 1986-549-904

3.5 Certificate of compliance. A certificate of compliance shall be required from a manufacturer in order to be listed as an approved source of supply in 6.4. The certificate of compliance submitted to DESC-ECS prior to listing as an approved source of supply shall state that the manufacturer's product meets the requirements of MIL-STD-883 (see 3.1 herein) and the requirements herein.

3.6 Certificate of conformance. A certificate of conformance as required in MIL-STD-883 (see 3.1 herein) shall be provided with each lot of microcircuits delivered to this drawing.

3.7 Notification of change. Notification of change to DESC-ECS shall be required in accordance with MIL-STD-883 (see 3.1 herein).

3.8 Verification and review. DESC, DESC's agent, and the acquiring activity retain the option to review the manufacturer's facility and applicable required documentation. Offshore documentation shall be made available onshore at the option of the reviewer.

4. QUALITY ASSURANCE PROVISIONS

4.1 Sampling and inspection. Sampling and inspection procedures shall be in accordance with section 4 of MIL-M-38510 to the extent specified in MIL-STD-883 (see 3.1 herein).

4.2 Screening. Screening shall be in accordance with method 5004 of MIL-STD-883, and shall be conducted on all devices prior to quality conformance inspection. The following additional criteria shall apply:

a. Burn-in test, method 1015 of MIL-STD-883.

(1) Test condition A or D using the circuit submitted with the certificate of compliance (see 3.5 herein).

(2) $T_A = +125^\circ\text{C}$, minimum.

b. Interim and final electrical test parameters shall be as specified in table II herein, except interim electrical parameter tests prior to burn-in are optional at the discretion of the manufacturer.

4.3 Quality conformance inspection. Quality conformance inspection shall be in accordance with method 5005 of MIL-STD-883 including groups A, B, C, and D inspections. The following additional criteria shall apply.

4.3.1 Group A inspection.

a. Tests shall be as specified in table II herein.

b. Subgroups 4, 5, and 6 in table I, method 5005 of MIL-STD-883 shall be omitted.

c. Subgroups 7 and 8 tests shall verify the truth table as specified on figure 2 herein.

4.3.2 Groups C and D inspections.

a. End-point electrical parameters shall be as specified in table II herein.

b. Steady-state life test conditions, method 1005 of MIL-STD-883.

(1) Test condition A or D using the circuit submitted with the certificate of compliance (see 3.5 herein).

(2) $T_A = +125^\circ\text{C}$, minimum.

(3) Test duration: 1,000 hours, except as permitted by method 1005 of MIL-STD-883.

STANDARDIZED MILITARY DRAWING DEFENSE ELECTRONICS SUPPLY CENTER DAYTON, OHIO 45444	SIZE A	5962-88723
	REVISION LEVEL	SHEET 5

DESC FORM 193A
SEP 87

★ U. S. GOVERNMENT PRINTING OFFICE: 1988-548-904

Cases outlines	C and D	2
Pin numbers	Terminal connections	
1	1A	NC
2	1B	1A
3	1Y	1B
4	2A	1Y
5	2B	NC
6	2Y	2A
7	GND	NC
8	3Y	2B
9	3A	2Y
10	3B	GND
11	4Y	NC
12	4A	3Y
13	4B	3A
14	VCC	3B
15	---	NC
16	---	4Y
17	---	NC
18	---	4A
19	---	4B
20	---	VCC

NC = No connection

FIGURE 1. Terminal connections.

Inputs		Output
A	B	Y
H	H	H
L	X	L
X	L	L

H = High voltage level
L = Low voltage level
X = Irrelevant

FIGURE 2. Truth table.

STANDARDIZED MILITARY DRAWING DEFENSE ELECTRONICS SUPPLY CENTER DAYTON, OHIO 45444	SIZE A	5962-88723
	REVISION LEVEL	SHEET 6

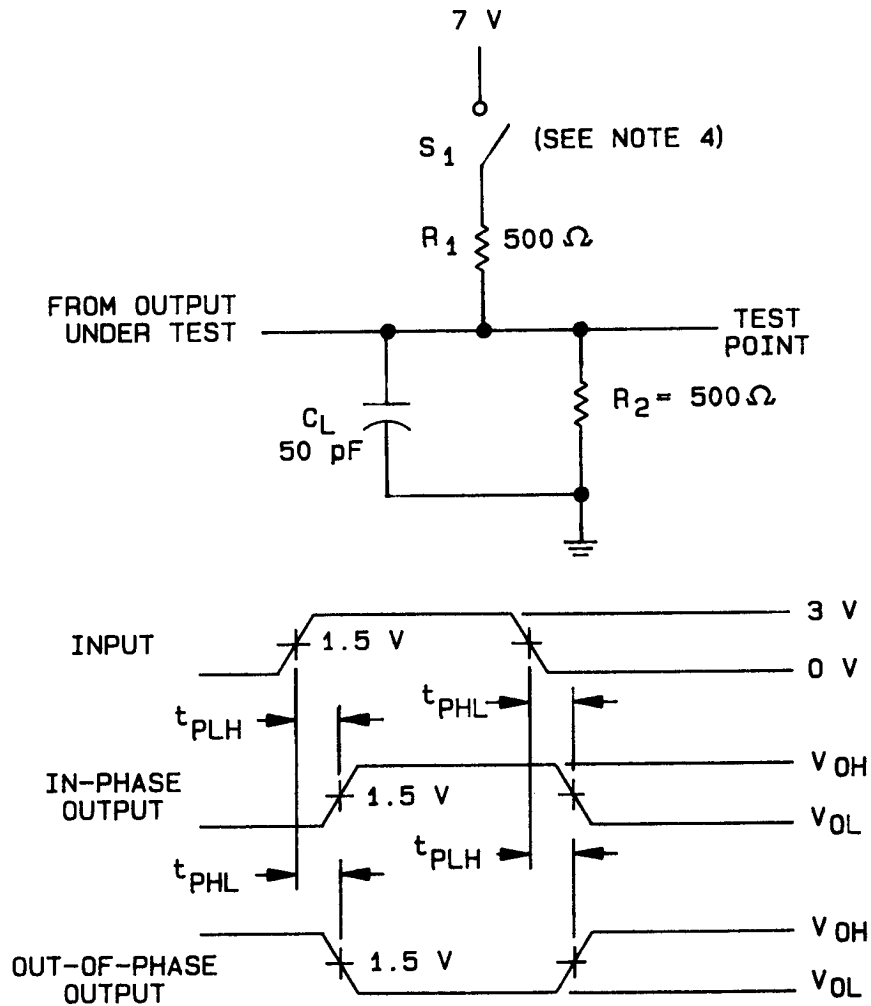

NOTES:

1. C_L includes probe and jig capacitance.
2. Input pulses are supplied by generators having the following characteristics: PRR = 1 MHz, duty cycle = 50%, $t_r = t_f = 2.5$ ns.
3. The outputs are measured one at a time with one transition per measurement.
4. The switch is closed for open collector outputs.

FIGURE 3. Test circuit and switching waveforms.

STANDARDIZED MILITARY DRAWING DEFENSE ELECTRONICS SUPPLY CENTER DAYTON, OHIO 45444	SIZE A	5962-88723
	REVISION LEVEL	SHEET 7

DESC FORM 193A
SEP 87

☆ U.S. GOVERNMENT PRINTING OFFICE: 1987-548-096

TABLE II. Electrical test requirements.

MIL-STD-883 test requirements	Subgroups (per method 5005, table I)
Interim electrical parameters (method 5004)	---
Final electrical test parameters (method 5004)	1*, 2, 3, 7, 8, 9, 10, 11
Groups A test requirements (method 5005)	1, 2, 3, 7, 8, 9, 10, 11
Group C and D end-point electrical parameters (method 5005)	1, 2, 3

*PDA applies to subgroup 1.

5. PACKAGING

5.1 Packaging requirements. The requirements for packaging shall be in accordance with MIL-M-38510.

6. NOTES

6.1 Intended use. Microcircuits conforming to this drawing are intended for use when military specifications do not exist and qualified military devices that will perform the required function are not available for OEM application. When a military specification exists and the product covered by this drawing has been qualified for listing on QPL-38510, the device specified herein will be inactivated and will not be used for new design. The QPL-38510 product shall be the preferred item for all applications.

6.2 Replaceability. Microcircuits covered by this drawing will replace the same generic device covered by a contractor-prepared specification or drawing.

6.3 Comments. Comments on this drawing should be directed to DESC-ECS, Dayton, Ohio 45444, or telephone 513-296-5375.

STANDARDIZED MILITARY DRAWING DEFENSE ELECTRONICS SUPPLY CENTER DAYTON, OHIO 45444	SIZE A	5962-88723
	REVISION LEVEL	SHEET 8

6.4 Approved source of supply. An approved source of supply is listed herein. Additional sources will be added as they become available. The vendor listed herein has agreed to this drawing and a certificate of compliance (see 3.5 herein) has been submitted to DESC-ECS.

Military drawing part number	Vendor CAGE number	Vendor similar part number <u>1/</u>
5962-8872301CX	01295	SNJ54F09J
5962-8872301DX	01295	SNJ54F09W
5962-88723012X	01295	SNJ54F09FK

1/ Caution. Do not use this number for item acquisition. Items acquired to this number may not satisfy the performance requirements of this drawing.

Vendor CAGE number

01295

Vendor name and address

Texas Instruments, Incorporated
P.O. Box 6448
Midland, TX 79711

STANDARDIZED MILITARY DRAWING DEFENSE ELECTRONICS SUPPLY CENTER DAYTON, OHIO 45444	SIZE A		5962-88723
		REVISION LEVEL	SHEET 9

DESC FORM 193A
SEP 87

* U. S. GOVERNMENT PRINTING OFFICE: 1988-548-904