

FEATURES

- Standard 9x14mm Surface Mount Footprint
- Output frequency from 6.4 MHz to 20 MHz
- CMOS/TTL Compatible
- Temperature Stability, ± 0.280 ppm Max
- Stratum 3 Holdover per GR-1244
- +3.3 or +5 Vdc Operation
- Operating Temperature to 0°C to +70°C
- Output Enable Standard
- Electrical Frequency Adjustment Option
- Tape & Reel Packaging
- **RoHS Compliant** – Fully compliant to RoHS Directive 2002/95/EC

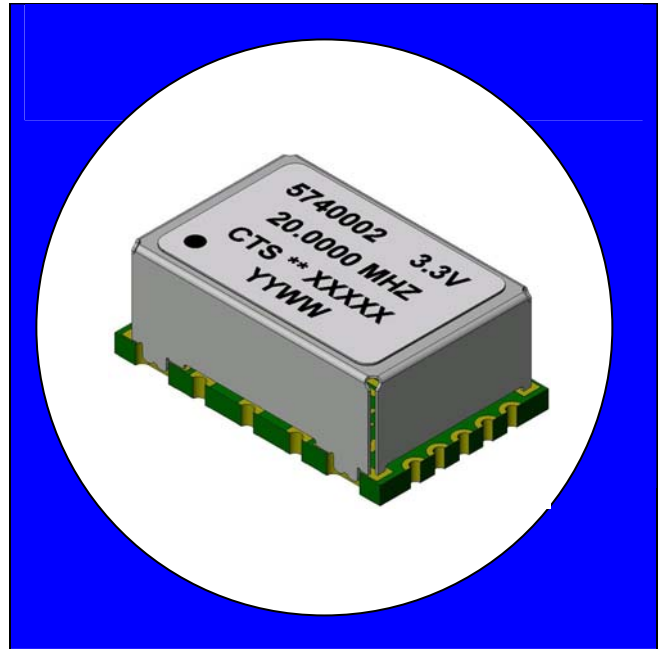

DESCRIPTION

The MODEL 574 TCXO/TCVCXO offers reduced size and enhanced stability, including Stratum 3 stability and holdover per GR-1244. The small size means it is perfect for most applications. The enhanced stability means it is the perfect choice for today's communications applications that require tight frequency control.

ELECTRICAL CHARACTERISTICS

	PARAMETER	SYMBOL	CONDITIONS	MIN	TYP	MAX	UNIT
Electrical and Waveform Parameters	Maximum Supply Voltage Range	V_{CC}	-	2.4	-	5.5	V
	Storage Temperature	T_{STG}	-	-55	-	125	°C
	Frequency	f_0	-	6.4	10.0, 12.8, 16.384, 19.44, 20.0	20	MHz
	Initial Frequency Accuracy @ 25°C	$\Delta f/f_0$	At time of Shipment $V_C @ 0.5 V_{CC}$ (with Vcontrol option)	-	0.1	±0.25	ppm
	Operating Temperature	T_A	-	0	25	70	°C
	Temperature Stability	$\Delta f/f_0$	-	-	±0.20	±0.28	ppm
	Operating Supply Voltage	V_{CC}	±5%	3.135 4.75	3.300 5.00	3.465 5.25	V
	Supply Current	I_{CC}	$C_L = 15$ pf $V_{CC} +5\%$	-	6	10	mA
	Output Load	C_L	Output to Ground	-	15	-	pF
	Output Voltage Levels						
	Logic '1' Level	V_{OH}	$C_L = 15$ pf	0.9 V_{CC}	0.95 V_{CC}	-	V
	Logic '0' Level	V_{OL}	$C_L = 15$ pf	-	0.1 V_{CC}	0.5	V
	Output Current						mA
	Logic '1' Level	I_{OH}	$V_{OH} = 0.9 V_{CC}, V_{CC}$ @typical	-	-	-8	mA
	Logic '0' Level	I_{OL}	$V_{OL} = 0.1 V_{CC}, V_{CC}$ @typical	-	-	+8	mA
	Output Duty Cycle	SYM	@ 50% Waveform Level	45	-	55	%
	Rise and Fall Time		from 10% to 90% of waveform	-	3	6	ns
	Start Up Time	T_S	Output level to 90%	-	-	2	ms
	Enable Function	V_{IO}	Pin 2 No Connect , Output Enabled				
	Enable Input Voltage	V_{IH}	Pin 2 Logic '1', Output Enabled	0.7 V_{CC}	-	-	V
	Disable Input Voltage	V_{IL}	Pin 2 Logic '0', Output Disabled	-	-	0.3 V_{CC}	V
	Pushing		$V_{CC} \pm 5\%$	-	±0.050	±0.100	ppm
	Pulling		$C_L = 15$ pF ±10%	-	±0.050	±0.100	ppm
	Vcontrol OPTION (0.5 V_{CC} VDC nominal)	V_C	$V_C = 0.1 V_{CC}$ to 0.9 V_{CC} Positive, monotonic slope	±9.2	±12	±18	ppm
	Vc Input Impedance	Zin		100	-	-	K ohms
	24 hour holdover		$T_A = 0^\circ\text{C}$ to $+70^\circ\text{C}$, $V_{CC} \pm 5\%$, and 24 hours aging	-	±0.300	±0.350	ppm
	Lifetime accuracy 20 years		All factors (ref. to f_0)	-	±4.0	±4.6	ppm
	Aging						
			One Year Aging	-	0.5	-	ppm
			Twenty Year Aging	-	2.5	4.0	ppm
	Phase Noise						
		10Hz	-	-85	-80	dBc	
		100Hz	-	-115	-110	dBc	
		1Khz	-	-140	-135	dBc	
		10Khz	-	-155	-150	dBc	
		Noise floor	-	-160	-150	dBc	
Phase Jitter	tjms	Bandwidth 12 kHz - 20 MHz	-	0.4	1.0	ps RMS	

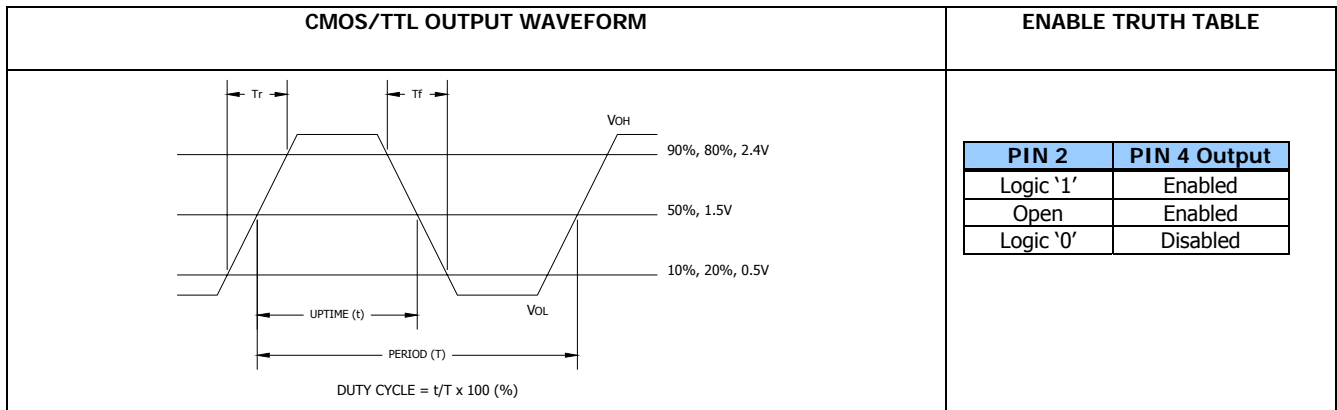

MECHANICAL SPECIFICATIONS

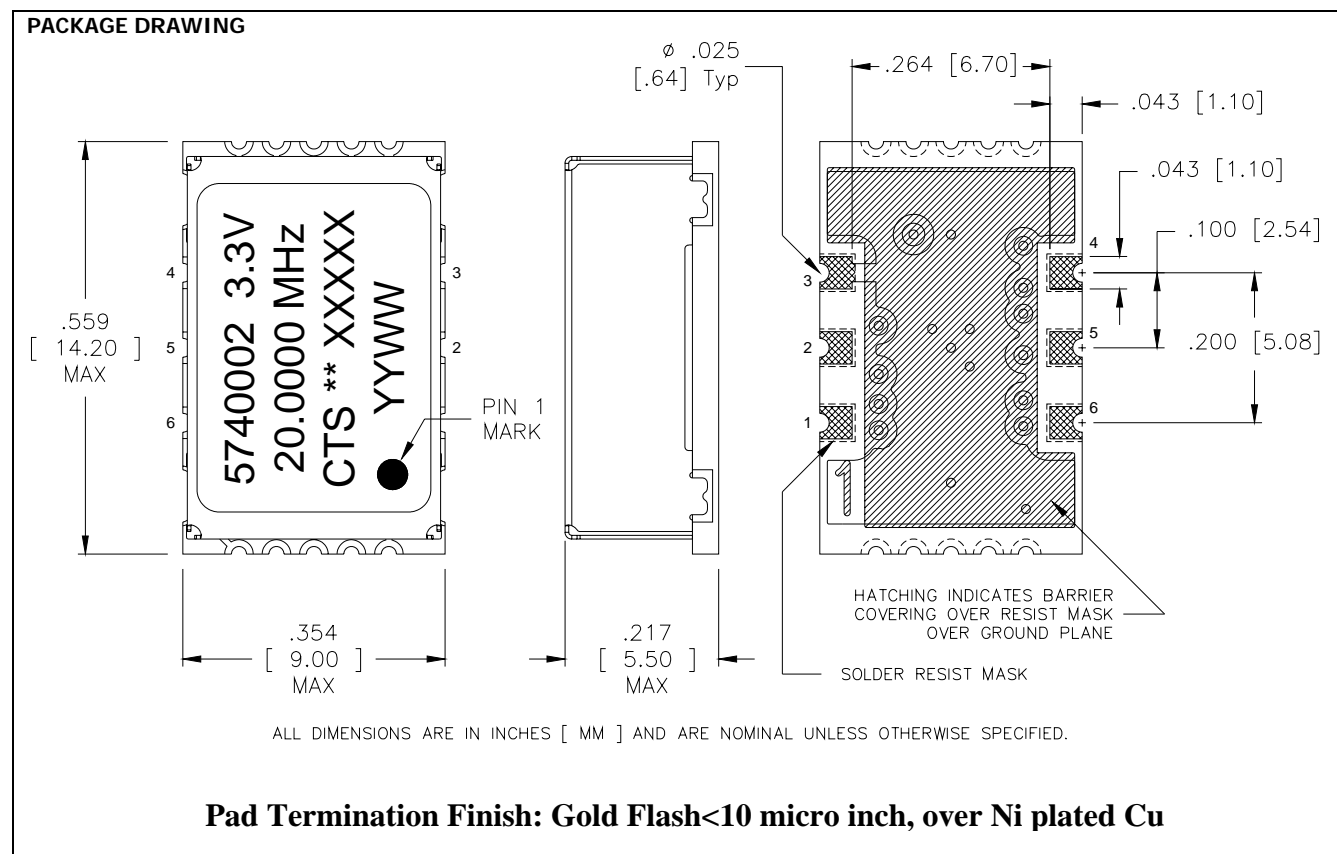

MARKING INFORMATION

1. ** - Manufacturing Site Code, XXXXX-Lot Number.
2. YYWW – Date Code, YY – Year, WW – Week.

PIN ASSIGNMENT

1. V Control or NC
2. Output Enable
3. GND
4. CMOS output
5. NC
6. V_{CC}

SUGGESTED SOLDER PAD GEOMETRY

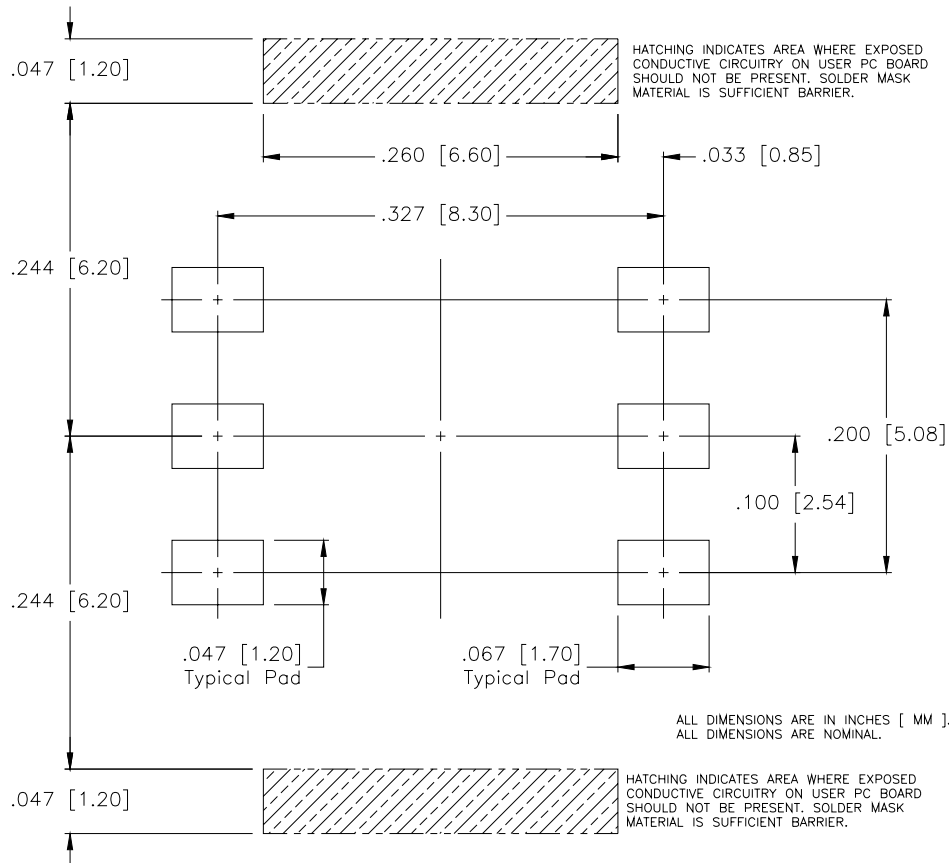

Dimensions are in [mm] and inches.

MAXIMUM SOLDERING PROFILE

Temperature	>25°C	>100°C	>120°C	>183°C	260°C (Absolute max temperature)
Time	14min	9min	6min	2.5min	10 seconds max

Note: Device is not designed to be reflowed in an inverted position.

TAPE AND REEL INFORMATION

DIMENSIONS IN MILLIMETERS

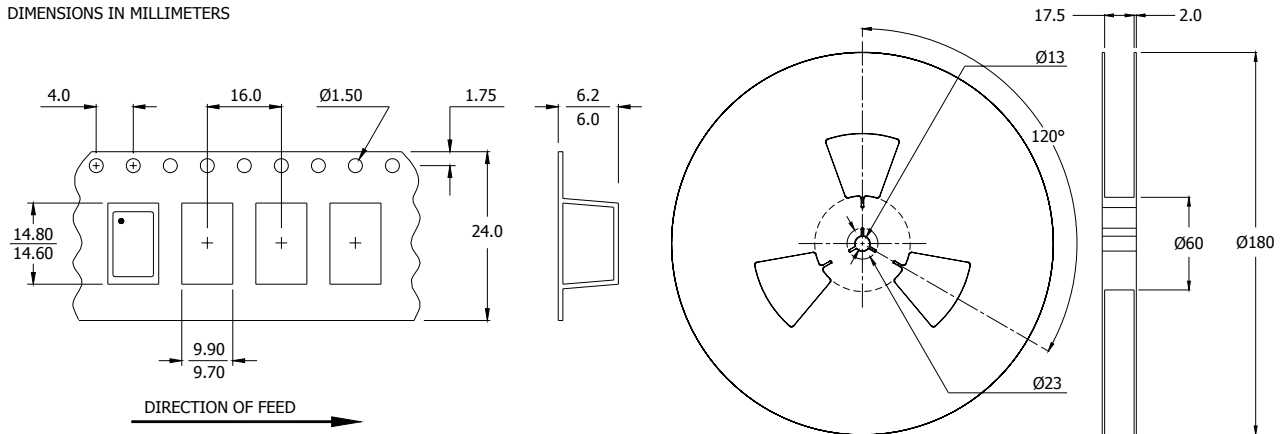

Device quantity is 500 pieces maximum per 180mm reel.

ENVIRONMENTAL SPECIFICATIONS

Temperature Cycle:	400 cycles from -55°C to $+125^{\circ}\text{C}$, 10 minute dwell at each temperature, 1 minute transfer time between temperatures.
Mechanical Shock:	1,500g's, 0.5mS duration, 1/2 sinewave, 3 shocks each direction along 3 mutually perpendicular planes (18 total shocks).
Sinusoidal Vibration:	0.06 inches double amplitude, 10 to 55 Hz and 20g's, 55 to 2,000 Hz, 3 cycles each in 3 mutually perpendicular planes (9 times total).
Resistance to Solder Heat:	3 reflows of $+260^{\circ}\text{C}$ peak, 10 seconds maximum per each.
High Temperature Operating Bias:	1,000 hours at $+125^{\circ}\text{C}$, maximum bias, disregarding frequency shift.
Frequency Aging:	1,000 hours at $+85^{\circ}\text{C}$, full bias, less than ± 2 ppm shift.
MSL:	Level 1

QUALITY AND RELIABILITY

Quality systems meet or exceed the requirements of ISO 9000:2000 standards. Reliability audits are performed on this or similar products with results available upon request.