

MOTOROLA
SEMICONDUCTOR
 TECHNICAL DATA

Designer's Data Sheet
Power Field Effect Transistor
N-Channel Enhancement-Mode
Silicon Gate
DPAK for Surface Mount
or Insertion Mount



MTD6N10

TMOS POWER FET
 6 AMPERES
 $R_{DS(on)} = 0.25 \text{ OHM}$
 80 and 100 VOLTS

This TMOS Power FET is designed for high speed, low loss power switching applications such as switching regulators, converters, solenoid and relay drivers.

- Silicon Gate for Fast Switching Speeds
- Low $R_{DS(on)}$ — 0.25 Ω max
- Rugged — SOA is Power Dissipation Limited
- Source-to-Drain Diode Characterized for Use With Inductive Loads
- Low Drive Requirement — $V_{GS(th)} = 4 \text{ V}$ max
- Surface Mount Package on 16 mm Tape
- Available With Long Leads, Add -1 Suffix

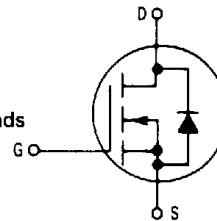

3

MAXIMUM RATINGS

| Rating | Symbol | Value | Unit |
|--|----------------|-------------|---------------------|
| Drain-Source Voltage | V_{DSS} | 100 | Vdc |
| Drain-Gate Voltage ($R_{GS} = 1 \text{ M}\Omega$) | V_{DGR} | 100 | Vdc |
| Gate-Source Voltage — Continuous | V_{GS} | ± 20 | Vdc |
| — Non-repetitive ($t_p \leq 50 \mu\text{s}$) | V_{GSM} | ± 40 | Vpk |
| Drain Current — Continuous | I_D | 6 | Adc |
| — Pulsed | I_{DM} | 20 | |
| Total Power Dissipation @ $T_C = 25^\circ\text{C}$ | P_D | 20 | Watts |
| Derate above 25°C | | 0.16 | W/ $^\circ\text{C}$ |
| Total Power Dissipation @ $T_A = 25^\circ\text{C}$ | P_D | 1.25 | Watts |
| Derate above 25°C | | 0.01 | W/ $^\circ\text{C}$ |
| Total Power Dissipation @ $T_A = 25^\circ\text{C}$ (1) | P_D | 1.75 | Watts |
| Derate above 25°C | | 0.014 | W/ $^\circ\text{C}$ |
| Operating and Storage Junction Temperature Range | T_J, T_{stg} | -65 to +150 | $^\circ\text{C}$ |

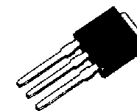

CASE 369-06
 TO-251
 MTD6N10-1

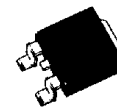

CASE 369A-10
 TO-252
 MTD6N10

THERMAL CHARACTERISTICS

| | | | |
|---------------------------------------|---------------------------|-----------------|--------------------|
| Thermal Resistance — Junction to Case | $R_{\theta JC}$ | 6.25 | $^\circ\text{C/W}$ |
| | — Junction to Ambient | $R_{\theta JA}$ | 100 |
| | — Junction to Ambient (1) | | 71.4 |

ELECTRICAL CHARACTERISTICS ($T_C = 25^\circ\text{C}$ unless otherwise noted)

| Characteristic | Symbol | Min | Max | Unit |
|----------------|--------|-----|-----|------|
|----------------|--------|-----|-----|------|

OFF CHARACTERISTICS

| | | | | |
|--|---------------|-----|-----------|-----------------|
| Drain-Source Breakdown Voltage ($V_{GS} = 0, I_D = 0.25 \text{ mA}$) | $V_{(BR)DSS}$ | 100 | — | Vdc |
| Zero Gate Voltage Drain Current ($V_{DS} = \text{Rated } V_{DSS}, V_{GS} = 0$) $T_J = 125^\circ\text{C}$ | I_{DSS} | — | 10 100 | μAdc |

(1) These ratings are applicable when surface mounted on the minimum pad size recommended. (continued)

Designer's Data for "Worst Case" Conditions — The Designer's Data Sheet permits the design of most circuits entirely from the information presented. Limit curves — representing boundaries on device characteristics — are given to facilitate "worst case" design.

MTD6N10

ELECTRICAL CHARACTERISTICS — continued ($T_C = 25^\circ\text{C}$ unless otherwise noted)

| Characteristic | Symbol | Min | Max | Unit |
|----------------|--------|-----|-----|------|
|----------------|--------|-----|-----|------|

OFF CHARACTERISTICS — continued

| | | | | |
|--|------------|---|-----|------|
| Gate-Body Leakage Current, Forward ($V_{GSF} = 20\text{ Vdc}, V_{DS} = 0$) | I_{GSSF} | — | 100 | nAdc |
| Gate-Body Leakage Current, Reverse ($V_{GSR} = 20\text{ Vdc}, V_{DS} = 0$) | I_{GSSR} | — | 100 | nAdc |

ON CHARACTERISTICS*

| | | | | |
|---|--------------|----------|------------|------|
| Gate Threshold Voltage ($V_{DS} = V_{GS}, I_D = 1\text{ mA}$) $T_J = 100^\circ\text{C}$ | $V_{GS(th)}$ | 2 1.5 | 4.5 4 | Vdc |
| Static Drain-Source On-Resistance ($V_{GS} = 10\text{ Vdc}, I_D = 3\text{ Adc}$) | $R_{DS(on)}$ | — | 0.25 | Ohm |
| Drain-Source On-Voltage ($V_{GS} = 10\text{ V}$) ($I_D = 6\text{ Adc}$) ($I_D = 3\text{ Adc}, T_J = 100^\circ\text{C}$) | $V_{DS(on)}$ | — — | 1.6 1.5 | Vdc |
| Forward Transconductance ($V_{DS} = 15\text{ V}, I_D = 3\text{ A}$) | g_{FS} | 1 | — | mhos |

DYNAMIC CHARACTERISTICS

| | | | | | |
|------------------------------|--|-----------|---|-----|----|
| Input Capacitance | $(V_{DS} = 25\text{ V}, V_{GS} = 0,$ $f = 1\text{ MHz}$ See Figure 11) | C_{iss} | — | 600 | pF |
| Output Capacitance | | C_{oss} | — | 400 | |
| Reverse Transfer Capacitance | | C_{rss} | — | 80 | |

SWITCHING CHARACTERISTICS* ($T_J = 100^\circ\text{C}$)

| | | | | | |
|---------------------|--|--------------|----------|-----|----|
| Turn-On Delay Time | $(V_{DD} = 25\text{ V}, I_D = 0.5\text{ Rated } I_D$ $R_{gen} = 50\text{ ohms}$ See Figures 13 and 14) | $t_{d(on)}$ | — | 50 | ns |
| Rise Time | | t_r | — | 150 | |
| Turn-Off Delay Time | | $t_{d(off)}$ | — | 100 | |
| Fall Time | | t_f | — | 50 | |
| Total Gate Charge | $(V_{DS} = 0.8\text{ Rated } V_{DSS},$ $I_D = \text{Rated } I_D, V_{GS} = 10\text{ V}$ See Figure 12) | Q_g | 13 (Typ) | 30 | nC |
| Gate-Source Charge | | Q_{gs} | 6 (Typ) | — | |
| Gate-Drain Charge | | Q_{gd} | 7 (Typ) | — | |

SOURCE DRAIN DIODE CHARACTERISTICS*

| | | | | | |
|-----------------------|---|----------|-----------------------------|---|-----|
| Forward On-Voltage | $(I_S = \text{Rated } I_D$ $V_{GS} = 0)$ | V_{SD} | 1.7 (Typ) | 3 | Vdc |
| Forward Turn-On Time | | t_{on} | Limited by stray inductance | | |
| Reverse Recovery Time | | t_{rr} | 100 (Typ) | — | ns |

*Pulse Test Pulse Width $\leq 300\ \mu\text{s}$, Duty Cycle $\leq 2\%$

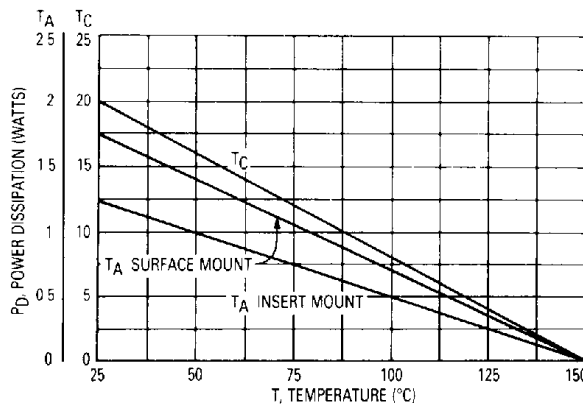

Figure 1. Power Derating

TYPICAL ELECTRICAL CHARACTERISTICS

3

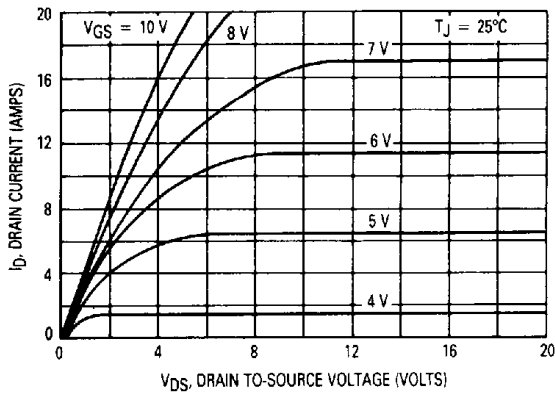

Figure 2. On-Region Characteristics

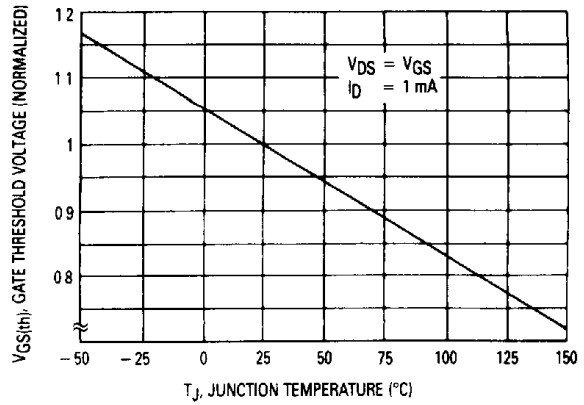

Figure 3. Gate-Threshold Voltage Variation With Temperature

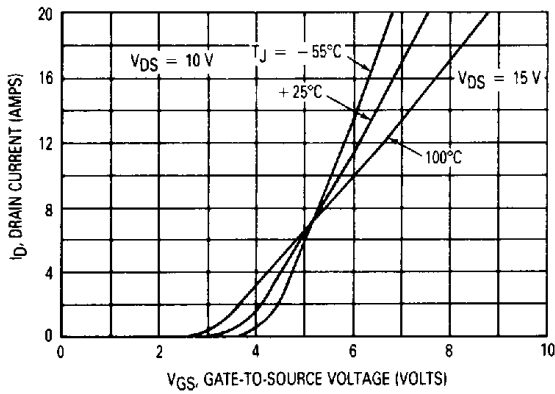

Figure 4. Transfer Characteristics

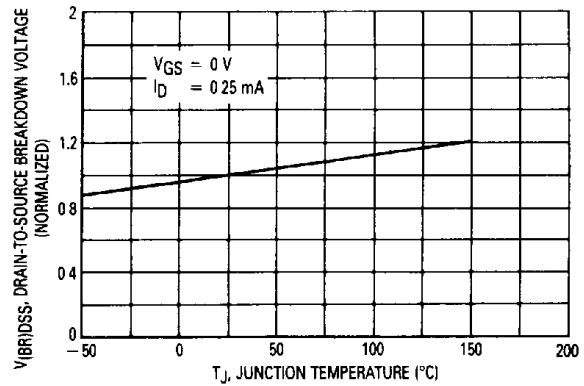

Figure 5. Breakdown Voltage Variation With Temperature

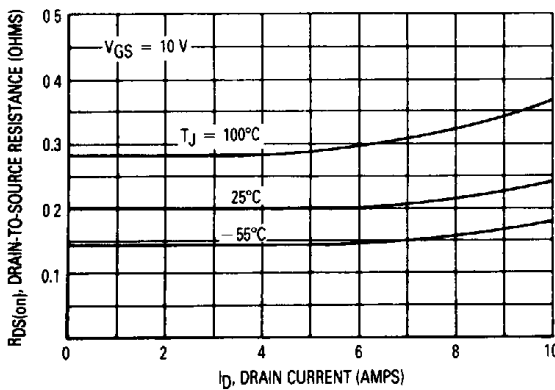

Figure 6. On-Resistance versus Drain Current

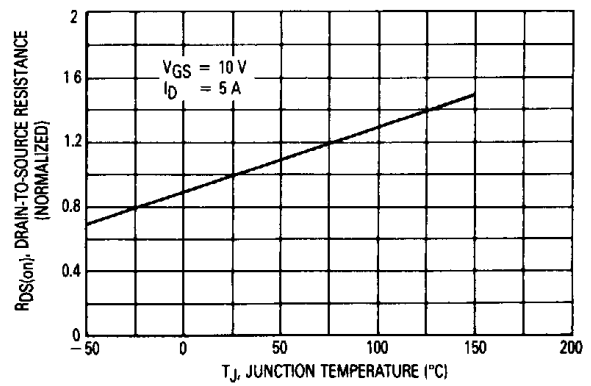

Figure 7. On-Resistance Variation With Temperature

MTD6N10

SAFE OPERATING AREA INFORMATION

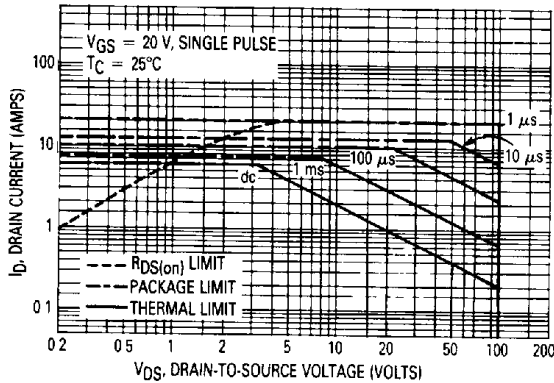

Figure 8. Maximum Rated Forward Biased Safe Operating Area

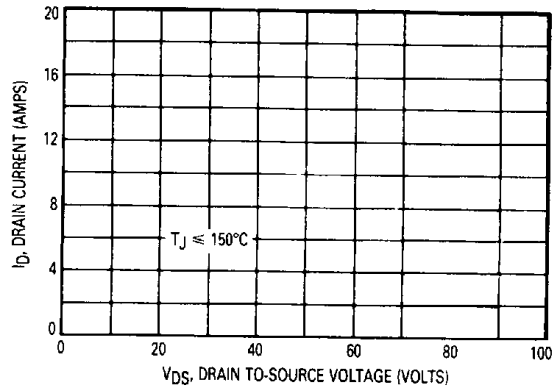

Figure 9. Maximum Rated Switching Safe Operating Area

FORWARD BIASED SAFE OPERATING AREA

The FBSOA curves define the maximum drain-to-source voltage and drain current that a device can safely handle when it is forward biased, or when it is on, or being turned on. Because these curves include the limitations of simultaneous high voltage and high current, up to the rating of the device, they are especially useful to designers of linear systems. The curves are based on a case temperature of 25°C and a maximum junction temperature of 150°C. Limitations for repetitive pulses at various case temperatures can be determined by using the thermal response curves. Motorola Application Note, AN569, "Transient Thermal Resistance-General Data and Its Use" provides detailed instructions.

SWITCHING SAFE OPERATING AREA

The switching safe operating area (SOA) of Figure 9 is the boundary that the load line may traverse without incurring damage to the MOSFET. The fundamental limits are the peak current, I_{DM} and the breakdown voltage, $V_{(BR)DSS}$. The switching SOA shown in Figure 9 is applicable for both turn-on and turn-off of the devices for switching times less than one microsecond.

The power averaged over a complete switching cycle must be less than:

$$\frac{T_{J(max)} - T_C}{R_{\theta JC}}$$

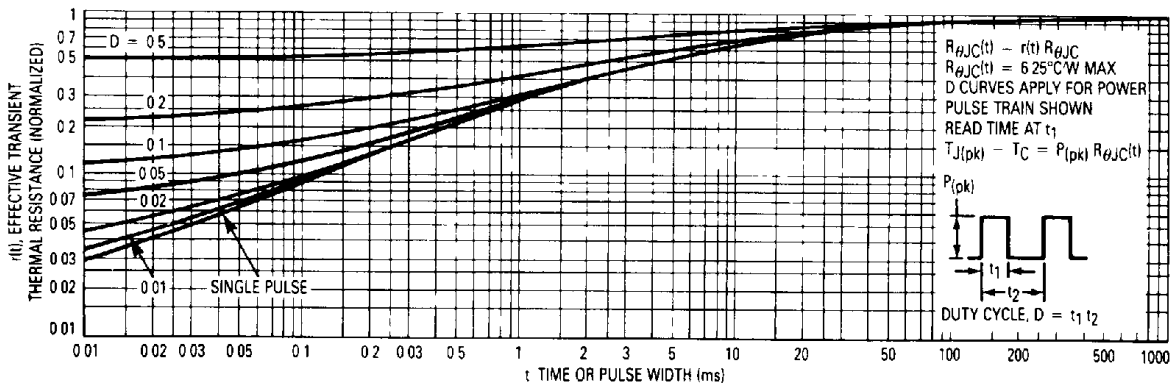

Figure 10. Thermal Response

MTD6N10

3

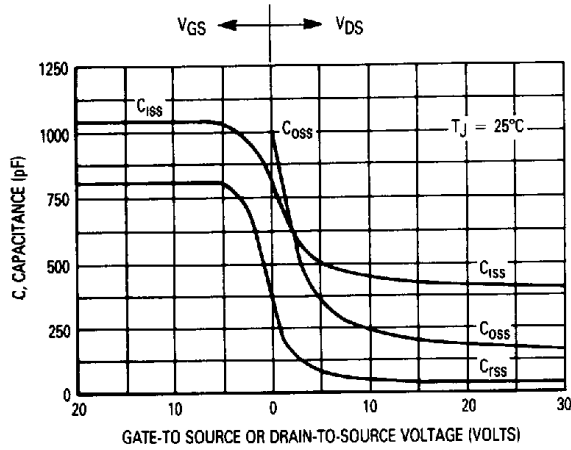

Figure 11. Capacitance Variation

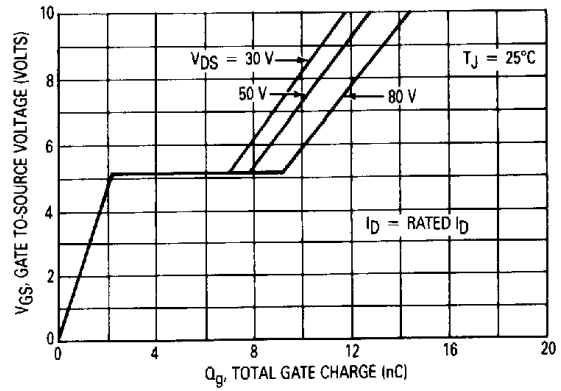

Figure 12. Gate Charge versus Gate-To-Source Voltage

RESISTIVE SWITCHING

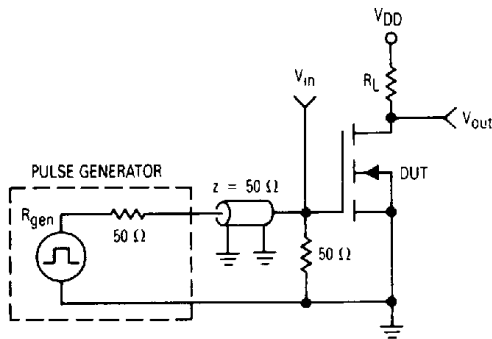

Figure 13. Switching Test Circuit

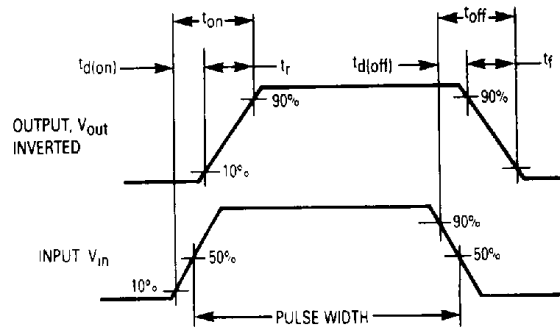

Figure 14. Switching Waveforms