

1. SCOPE

This specification is applied to the ceramics discriminator used with the type JTCV10.7MG3 for FM receiver. Please contact us before using any of the products in the applications not described above.

2. PART NO.:

PART NUMBER	CUSTOMER PART NO	SPECIFICATION NO
JTCV10.7MG3		

3. OUTLINE DRAWING:

Appearance: No visible damage and dirt.

Dimensions:

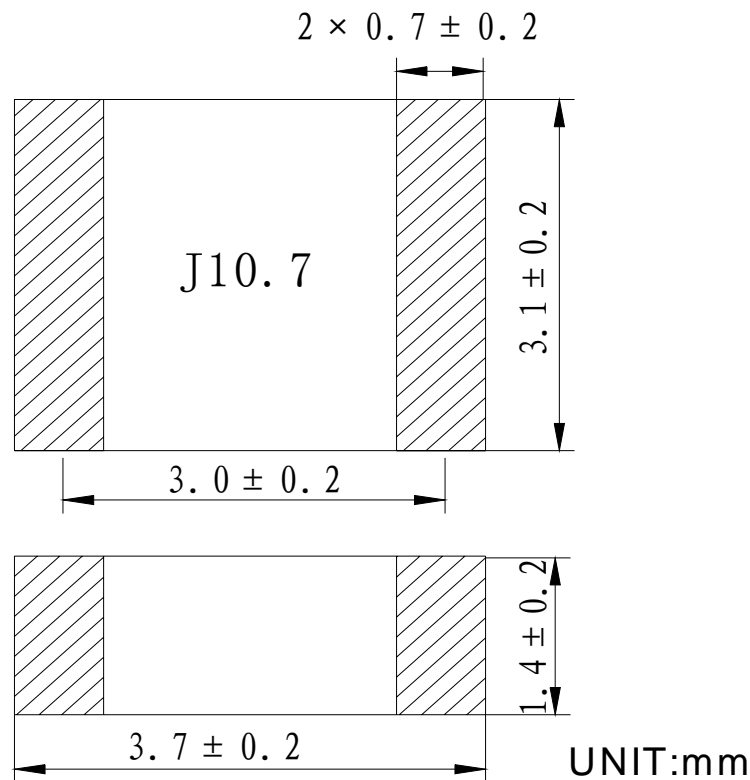

UNIT:mm

4. ELECTRICAL SPECIFICATIONS AND RATING

4.1 RATING

Items	Content
Temp. Coefficient of Frequency (ppm/°C) max	± 100
Insulation Resistance Ri,(MΩ) min	100
Withstanding Voltage (V)	50

4.2 ELECTRICAL SPECIFICATIONS

Items	Content
Center Frequency (fo)	A: 10.700MHz ± 30KHz (RED)
Recovered Audio Voltage (mV) min	650 (fo)
Distortion (%) max	1.0 (fo)
Recovered Audio 3dB Bandwidth (kHz) min	± 150

5 TEST

5.1 Test Conditions

Parts shall be measured under a condition (Temp. : 20±15 °C ,Humidity : 65±20% R.H.) unless the standard condition(Temp.: 25±2°C,Humidity : 65±5% R.H.) is regulated to measure.

5.2 Test Circuit:

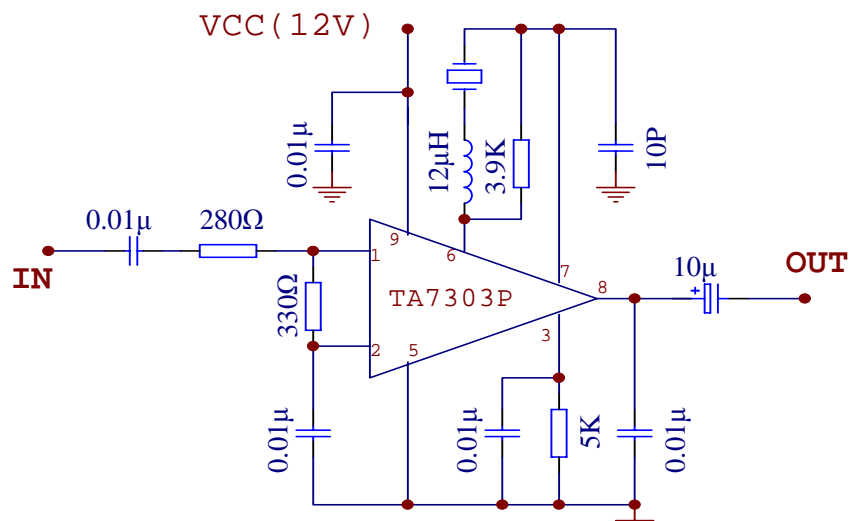

- 5.2.1 Input Signal: Input Level: 100dB μ V
 Modulation Frequency: 1000Hz
 Frequency Deviation: \pm 75kHz
- 5.2.2 Center Frequency (fo) : Center frequency is measured under the condition that modulated and 80dB μ V input signal (center) is supplied and varied its frequency. It is defined as the frequency at that D.C.output Voltage shall correspond to that for 0dB μ V input signal.
- 5.2.3 Recovered Audio Voltage: It is defined as the recovered audio voltage at center frequency (fo) .
- 5.2.4 Distortion: It is defined as the distortion at center frequency.
- 5.2.5 Recovered Audio 3dB Bandwidth: It is defined as the difference between the two frequencies where the recovered audio voltage 3dB from the level of center frequency.

6 PHYSICAL AND ENVIRONMENTAL CHARACTERISTICS

No	Item	Condition of Test	Performance Requirements
6.1	Humidity	Keep the discriminator at 40°C \pm 2°C and 90%~95% RH for 96h \pm 4h. Then release the discriminator into the room condition for 1h prior to the measurement.	It shall fulfill the specifications in Table 1.
6.2	High Temperature Exposure	Subject the discriminator to 80°C \pm 5°C for 96h \pm 4 h. Then release the discriminator into the room conditions for 1h prior to the measurement.	It shall fulfill the specifications in Table 1.
6.3	Low Temperature Exposure	Subject the discriminator to -20°C \pm 5°C for 96h \pm 4 h. Then release the discriminator into the room conditions for 1h prior to the measurement.	It shall fulfill the specifications in Table 1.
6.4	Temperature Cycling	Subject the discriminator to -40°C for 30 min. followed by a high temperature of 85°C for 30 min. cycling shall be repeated 5 times with a transfer time of 15 s. At the room temperature for 1h prior to the measurement.	It shall fulfill the specifications in Table 1.
6.5	Vibration	Subject the discriminator to vibration for 2 h each in x、 y and z axis with the amplitude of 1.5mm, the frequency shall be varied uniformly between the limits of 10 Hz.~55Hz.	It shall fulfill the specifications in Table 1.

Table Continue

6.6	Mechanical Shock	Drop the discriminator randomly onto a wooden floor from the height of 100cm 3 times.	No visible damage and it shall fulfill the specifications in Table 1.	
6.7	Resistance to Soldering Heat	Passed through the reflow oven under the following condition and left at room temperature for 1 hour before measurement.		It shall fulfill the specifications in Table 1.
		Temperature at the surface of the substrate	Time	
		Preheat 150°C±5°C	60s±10s	
		Peak 240°C±5°C	10s±3s	
6.8	Solderability	Dipped in 230°C±5°C solder bath for 3s±0.5 s with rosin flux (25wt%) ethanol solution.	More than 95% of the terminal surface of the discriminator shall be covered with fresh solder.	
6.9	Board Bending	<p>Mount a glass-epoxy board(width=40mm, thickness=1.6mm),then bend it to 1mm displacement and keepit for 5 s. (See the followingfigure)</p> 	Mechanical damage such as breaks shall not occur.	

TABLE 1 SPECIFICATION AFTER TEST ABOUT CHARACTERISTICS

Item	Specification after test
Center Frequency drift max.	± 30kHz
Recovered Audio Voltage drift max.	± 2dB
Note : The limits in the above table are referenced to the initial measurements.	

7 PACKAGE

To protect the products in storage and transportation, it is necessary to pack them (outer and inner package). On paper pack, the following requirements are requested.

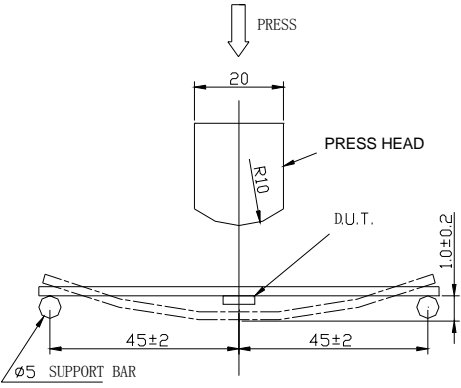
7.1 Dimensions and Mark

At the end of package, the warning (moisture proof, upward put) should be stick to it.

7.2 Dimensions and Mark (see below)

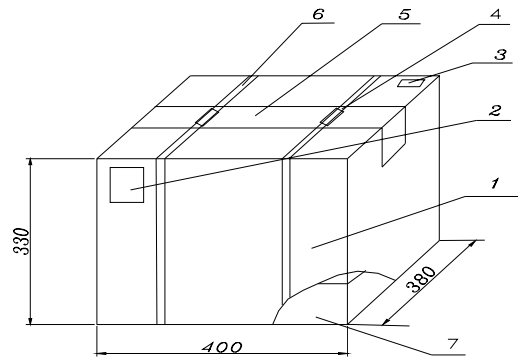

NO.	Name	Quantity	Notes
1	Package	1	
2	Certificate of approval	1	
3	Label	1	
4	Tying	2	
5	Adhesive tape	1.2m	
6	Belt	2.9m	
7	Inner Box	12	

7.3 Section of package

Package is made of corrugated paper with thickness of 0.8cm. Package has 12 inner boxes, each box has 1 reel (each reel for plastic bag)

7.4 Quantity of package

Per plastic reel 1000 pieces of piezoelectric ceramic part

Per inner box 5 reels

Per package 12 inner boxes

(60000 pieces of piezoelectric ceramic part

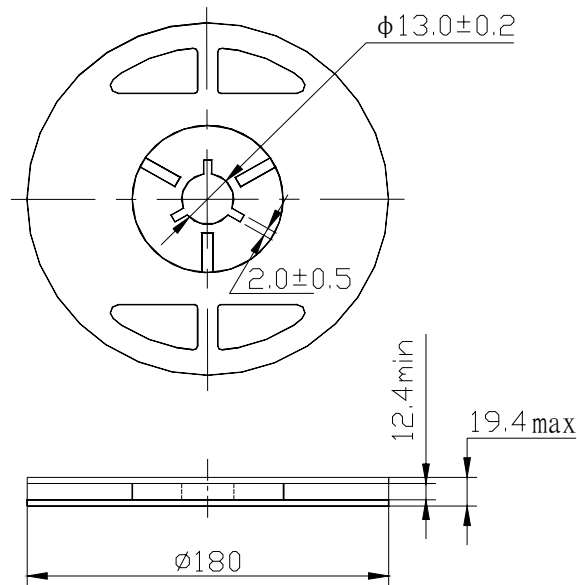
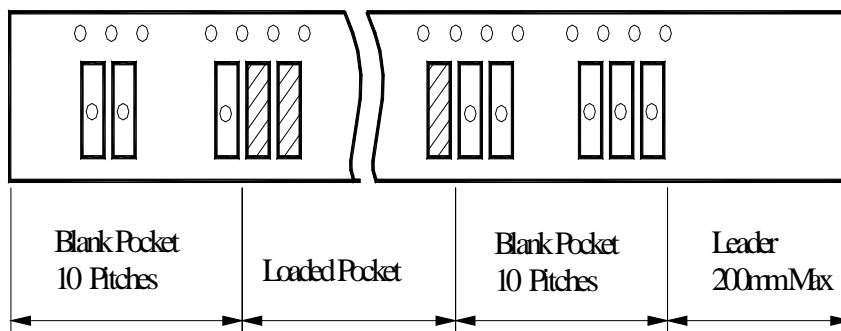
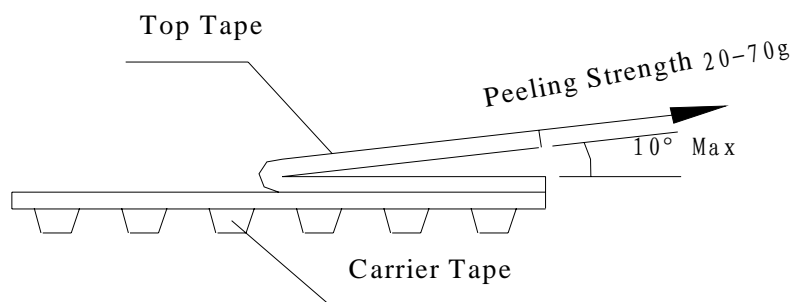
7.5 Reel

7.6.6 Packing Method Sketch Map

7.7 Test Condition Of Peeling Strength

8 OTHER

8.1 Caution of use

8.1.1 Do not use this product with bend. Please don't apply excess mechanical stress to the component and terminals at soldering.

8.1.2 The component may be damaged when an excess stress will be applied.

8.1.3 This specification mentions the quality of the component as a single unit. Please insure the component is thoroughly evaluated in your application circuit.

8.2 Notice

8.2.1 Please return one of this specification after your signature of acceptance.

8.2.2 When something gets doubtful with this specifications, we shall jointly work to get an agreement.