

MECHANICAL DATA

Dimensions in mm (inches)

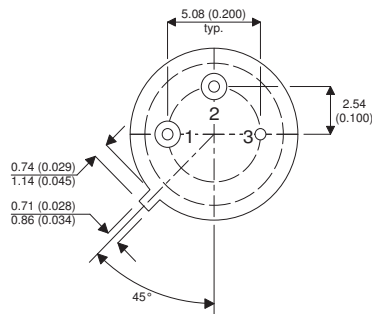
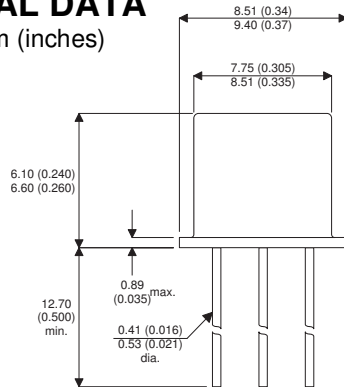

TO39 PACKAGE (TO205AD)

Pin 1 = Emitter Pin 2 = Base Pin 3 = Collector

NPN SILICON PLANER EPITAXIAL TRANSISTOR IN HERMETICALLY SEALED METAL CASE

APPLICATIONS

Intended for High Voltage, High Current Switching Applications up to 10A

ABSOLUTE MAXIMUM RATINGS

$T_{CASE} = 25^{\circ}C$ unless otherwise stated

V_{CBO}	Collector - Base Voltage	150V
V_{CEO}	Collector - Emitter Voltage ($I_B = 0$)	60V
V_{EBO}	Emitter - Base Voltage ($I_C = 0$)	7V
I_C	Continuous Collector Current	10A
I_B	Base Current	2A
P_{tot}	Total Power Dissipation at	$T_{case} = 25^{\circ}C$
		$T_{case} = 100^{\circ}C$
		$T_{amb} = 25^{\circ}C$
T_J	Junction Temperature	175°C
T_{stg}	Storage Temperature	-65 to +175°C

Semelab Plc reserves the right to change test conditions, parameter limits and package dimensions without notice. Information furnished by Semelab is believed to be both accurate and reliable at the time of going to press. However Semelab assumes no responsibility for any errors or omissions discovered in its use. Semelab encourages customers to verify that datasheets are current before placing orders.

THERMAL CHARACTERISTICS

		Max.	Unit
$R_{th\ j-case}$	Thermal resistance to case	5.0	°C/W
$R_{th\ j-amb}$	Thermal resistance junction to ambient	150	°C/W

ELECTRICAL CHARACTERISTICS ($T_{case} = -25^{\circ}C$ unless otherwise stated)

Parameter		Test Conditions		Min.	Typ.	Max.	Unit
h_{FE}^*	Forward-current transfer ratio	$I_C = 1.5A$	$V_{CE} = 5.0V$	40			
		$I_C = 10A$		15			
$V_{CE(sat)}^*$	Collector to Emitter Saturation Voltage	$I_C = 10A$	$I_B = 1A$			1.0	V
		$I_C = 1.5A$	$I_B = 150mA$			0.8	
$V_{BE(sat)}^*$	Base to Emitter Saturated Voltage	$I_C = 10A$	$I_B = 1A$			1.8	
		$I_C = 1.5A$	$I_B = 150mA$			1.2	
I_{CBO}	Collector to Base Cut-Off Current	$I_E = 0$	$V_{CB} = 100V$			10	μA
			$T_{Case} = 150^{\circ}C$			500	
I_{EBO}	Emitter to Base Cut-Off Current	$I_C = 0$	$V_{EB} = 5V$			10	

DYNAMIC CHARACTERISTICS

T_{on}	Turn-on time	$V_{CC} = 30V, I_C = 5.0A, I_B = 0.5A$			1.5	μs	
T_{off}	Turn-off time	$V_{CC} = 30V, I_C = 5.0A, I_{B1} = -I_{B2} = 0.5A$			1.5		
C_{ob}	Output Capacitance	$I_E = 0$ $f = 1.0MHz$	$V_{CB} = 10V$			200	μF
			$V_{EB} = 0.5V$			1200	
F_T	Transition Frequency	$I_C = 100mA$ $f = 20MHz$	$V_{CE} = 10V$	20		MHz	

* Pulse test $t_p = 300\mu s, \delta < 2\%$

Semelab Plc reserves the right to change test conditions, parameter limits and package dimensions without notice. Information furnished by Semelab is believed to be both accurate and reliable at the time of going to press. However Semelab assumes no responsibility for any errors or omissions discovered in its use. Semelab encourages customers to verify that datasheets are current before placing orders.