

700mA High PSRR, Low Noise, Fast Response Linear Regulator

DESCRIPTION

BL8068 series is a group of positive voltage output, low power consumption, low dropout voltage regulator.

BL8068 can provide output value in the range of 1.2V~4.5V every 0.1V step. It also can be customized on command.

BL8068 includes high accuracy voltage reference, error amplifier, current limit circuit and output driver module with discharge capability.

BL8068 has excellent load and line transient response and good temperature characteristics, which can assure the stability of chip and power system. And it uses trimming technique to guarantee output voltage accuracy within $\pm 2\%$.

BL8068 is available in SOT-23-5, SC-70-5 packages which is lead free.

FEATURES

- Low Power Consumption: 30uA (Typ.)
- Low output noise (50uVRMS)
- Standby Mode: 0.1uA
- Low dropout Voltage: 0.08V@150mA (Typ.)
- High Ripple Rejection: 72dB@1000Hz (Typ.)
- Low Temperature Coefficient: $\pm 100\text{ppm}/^\circ\text{C}$
- Excellent Line regulation: 0.05%/V
- Build-in chip enable and discharge circuit
- Output Voltage Range: 1.2V~4.5V (customized on command every 0.1V step)
- Highly Accurate: $\pm 2\%$
- Output Current Limit

APPLICATIONS

- Power source for cellular phones and various kind of PCSs
- Battery Powered equipment
- Power Management of MP3, PDA, DSC, Mouse, PS2 Games
- Reference Voltage Source
- Regulation after Switching Power

TYPICAL APPLICATION CIRCUIT

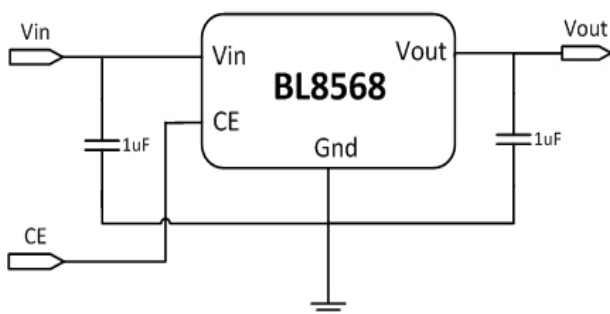

NOTE: Input capacitor ($C_{in}=1\mu\text{F}$) and Output capacitor ($C_{out}\geq 1\mu\text{F}$) are recommended in all application circuit.

ELECTRICAL CHARACTERISTICS

Load Regulation ($V_{in}=4.5\text{V}$, $V_{out}=3.3\text{V}$)

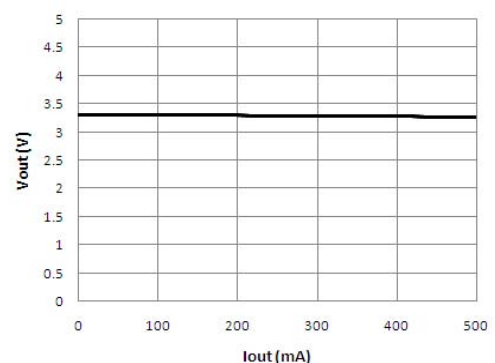

ORDERING INFORMATION

BL8068 ①②③④⑤

| Code | Description |
|------|--|
| ① | Temperature&Rohs: C: -40~85°C ,Pb Free Rohs Std. |
| ② | Package type: A5: SC-70-5 B5A: SOT-23-5(A) B5B: SOT-23-5(B) |
| ③ | Packing type: TR:Tape&Reel (Standard) |
| ④ | Output voltage: e.g. 15=1.5V 18=1.8V 45=4.5V |
| ⑤ | Voltage accuracy: Blank(default)=±2% |

MARKING DESCRIPTION

F̄: Product Code

X: Output Voltage

| Vout | Code | Vout | Code | Vout | Code |
|------|----------|------|----------|------|----------|
| | | 2.6V | <u>6</u> | 4.1V | <u>1</u> |
| 1.2V | 2 | 2.7V | <u>7</u> | 4.2V | <u>2</u> |
| 1.3V | 3 | 2.8V | <u>8</u> | 4.3V | <u>3</u> |
| 1.4V | 4 | 2.9V | <u>9</u> | 4.4V | <u>4</u> |
| 1.5V | 5 | 3.0V | <u>0</u> | 4.5V | <u>5</u> |
| 1.6V | 6 | 3.1V | <u>1</u> | | |
| 1.7V | 7 | 3.2V | <u>2</u> | | |
| 1.8V | 8 | 3.3V | <u>3</u> | | |
| 1.9V | 9 | 3.4V | <u>4</u> | | |
| 2.0V | <u>0</u> | 3.5V | <u>5</u> | | |
| 2.1V | <u>1</u> | 3.6V | <u>6</u> | | |
| 2.2V | <u>2</u> | 3.7V | <u>7</u> | | |
| 2.3V | <u>3</u> | 3.8V | <u>8</u> | | |
| 2.4V | <u>4</u> | 3.9V | <u>9</u> | | |
| 2.5V | <u>5</u> | 4.0V | <u>0</u> | | |

Date code 1st Z: The year of manufacturing, "8" for year 2008, and "0" for year 2010.

Date code 2nd Z: The week of manufacturing, "A" for week 1, "Z" for week 26, "A" for week 27, "Z" for week 52.

PIN CONFIGURATION

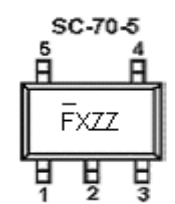
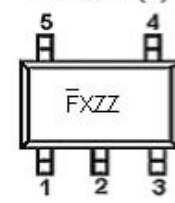
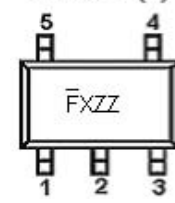
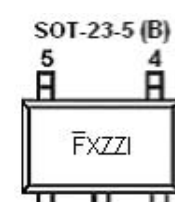
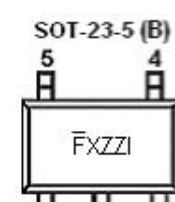
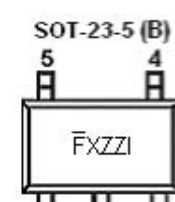
| | | | |
|----------|-------------------|---|--|
| Part No. | | BL8068CA5TR□□□ | |
| Marking | |  | |
| F̄XZZ | F: product code |  | 1 Vin 2 Vss 3 CE 4 NC 5 Vout |
| | X: output voltage | | |
| | ZZ: date code | | |
| Part No. | | BL8068CB5ATR□□□ | |
| Marking | |  | |
| F̄XZZ | F: product code |  | 1 Vin 2 Vss 3 CE 4 NC 5 Vout |
| | X: output voltage | | |
| | ZZ: date code | | |
| Part No. | | BL8068CB5BTR□□□ | |
| Marking | |  | |
| F̄XZZI | F: product code |  | 1 Vout 2 Vss 3 Vin 4 CE 5 NC |
| | X: output voltage | | |
| | ZZ: date code | | |
| | | : Type B | |

PIN DESCRIPTION

| Pin | Description |
|------|----------------------|
| Vss | Ground |
| Vin | Input voltage supply |
| Vout | Output voltage |
| CE | Chip enable |
| NC | No connection |

BLOCK DIAGRAM

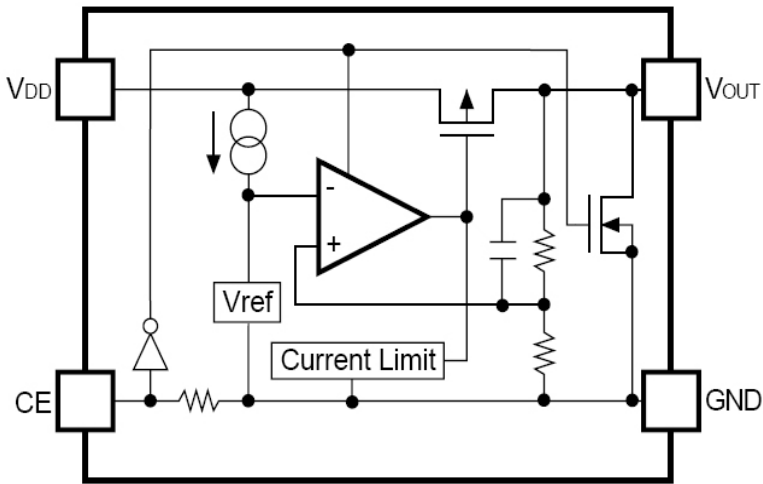

DIAGRAM EXPLANATION

BL8068 includes high accuracy voltage reference, error amplifier, current limit circuit and output driver module with discharge capability.

BL8068 has excellent load and line transient response and good temperature characteristics, which can assure the stability of chip and power system. And it uses trimming technique to guarantee output voltage accuracy within $\pm 2\%$.

Low ESR ceramic capacitor can be used for BL8068 for both input and output ends. Both 1 μ F can keep BL8068 work stable. However, a larger output capacitor, such as 3.3 μ F /4.7 μ F is always recommended to compensate dynamic load current change.

ABSOLUTE MAXIMUM RATING

| Parameters | | Value |
|-------------------------------------|---------|--------------|
| Input Voltage | | -0.3 ~ 6 V |
| Operation Junction Temperature (Tj) | | 150 °C |
| Output Current | | 800 mA |
| Storage Temperature | | -65 ~ 150 °C |
| Power Dissipation | SC70-5 | 250 mW |
| | SOT23-5 | 360 mW |
| IR Reflow Lead Temperature and Time | | 260°C , 10s |
| ESD Rating, Human Body Mode | | 3000 V |

Note:

Exceed these limits to damage to the device.

Exposure to absolute maximum rating conditions may affect device reliability.

RECOMMENDED OPERATION RANGE

| Parameters | Value |
|-------------------------------|-------------|
| Input Voltage | 1.2 ~ 6 V |
| Operation Ambient Temperature | -40 ~ 85 °C |

ELECTRICAL CHARACTERISTICS

Test condition: $C_{in}=1\mu F$, $C_{out}=1\mu F$, $T_A=25^\circ C$, unless otherwise specified.

BL8068, for arbitrary output voltage (V_{out_set})

| Symbol | Parameters | Condition | Min. | Typ. | Max. | Unit |
|--|--|---|---------------------------------|----------------|---------------------------------|-----------------|
| V_{in} | Input Voltage | | 1.2 | | 6 | V |
| V_{out} | Output Voltage | $V_{in}=V_{out_set}+1V$ $1mA \leq I_{out} \leq 30mA$ | V_{out_set} $\times 0.98$ | V_{out_set} | V_{out_set} $\times 1.02$ | V |
| I_{out_MAX} | Maximum Output Current | | 700 | | | mA |
| V_{drop} | Dropout Voltage, $V_{out} \geq 2.8V$ | $I_{out}=50mA$ | | 25 | 40 | mV |
| | | $I_{out}=100mA$ | | 50 | 75 | mV |
| | | $I_{out}=150mA$ | | 75 | 115 | mV |
| | | $I_{out}=400mA$ | | 220 | 280 | mV |
| $\frac{\Delta V_{out}}{\Delta V_{in} \cdot V_{out}}$ | Line Regulation | $I_{out}=40mA$; $2.8V \leq V_{in} \leq 6V$ | | 0.05 | 0.1 | %/V |
| $\Delta V_{out} / \Delta I_{out}$ | Load Regulation | $V_{in}=V_{out_set}+1V$ $1mA \leq I_{out} \leq 500mA$ | | 100 | 150 | mV |
| I_{ss} | Supply Current when Operation | $V_{in}=V_{out_set}+1V$ | | 30 | 50 | μA |
| $I_{shutdown}$ | Supply Current when Shut Down | $V_{in}=V_{out_set}+1V$, $V_{ce}=0V$ | | 0.1 | 1 | μA |
| $\frac{\Delta V_{out}}{\Delta T \cdot V_{out}}$ | Output Voltage Temperature Coefficient | $V_{in}=Set$ $V_{out}+1V$ $I_{out}=30mA$ | | ± 50 | | ppm/ $^\circ C$ |
| PSRR | Power Supply Ripple Rejection Rate | $F=1000Hz$, $Ripple=0.5V_{pp}$ $V_{in}=V_{out_set}+1V$ | | 72 | | dB |
| I_{limit} | Output Short Current Limit | $V_{out}=0V$ | | 800 | | mA |
| V_{ceh} | CE Input Voltage for "High" | | 1.4 | | | V |
| V_{cel} | CE Input Voltage for "Low" | | | | 0.25 | V |
| e_n | Output Noise | Bandwidth=10~100KHz | | 50 | | μV_{rms} |

NOTE:

V_{out_set} is the nominal output voltage that BL8068 is set to, for example 3.3V.

$V_{drop}=V_{in}-(V_{out} \times 0.98)$, in which V_{out} is the output voltage when $V_{in}=V_{out_set}+1.0V$ at different output current, and V_{in} is the input voltage at which the output voltage becomes 98% of V_{out} after gradually decreasing the input voltage.

TYPICAL PERFORMANCE CHARACTERISTICS (Cont')

Test condition: $C_{in}=1\mu F$, $C_{out}=1\mu F$, $T_A=25^\circ C$, CE pin is tied to V_{in} , $V_{out_set}=3.3V$, unless otherwise specified.

5) Line Transient Response (Ch1: V_{in} 4↔5V; Ch2: V_{out})

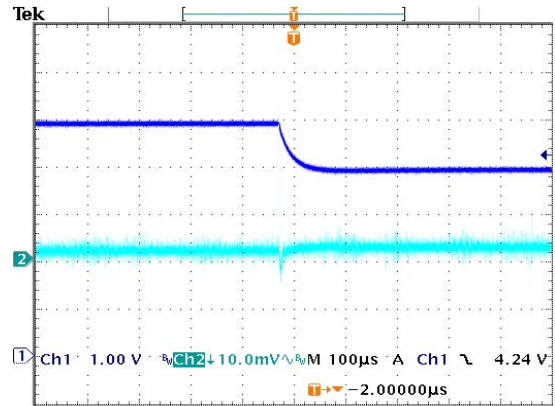
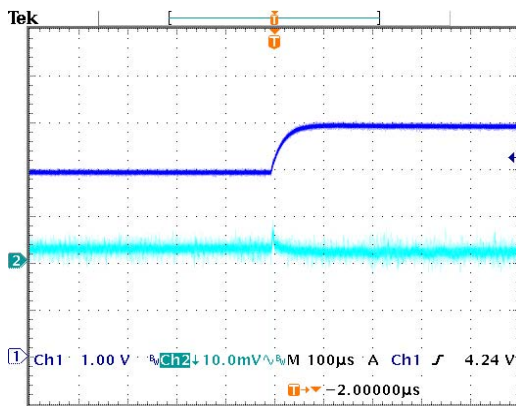

6) Load Transient Response (Ch1: I_{out} 1↔50mA; Ch2: V_{out})

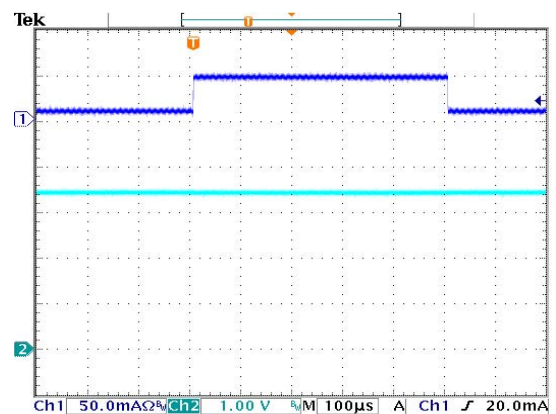
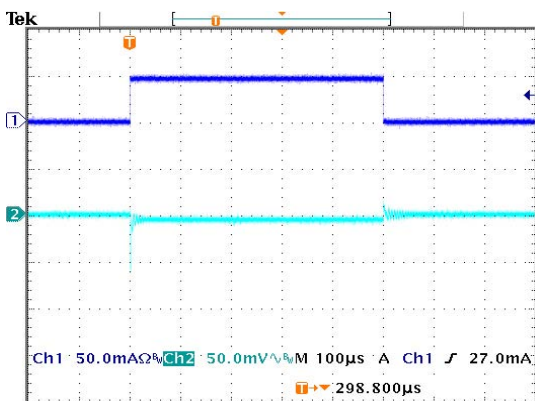

7) Startup by CE (Ch1: V_{out} ; Ch2: CE)

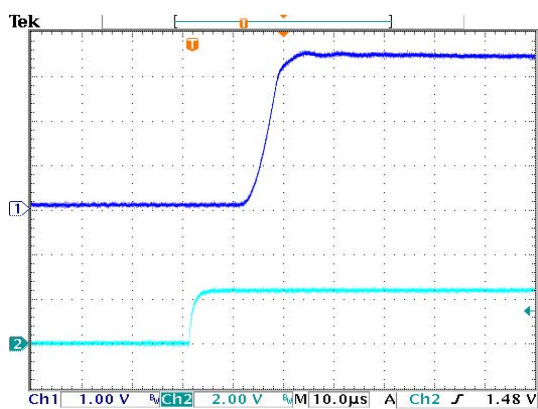

8) Shutdown by CE (Ch1: V_{out} ; Ch2: CE)

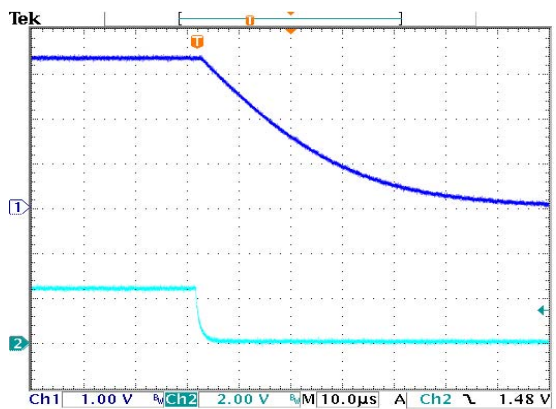

PACKAGE OUTLINE DIMENSION

| | |
|------------------|--------|
| Package | SC70-5 |
| Devices per reel | 3000 |

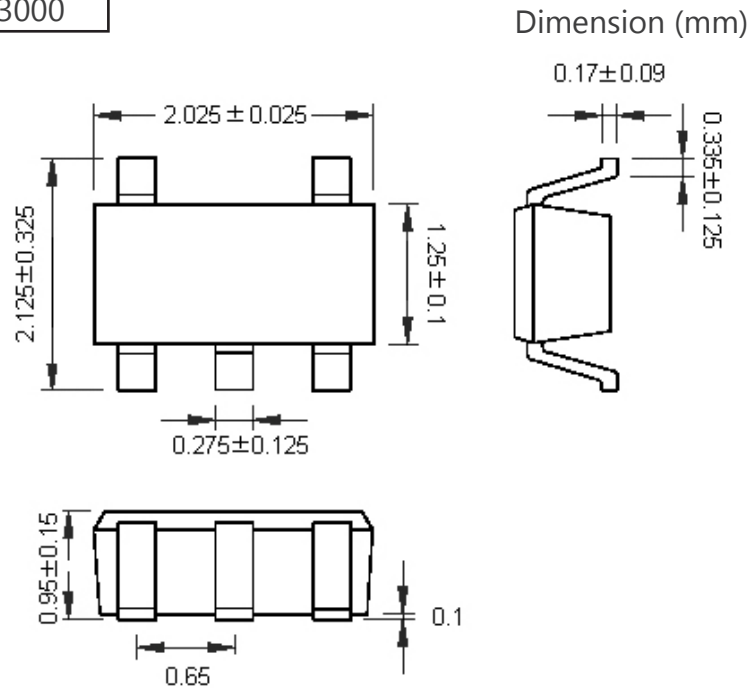

| | |
|------------------|---------|
| Package | SOT23-5 |
| Devices per reel | 3000 |

