

General Description

The ICS843001I-23 is a highly versatile, low phase noise LVPECL/LVCMOS Synthesizer which can generate low jitter reference clocks for a variety of communication applications. The dual crystal interface allows the synthesizer to support up to three communication standards in a given application (i.e. SONET with a 19.44MHz crystal, 1Gb/10Gb Ethernet and Fibre Channel using a 25MHz crystal). The RMS phase jitter performance is typically less than 1ps, thus making the device acceptable for use in demanding applications such as OC48 SONET, GbE/10Gb Ethernet and SAN applications. The ICS843001I-23 is packaged in a small 24-pin TSSOP, E-Pad package.

Features

- One 3.3V differential LVPECL output pair and one LVCMOS/LVTTL single-ended reference clock output
- Selectable crystal oscillator interface or LVCMOS/LVTTL single-ended input
- Crystal and CLK range: 19.44MHz – 27MHz
- Able to generate GbE/10GbE/12GbE, Fibre Channel (1Gb/4Gb/10Gb), PCI-E and SATA from a 25MHz crystal
- VCO range: 1.12GHz – 1.275GHz
- Supports the following applications: SONET, Ethernet, Fibre Channel, Serial ATA, and HDTV
- RMS phase jitter @ 622.08MHz (12kHz - 20MHz): 0.9ps (typical), 3.3V
- Supply modes
 V_{CC}/V_{CCO}
 3.3V/3.3V
 3.3V/2.5V
 2.5V/2.5V
- -40°C to 85°C ambient operating temperature
- Available in both standard (RoHS 5) and lead-free (RoHS 6) package

Block Diagram

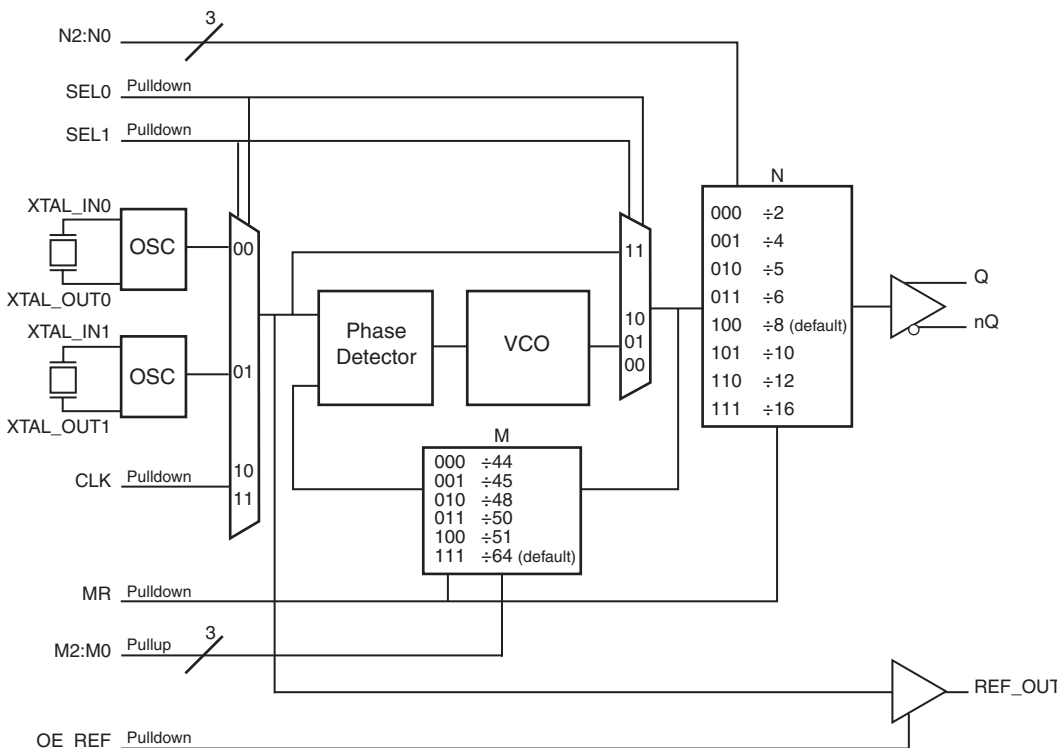

Pin Assignment

V_{CCO_LVCMOS}	1	24	REF_OUT
N0	2	23	VEE
N1	3	22	OE_REF
N2	4	21	M2
V_{CCO_LVPECL}	5	20	M1
Q	6	19	M0
nQ	7	18	MR
VEE	8	17	SEL1
VCCA	9	16	SEL0
VCC	10	15	CLK
XTAL_OUT1	11	14	XTAL_IN0
XTAL_IN1	12	13	XTAL_OUT0

ICS843001I-23

24-Lead TSSOP, E-Pad
4.4mm x 7.8mm x 0.925mm
package body
G Package
Top View

Table 1. Pin Descriptions

Number	Name	Type		Description
1	V _{CCO_LVCMOS}	Power		Output supply pin for REF_CLK output.
2, 3	N0, N1	Input	Pulldown	Output divider select pins. LVCMOS/LVTTL interface levels. See Table 3C.
4	N2	Input	Pullup	
5	V _{CCO_LVPECL}	Power		Output supply pin for LVPECL output.
6, 7	Q, nQ	Output		Differential output pair. LVPECL interface levels.
8, 23	V _{EE}	Power		Negative supply pins.
9	V _{CCA}	Power		Analog supply pin.
10	V _{CC}	Power		Core supply pin.
11, 12	XTAL_OUT1, XTAL_IN1	Input		Parallel resonant crystal interface. XTAL_OUT1 is the output, XTAL_IN1 is the input.
13, 14	XTAL_OUT0, XTAL_IN0	Input		Parallel resonant crystal interface. XTAL_OUT0 is the output, XTAL_IN0 is the input.
15	CLK	Input	Pulldown	Single-ended clock input. LVCMOS/LVTTL interface levels.
16, 17	SEL0, SEL1	Input	Pulldown	Input MUX select pins. LVCMOS/LVTTL interface levels. See Table 3D.
18	MR	Input	Pulldown	Active HIGH Master Reset. When logic HIGH, the internal dividers are reset causing the true output Q to go low and the inverted output nQ to go high. When logic LOW, the internal dividers and the outputs are enabled. LVCMOS/LVTTL interface levels.
19, 20, 21	M0, M1, M2	Input	Pullup	Feedback divider select pins. LVCMOS/LVTTL interface levels. See Table 3B.
22	OE_REF	Input	Pulldown	Reference clock output enable. Default LOW. See Table 3E. LVCMOS/LVTTL interface levels.
24	REF_OUT	Output		Reference clock output. LVCMOS/LVTTL interface levels.

NOTE: *Pullup* and *Pulldown* refer to internal input resistors. See Table 2, *Pin Characteristics*, for typical values.

Table 2. Pin Characteristics

Symbol	Parameter	Test Conditions	Minimum	Typical	Maximum	Units
C _{IN}	Input Capacitance			4		pF
R _{PULLUP}	Input Pullup Resistor			51		kΩ
R _{PULLDOWN}	Input Pulldown Resistor			51		kΩ
R _{OUT}	Output Impedance	REF_OUT	V _{CCO} = 3.3V	21		Ω
			V _{CCO} = 2.5V	25		Ω

Function Tables

Table 3A. Common Configuration Table

Input Frequency (MHz)	M Feedback Divider Value	VCO Frequency (MHz)	N Output Divider Value	Output Frequency (MHz)	Application
27	44	1188	16	74.25	HDTV
24.75	48	1188	16	74.25	HDTV
19.44	64	1244.16	8	155.52	SONET
19.44	64	1244.16	2	622.08	SONET
19.44	64	1244.16	4	311.04	SONET
25	50	1250	10	125	GigE
25	50	1250	8	156.25	10 GigE
25	50	1250	5	250	GigE
25	50	1250	4	312.5	XGMII
25	50	1250	2	625	10 GigE
25	45	1125	6	187.5	12 GigE
25	48	1200	12	100	PCI Express
25	48	1200	8	150	SATA
25	48	1200	16	75	SATA
25	51	1275	12	106.25	Fibre Channel
25	51	1275	8	159.375	10 Gig Fibre Channel
25	51	1275	6	212.5	4 Gig Fibre Channel

Table 3B. Programmable M Feedback Divider Function Table

Inputs			M Feedback Divider Value	Input Frequency (MHz)	
M2	M1	M0		Minimum	Maximum
0	0	0	44	25.5	27
0	0	1	45	24.9	27
0	1	0	48	23.3	26.56
0	1	1	50	22.4	25.5
1	0	0	51	22.0	25
1	0	1	64 (default)	19.44	19.92

Table 3C. Programmable N Output Divider Function Table

Inputs			N Divider Value
N2	N1	N0	
0	0	0	2
0	0	1	4
0	1	0	5
0	1	1	6
1	0	0	8 (default)
1	0	1	10
1	1	0	12
1	1	1	16

Table 3D. Select Mode Function Table

Inputs		Reference Input	PLL Mode
SEL1	SEL0		
0	0	XTAL0	Active (default)
0	1	XTAL1	Active
1	0	CLK	Active
1	1	CLK	Bypass

Table 3E. OE_REF Output Function Table

Input	Output
OE_REF	REF_OUT
0	High-Impedance (default)
1	Active

Absolute Maximum Ratings

NOTE: Stresses beyond those listed under *Absolute Maximum Ratings* may cause permanent damage to the device. These ratings are stress specifications only. Functional operation of product at these conditions or any conditions beyond those listed in the *DC Characteristics* or *AC Characteristics* is not implied. Exposure to absolute maximum rating conditions for extended periods may affect product reliability.

Item	Rating
Supply Voltage, V_{CC}	4.6V
Inputs, V_I XTAL_IN Other Input	0V to V_{CC} -0.5V to $V_{CC} + 0.5V$
Outputs, I_O (LVPECL) Continuous Current Surge Current	50mA 100mA
Outputs, V_O (LVCMOS)	-0.5V to $V_{CCO_LVCMOS} + 0.5V$
Package Thermal Impedance, θ_{JA}	32.1°C/W (0 mps)
Storage Temperature, T_{STG}	-65°C to 150°C

DC Electrical Characteristics

Table 4A. Power Supply DC Characteristics, $V_{CC} = V_{CCO_LVCMOS} = V_{CCO_LVPECL} = 3.3V \pm 5\%$, $V_{EE} = 0V$, $T_A = -40^\circ C$ to $85^\circ C$

Symbol	Parameter	Test Conditions	Minimum	Typical	Maximum	Units
V_{CC}	Core Supply Voltage		3.135	3.3	3.465	V
V_{CCA}	Analog Supply Voltage		$V_{CC} - 0.11$	3.3	V_{CC}	V
V_{CCO_LVPECL} , V_{CCO_LVCMOS}	Output Supply Voltage		3.135	3.3	3.465	V
I_{EE}	Power Supply Current				140	mA
I_{CCA}	Analog Supply Current	Outputs Unterminated			11	mA

Table 4B. Power Supply DC Characteristics, $V_{CC} = 3.3V \pm 5\%$, $V_{CCO_LVCMOS} = V_{CCO_LVPECL} = 2.5V \pm 5\%$, $V_{EE} = 0V$, $T_A = -40^\circ C$ to $85^\circ C$

Symbol	Parameter	Test Conditions	Minimum	Typical	Maximum	Units
V_{CC}	Core Supply Voltage		3.135	3.3	3.465	V
V_{CCA}	Analog Supply Voltage		$V_{CC} - 0.11$	3.3	V_{CC}	V
V_{CCO_LVPECL} , V_{CCO_LVCMOS}	Output Supply Voltage		2.375	2.5	2.625	V
I_{EE}	Power Supply Current				139	mA
I_{CCA}	Analog Supply Current	Outputs Unterminated			11	mA

Table 4C. Power Supply DC Characteristics, $V_{CC} = V_{CCO_LVCMOS} = V_{CCO_LVPECL} = 2.5V \pm 5\%$, $V_{EE} = 0V$, $T_A = -40^\circ C$ to $85^\circ C$

Symbol	Parameter	Test Conditions	Minimum	Typical	Maximum	Units
V_{CC}	Core Supply Voltage		2.375	2.5	2.625	V
V_{CCA}	Analog Supply Voltage		$V_{CC} - 0.10$	2.5	V_{CC}	V
V_{CCO_PECL} , V_{CCO_CMOS}	Output Supply Voltage		2.375	2.5	2.625	V
I_{EE}	Power Supply Current				133	mA
I_{CCA}	Analog Supply Current	Outputs Unterminated			10	mA

Table 4D. LVCMOS/LVTTL DC Characteristics, $T_A = -40^\circ C$ to $85^\circ C$

Symbol	Parameter	Test Conditions	Minimum	Typical	Maximum	Units
V_{IH}	Input High Voltage	$V_{CC} = 3.3V$	2		$V_{CC} + 0.3$	V
		$V_{CC} = 2.5V$	1.7		$V_{CC} + 0.3$	V
V_{IL}	Input Low Voltage	$V_{CC} = 3.3V$	-0.3		0.8	V
		$V_{CC} = 2.5V$	-0.3		0.7	V
I_{IH}	Input High Current	CLK, OE_REF, MR, N0, N1 SEL0, SEL1 $V_{CC} = V_{IN} = 3.465V$ or $2.625V$			150	μA
		N2, M[2:0] $V_{CC} = V_{IN} = 3.465V$ or $2.625V$			5	μA
I_{IL}	Input Low Current	CLK, OE_REF, MR, N0, N1 SEL0, SEL1 $V_{CC} = 3.465V$ or $2.625V$, $V_{IN} = 0V$	-5			μA
		N2, M[2:0] $V_{CC} = 3.465V$ or $2.625V$, $V_{IN} = 0V$	-150			μA
V_{OH}	Output High Voltage	REF_OUT $V_{CCO_LVCMOS} = 3.465V$, $I_{OH} = -12mA$	2.6			V
		$V_{CCO_LVCMOS} = 2.625V$, $I_{OH} = -12mA$	1.8			V
V_{OL}	Output Low Voltage	REF_OUT $V_{CCO_LVCMOS} = 3.465V$ or $2.625V$, $I_{OL} = 12mA$			0.5	V

Table 4E. LVPECL DC Characteristics, $V_{CC} = V_{CCO_LVPECL} = 3.3V \pm 5\%$, $V_{EE} = 0V$, $T_A = -40^\circ C$ to $85^\circ C$

Symbol	Parameter	Test Conditions	Minimum	Typical	Maximum	Units
V_{OH}	Output High Voltage; NOTE 1		$V_{CCO_LVPECL} - 1.4$		$V_{CCO_LVPECL} - 0.9$	V
V_{OL}	Output Low Voltage; NOTE 1		$V_{CCO_LVPECL} - 2.0$		$V_{CCO_LVPECL} - 1.7$	V
V_{SWING}	Peak-to-Peak Output Voltage Swing		0.6		1.0	V

NOTE 1: Outputs terminated with 50Ω to $V_{CCO_LVPECL} - 2V$.

Table 4F. LVPECL DC Characteristics, $V_{CC} = 3.3V \pm 5\%$ or $2.5V \pm 5\%$, $V_{CCO_LVPECL} = 2.5V \pm 5\%$, $V_{EE} = 0V$, $T_A = -40^\circ C$ to $85^\circ C$

Symbol	Parameter	Test Conditions	Minimum	Typical	Maximum	Units
V_{OH}	Output High Voltage; NOTE 1		$V_{CCO_LVPECL} - 1.4$		$V_{CCO_LVPECL} - 0.9$	V
V_{OL}	Output Low Voltage; NOTE 1		$V_{CCO_LVPECL} - 2.0$		$V_{CCO_LVPECL} - 1.5$	V
V_{SWING}	Peak-to-Peak Output Voltage Swing		0.4		1.0	V

NOTE 1: Outputs terminated with 50Ω to $V_{CCO_LVPECL} - 2V$.**Table 5. Crystal Characteristics**

Parameter	Test Conditions	Minimum	Typical	Maximum	Units
Mode of Oscillation		Fundamental			
Frequency		19.44		27	MHz
Equivalent Series Resistance (ESR)				50	Ω
Shunt Capacitance				7	pF

NOTE: Characterized using an 18pF parallel resonant crystal.

AC Electrical Characteristics

Table 6A. AC Characteristics, $V_{CC} = V_{CCO_LVCMOS} = V_{CCO_LVPECL} = 3.3V \pm 5\%$, $V_{EE} = 0V$, $T_A = -40^\circ C$ to $85^\circ C$

Symbol	Parameter	Test Conditions	Minimum	Typical	Maximum	Units	
f_{OUT}	Output Frequency	Q, nQ	70		637.5	MHz	
		REF_OUT	19.44		27	MHz	
t_{PD}	Propagation Delay; NOTE 1	CLK to REF_OUT	2.2		2.7	ns	
$f_{jit}(\emptyset)$	RMS Phase Jitter, (Random); NOTE 2	622.08MHz, (12kHz – 20MHz)		0.97		ps	
f_{VCO}	PLL VCO Lock Range		1.12		1.275	GHz	
t_R / t_F	Output Rise/Fall Time	Q, nQ	20% to 80%	200		700	ps
		REF_OUT, NOTE 3	20% to 80%	250		650	ps
odc	Output Duty Cycle	Q, nQ		46		54	%
		REF_OUT; NOTE 3	Using Clock Input	48		52	%
t_{LOCK}	PLL Lock Time				60	ms	

NOTE: Electrical parameters are guaranteed over the specified ambient operating temperature range, which is established when the device is mounted in a test socket with maintained transverse airflow greater than 500 lpm. The device will meet specifications after thermal equilibrium has been reached under these conditions.

NOTE 1: Measured from the $V_{CC}/2$ of the input to $V_{CCO_LVCMOS}/2$ of the output.

NOTE 2: Phase jitter measured using a 19.44MHz quartz crystal.

NOTE 3: REF_OUT output duty cycle characterized with CLK input duty cycle between 48% and 52%.

Table 6B. AC Characteristics, $V_{CC} = 3.3V \pm 5\%$, $V_{CCO_LVCMOS} = V_{CCO_LVPECL} = 2.5V \pm 5\%$, $V_{EE} = 0V$, $T_A = -40^\circ C$ to $85^\circ C$

Symbol	Parameter	Test Conditions	Minimum	Typical	Maximum	Units
f_{OUT}	Output Frequency	Q, nQ	70		637.5	MHz
		REF_OUT	19.44		27	MHz
t_{PD}	Propagation Delay; NOTE 1	CLK to REF_OUT	2.3		2.9	ns
$f_{jit}(\emptyset)$	RMS Phase Jitter, (Random); NOTE 2	622.08MHz, (12kHz – 20MHz)		1		ps
f_{VCO}	PLL VCO Lock Range		1.12		1.275	GHz
t_R / t_F	Output Rise/Fall Time	Q, nQ	20% to 80%	200	700	ps
		REF_OUT	20% to 80%	350	750	ps
odc	Output Duty Cycle	Q, nQ		46	54	%
		REF_OUT; NOTE 3	Using Clock Input	48	52	%
t_{LOCK}	PLL Lock Time				60	ms

NOTE: Electrical parameters are guaranteed over the specified ambient operating temperature range, which is established when the device is mounted in a test socket with maintained transverse airflow greater than 500 lfm. The device will meet specifications after thermal equilibrium has been reached under these conditions.

NOTE 1: Measured from the $V_{CC}/2$ of the input to $V_{CCO_LVCMOS}/2$ of the output.

NOTE 2: Phase jitter measured using a 19.44MHz quartz crystal.

NOTE 3: REF_OUT output duty cycle characterized with CLK input duty cycle between 48% and 52%.

Table 6C. AC Characteristics, $V_{CC} = V_{CCO_LVCMOS} = V_{CCO_LVPECL} = 2.5V \pm 5\%$, $V_{EE} = 0V$, $T_A = -40^\circ C$ to $85^\circ C$

Symbol	Parameter	Test Conditions	Minimum	Typical	Maximum	Units
f_{OUT}	Output Frequency	Q, nQ	70		637.5	MHz
		REF_OUT	19.44		27	MHz
t_{PD}	Propagation Delay; NOTE 1	CLK to REF_OUT	2.3		2.9	ns
$f_{jit}(\emptyset)$	RMS Phase Jitter, (Random); NOTE 2	622.08MHz, (12kHz – 20MHz)		1.1		ps
f_{VCO}	PLL VCO Lock Range		1.12		1.275	GHz
t_R / t_F	Output Rise/Fall Time	Q, nQ	20% to 80%	200	700	ps
		REF_OUT	20% to 80%	350	750	ps
odc	Output Duty Cycle	Q, nQ		46	54	%
		REF_OUT; NOTE 3	Using Clock Input	48	52	%
t_{LOCK}	PLL Lock Time				60	ms

NOTE: Electrical parameters are guaranteed over the specified ambient operating temperature range, which is established when the device is mounted in a test socket with maintained transverse airflow greater than 500 lfm. The device will meet specifications after thermal equilibrium has been reached under these conditions.

NOTE 1: Measured from the $V_{CC}/2$ of the input to $V_{CCO_LVCMOS}/2$ of the output.

NOTE 2: Phase jitter measured using a 19.44MHz quartz crystal.

NOTE 3: REF_OUT output duty cycle characterized with CLK input duty cycle between 48% and 52%.

Typical Phase Noise at 622.08MHz

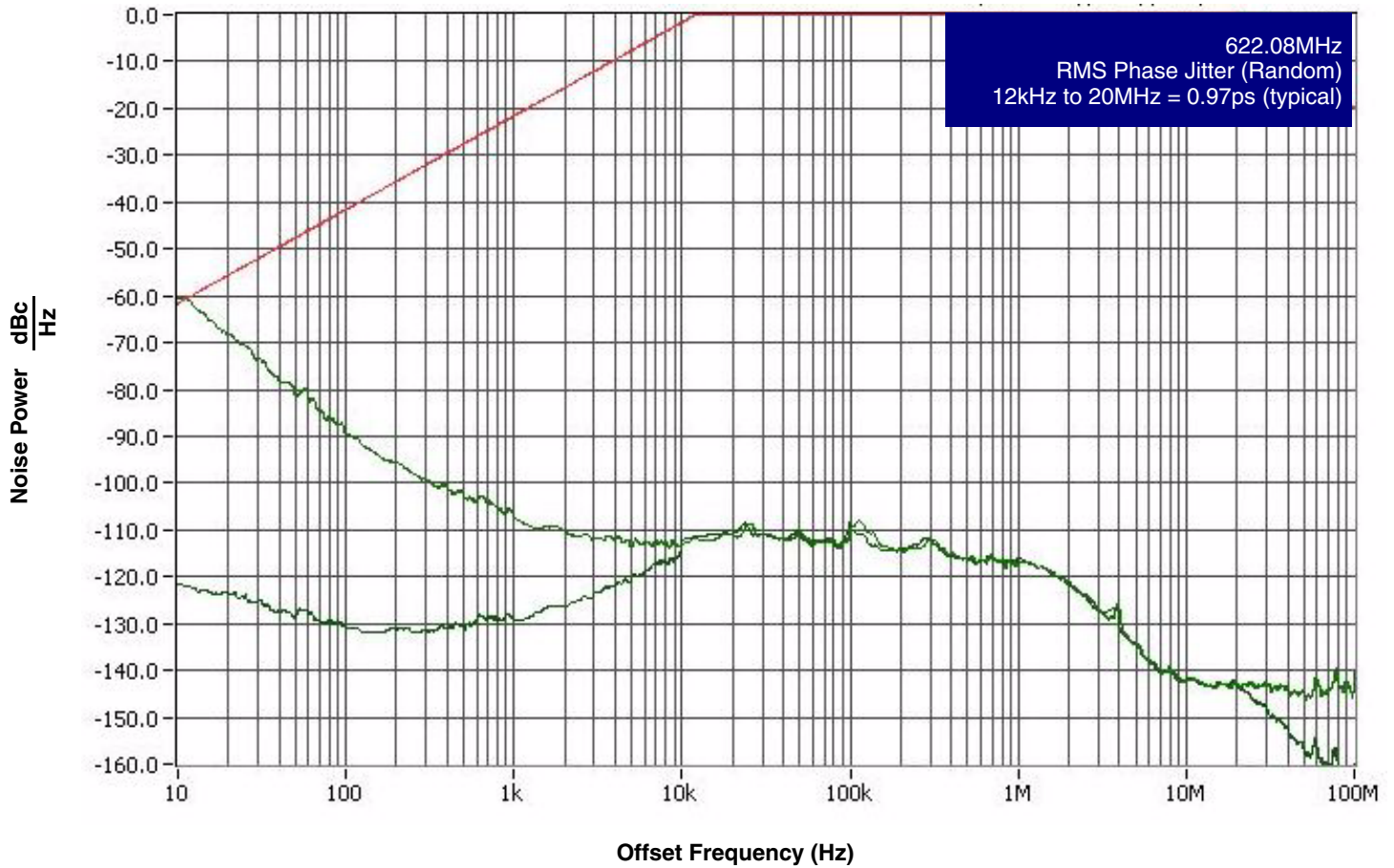

Parameter Measurement Information

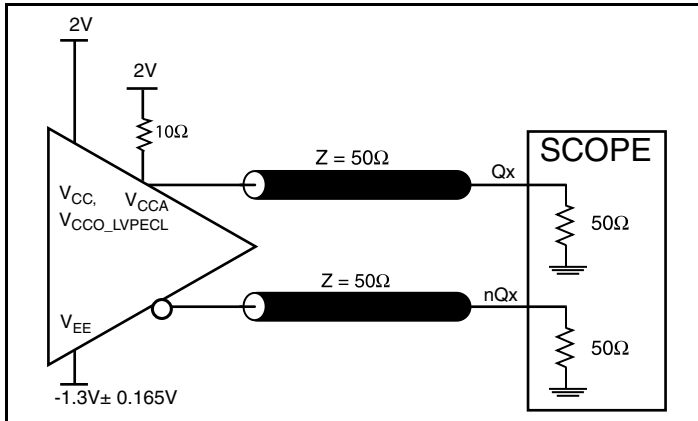

3.3V LVPECL Output Load AC Test Circuit

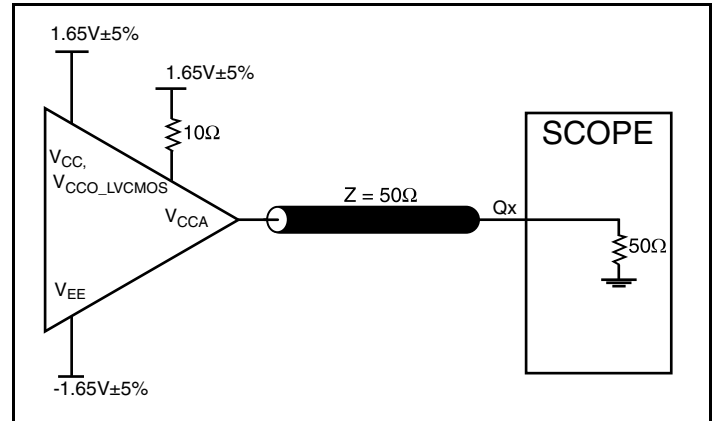

3.3V LVCMOS Output Load AC Test Circuit

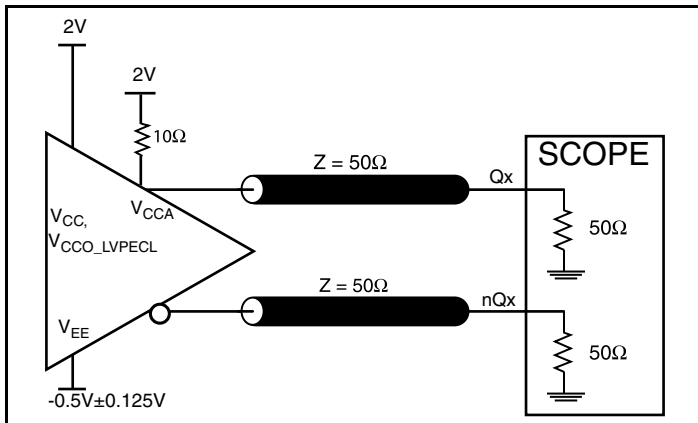

2.5V LVPECL Output Load AC Test Circuit

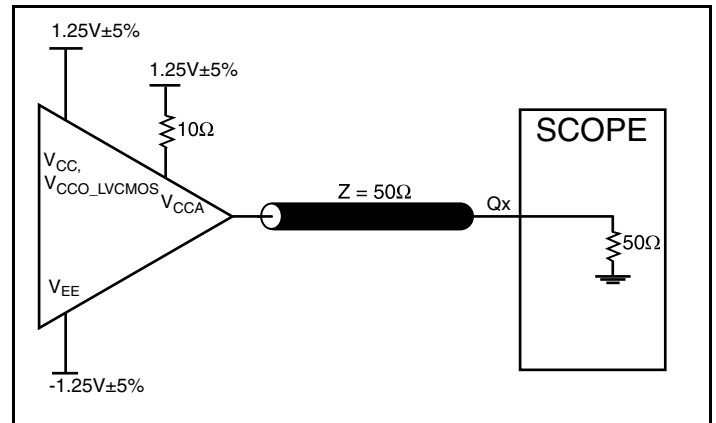

2.5V LVCMOS Output Load AC Test Circuit

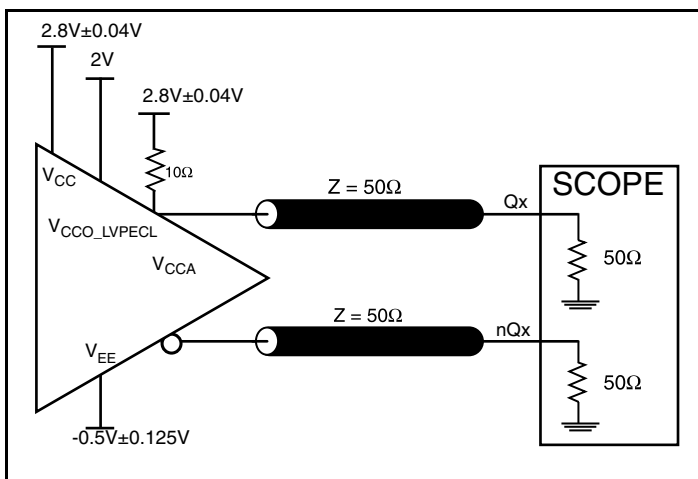

3.3 Core/2.5V LVPECL Output Load AC Test Circuit

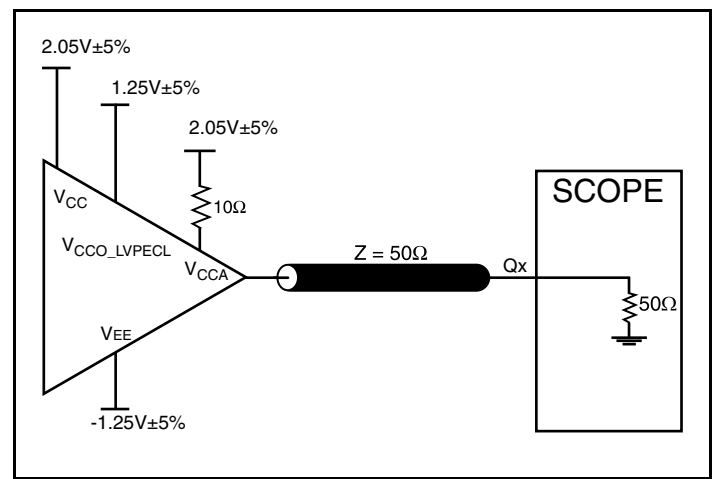

3.3V Core/2.5V LVCMOS Output Load AC Test Circuit

Parameter Measurement Information, continued

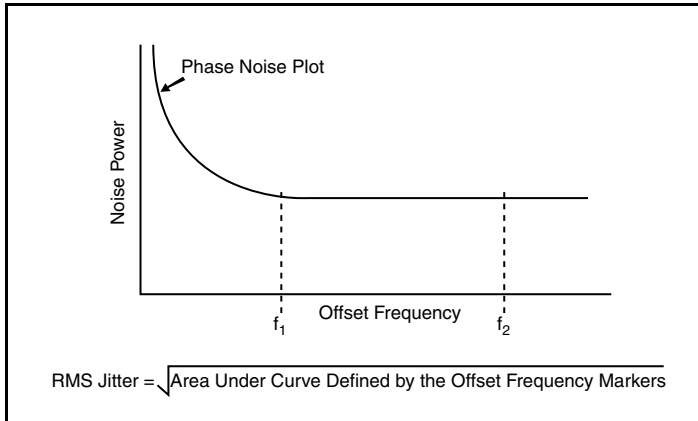

RMS Phase Jitter

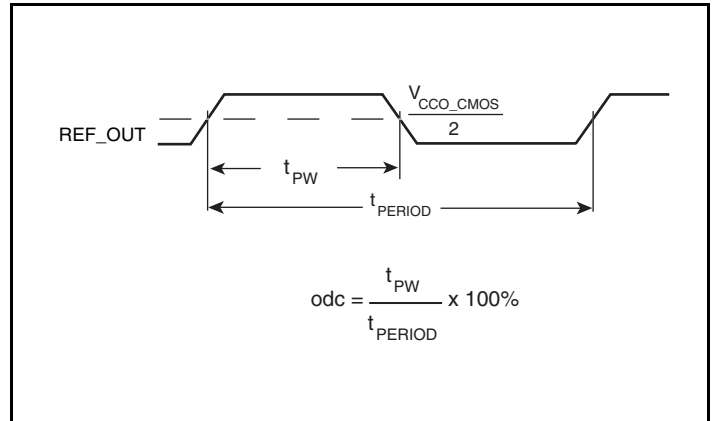

LVCMOS Output Duty Cycle/Pulse Width/Period

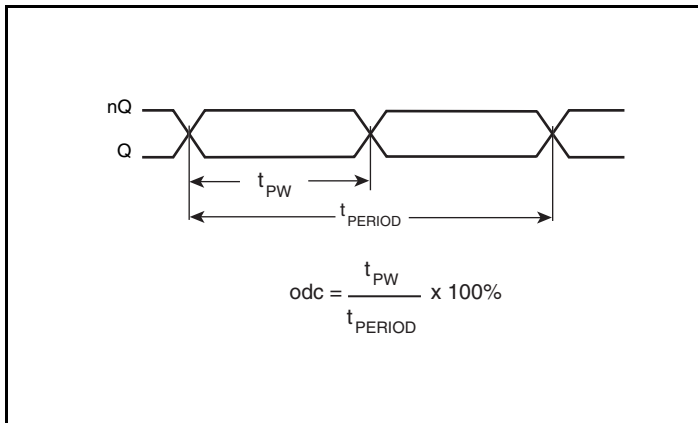

LVPECL Output Duty Cycle/Pulse Width/Period

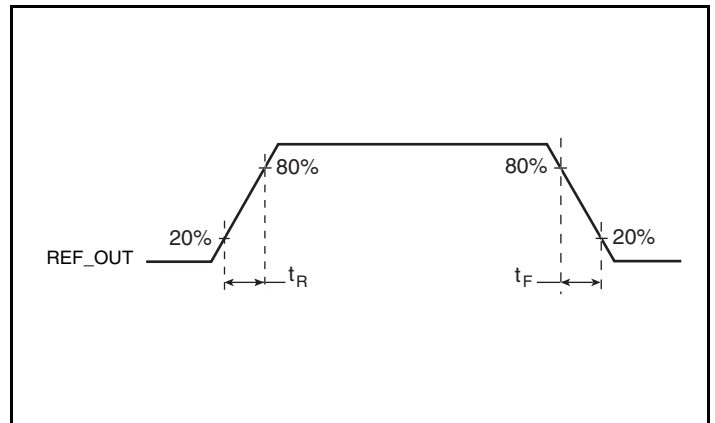

LVCMOS Output Rise/Fall Time

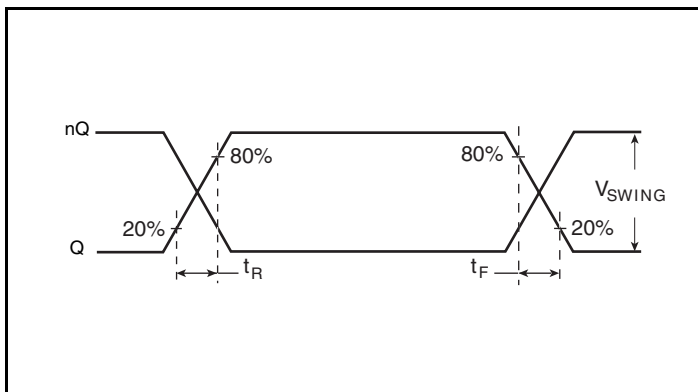

LVPECL Output Rise/Fall Time

Applications Information

Recommendations for Unused Input and Output Pins

Inputs:

Crystal Inputs

For applications not requiring the use of the crystal oscillator input, both XTAL_IN and XTAL_OUT can be left floating. Though not required, but for additional protection, a 1k Ω resistor can be tied from XTAL_IN to ground.

CLK Input

For applications not requiring the use of the clock input, it can be left floating. Though not required, but for additional protection, a 1k Ω resistor can be tied from the CLK input to ground.

LVCMOS Control Pins

All control pins have internal pullups or pulldowns; additional resistance is not required but can be added for additional protection. A 1k Ω resistor can be used.

Outputs:

LVPECL Outputs

The unused LVPECL output pair can be left floating. We recommend that there is no trace attached. Both sides of the differential output pair should either be left floating or terminated.

LVCMOS Output

All unused LVCMOS output can be left floating. We recommend that there is no trace attached.

Overdriving the XTAL Interface

The XTAL_IN input can accept a single-ended LVCMOS signal through an AC coupling capacitor. A general interface diagram is shown in *Figure 1A*. The XTAL_OUT pin can be left floating. The maximum amplitude of the input signal should not exceed 2V and the input edge rate can be as slow as 10ns. This configuration requires that the output impedance of the driver (R_o) plus the series resistance (R_s) equals the transmission line impedance. In addition,

matched termination at the crystal input will attenuate the signal in half. This can be done in one of two ways. First, R_1 and R_2 in parallel should equal the transmission line impedance. For most 50Ω applications, R_1 and R_2 can be 100Ω . This can also be accomplished by removing R_1 and making R_2 50Ω . By overdriving the crystal oscillator, the device will be functional, but note, the device performance is guaranteed by using a quartz crystal.

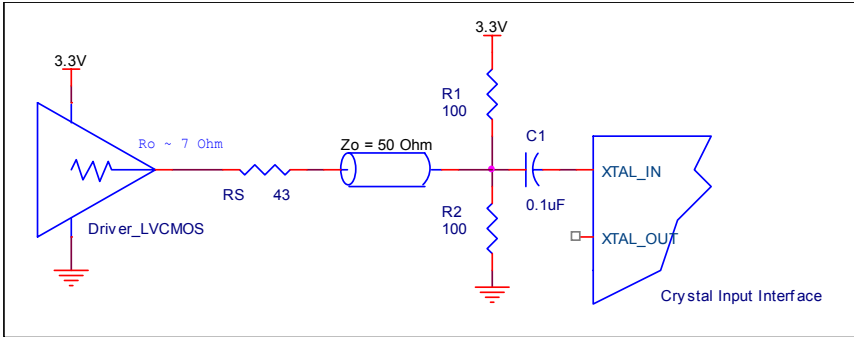

Figure 1A. General Diagram for LVCMOS Driver to XTAL Input Interface

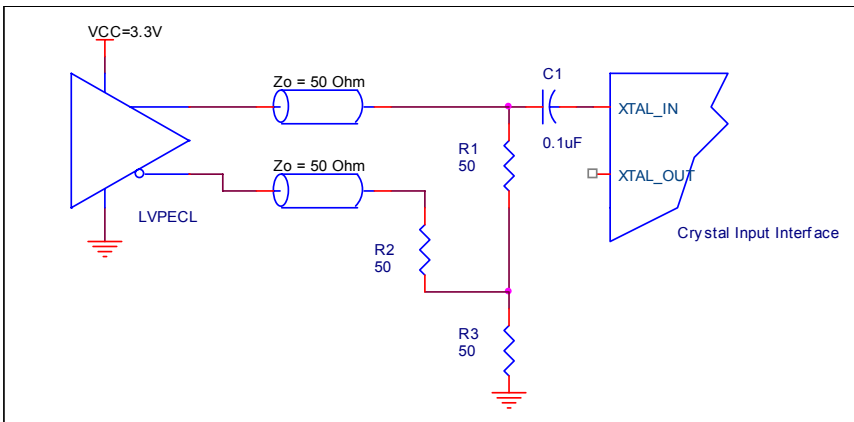

Figure 1B. General Diagram for LVPECL Driver to XTAL Input Interface

Termination for 3.3V LVPECL Outputs

The clock layout topology shown below is a typical termination for LVPECL outputs. The two different layouts mentioned are recommended only as guidelines.

The differential outputs are low impedance follower outputs that generate ECL/LVPECL compatible outputs. Therefore, terminating resistors (DC current path to ground) or current sources must be used for functionality. These outputs are designed to drive 50Ω

transmission lines. Matched impedance techniques should be used to maximize operating frequency and minimize signal distortion.

Figures 2A and 2B show two different layouts which are recommended only as guidelines. Other suitable clock layouts may exist and it would be recommended that the board designers simulate to guarantee compatibility across all printed circuit and clock component process variations.

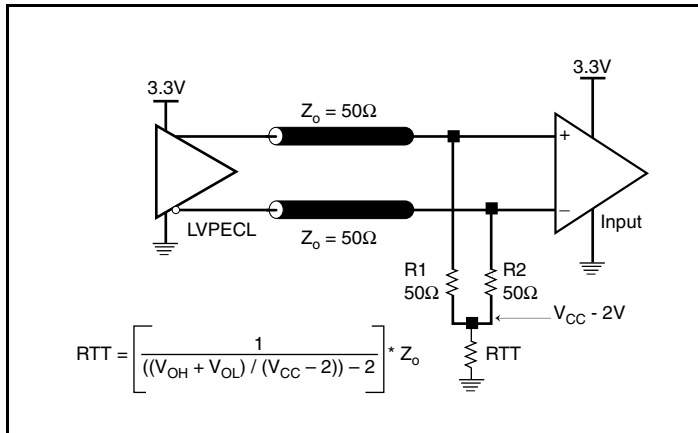

Figure 2A. 3.3V LVPECL Output Termination

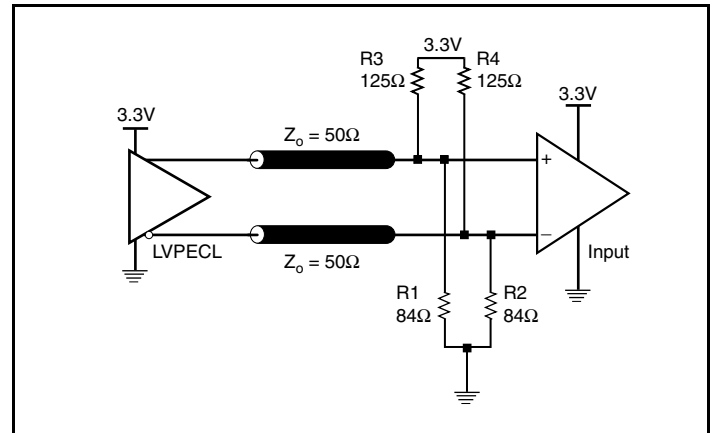

Figure 2B. 3.3V LVPECL Output Termination

Termination for 2.5V LVPECL Outputs

Figure 3A and Figure 3B show examples of termination for 2.5V LVPECL driver. These terminations are equivalent to terminating 50Ω to $V_{CC0} - 2V$. For $V_{CC0} = 2.5V$, the $V_{CC0} - 2V$ is very close to

ground level. The R3 in Figure 3B can be eliminated and the termination is shown in Figure 3C.

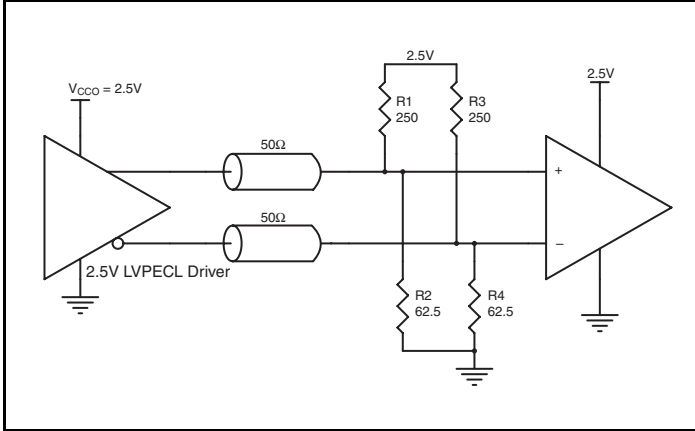

Figure 3A. 2.5V LVPECL Driver Termination Example

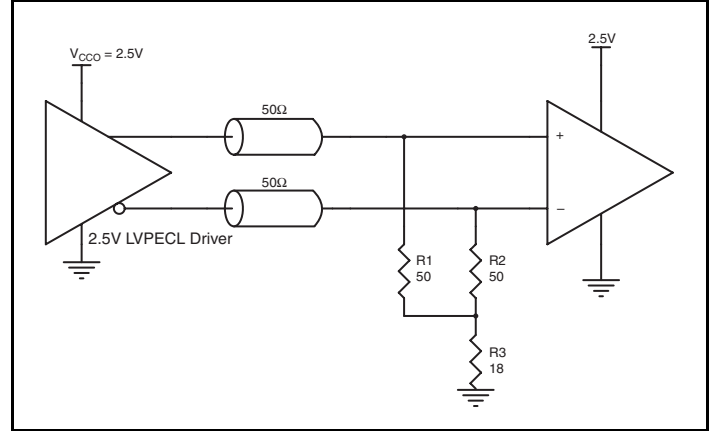

Figure 3B. 2.5V LVPECL Driver Termination Example

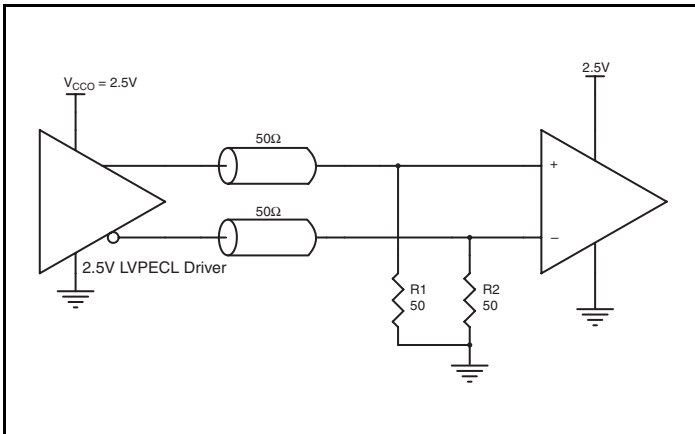

Figure 3C. 2.5V LVPECL Driver Termination Example

Schematic Layout

Figure 6 (next page) shows an example of ICS843001I-23 application schematic. In this example, the device is operated $V_{CC} = V_{CCO_LVCMOS} = V_{CCO_LVPECL} = 3.3V$. The 18pF parallel resonant 17.5-29.54MHz crystal is used. The load capacitance $C1 = 22pF$ and $C2 = 22pF$ are recommended for frequency accuracy. Depending on the parasitic of the printed circuit board layout, these values might require a slight adjustment to optimize the frequency accuracy. Crystals with other load capacitance specifications can be used. This will require adjusting $C1$ and $C2$. For this device, the crystal load capacitors are required for proper operation.

As with any high speed analog circuitry, the power supply pins are vulnerable to random noise. To achieve optimum jitter performance, power supply isolation is required. The ICS843001I-23 provides separate power supplies to isolate any high switching noise from coupling into the internal PLL.

In order to achieve the best possible filtering, it is recommended that the placement of the filter components be on the device side of the PCB as close to the power pins as possible. If space is limited, the

0.1uF capacitor in each power pin filter should be placed on the device side. The other components can be on the opposite side of the PCB.

Power supply filter recommendations are a general guideline to be used for reducing external noise from coupling into the devices. The filter performance is designed for wide range of noise frequency. This low-pass filter starts to attenuate noise at approximately 10kHz. If a specific frequency noise component with high amplitude interference is known, such as switching power supplies frequencies, it is recommended that component values be adjusted and if required, additional filtering be added. Additionally general design practice for power plane voltage stability suggests adding bulk capacitances in the general area of all devices.

The schematic example focuses on functional connections and is not configuration specific. Refer to the pin description and functional tables in the datasheet to ensure the logic control inputs are properly set.

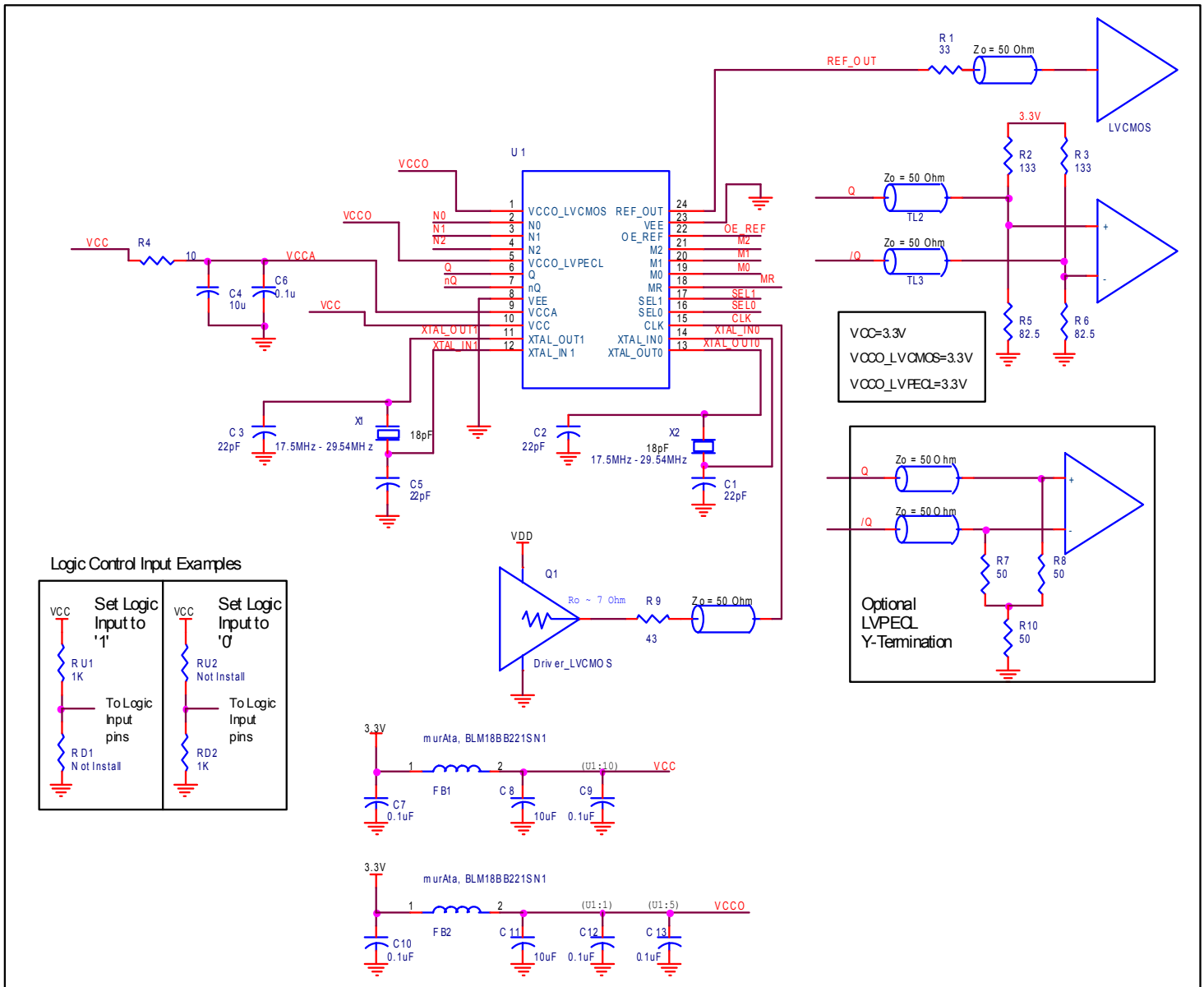

Figure 6. ICS843001I-23 Layout Example

EPAD Thermal Release Path

In order to maximize both the removal of heat from the package and the electrical performance, a land pattern must be incorporated on the Printed Circuit Board (PCB) within the footprint of the package corresponding to the exposed metal pad or exposed heat slug on the package, as shown in *Figure 7*. The solderable area on the PCB, as defined by the solder mask, should be at least the same size/shape as the exposed pad/slug area on the package to maximize the thermal/electrical performance. Sufficient clearance should be designed on the PCB between the outer edges of the land pattern and the inner edges of pad pattern for the leads to avoid any shorts.

While the land pattern on the PCB provides a means of heat transfer and electrical grounding from the package to the board through a solder joint, thermal vias are necessary to effectively conduct from the surface of the PCB to the ground plane(s). The land pattern must be connected to ground through these vias. The vias act as “heat pipes”. The number of vias (i.e. “heat pipes”) are application specific

and dependent upon the package power dissipation as well as electrical conductivity requirements. Thus, thermal and electrical analysis and/or testing are recommended to determine the minimum number needed. Maximum thermal and electrical performance is achieved when an array of vias is incorporated in the land pattern. It is recommended to use as many vias connected to ground as possible. It is also recommended that the via diameter should be 12 to 13mils (0.30 to 0.33mm) with 1oz copper via barrel plating. This is desirable to avoid any solder wicking inside the via during the soldering process which may result in voids in solder between the exposed pad/slug and the thermal land. Precautions should be taken to eliminate any solder voids between the exposed heat slug and the land pattern. Note: These recommendations are to be used as a guideline only. For further information, refer to the Application Note on the *Surface Mount Assembly* of Amkor’s Thermally/Electrically Enhance Leadframe Base Package, Amkor Technology.

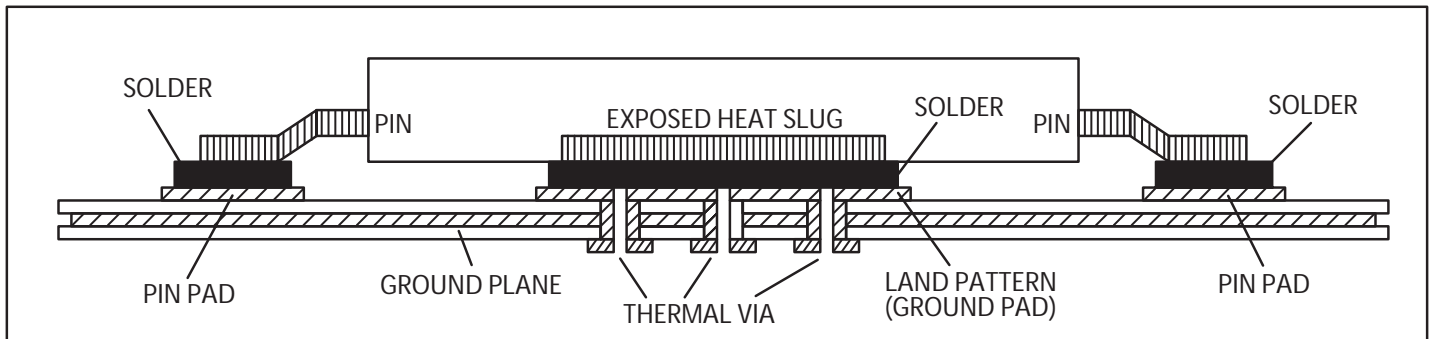

Figure 7. Assembly for Exposed Pad Thermal Release Path - Side View (drawing not to scale)

Power Considerations

This section provides information on power dissipation and junction temperature for the ICS8430011-23. Equations and example calculations are also provided.

1. Power Dissipation.

The total power dissipation for the ICS8430011-23 is the sum of the core power plus the power dissipated in the load(s). The following is the power dissipation for $V_{CC} = 3.3V + 5\% = 3.465V$, which gives worst case results.

NOTE: Please refer to Section 3 for details on calculating power dissipated in the load.

- Power (core)_{MAX} = $V_{CC_MAX} * I_{EE_MAX} = 3.465V * 140mA = 485.1mW$
- Power (outputs)_{MAX} = **30mW/Loaded Output pair**

LVCMOS Output Power Dissipation

- Output Impedance R_{OUT} Power Dissipation due to Loading 50Ω to $V_{DDO}/2$
Output Current $I_{OUT} = V_{DDO_MAX} / [2 * (50\Omega + R_{OUT})] = 3.465V / [2 * (50\Omega + 21\Omega)] = 24.4mA$
- Power Dissipation on the R_{OUT} per LVCMOS output
Power (R_{OUT}) = $R_{OUT} * (I_{OUT})^2 = 21\Omega * (24.4mA)^2 = 12.5mW$ per output

Total Power Dissipation

- **Total Power**
= Power (core) + Power (LVPECL output) + Power (R_{OUT})
= $485.1mW + 30mW + 12.5mW = 527.6mW$

2. Junction Temperature.

Junction temperature, T_j , is the temperature at the junction of the bond wire and bond pad, and directly affects the reliability of the device. The maximum recommended junction temperature is $125^\circ C$. Limiting the internal transistor junction temperature, T_j , to $125^\circ C$ ensures that the bond wire and bond pad temperature remains below $125^\circ C$.

The equation for T_j is as follows: $T_j = \theta_{JA} * Pd_total + T_A$

T_j = Junction Temperature

θ_{JA} = Junction-to-Ambient Thermal Resistance

Pd_total = Total Device Power Dissipation (example calculation is in section 1 above)

T_A = Ambient Temperature

In order to calculate junction temperature, the appropriate junction-to-ambient thermal resistance θ_{JA} must be used. Assuming no air flow and a multi-layer board, the appropriate value is $32.1^\circ C/W$ per Table 7 below.

Therefore, T_j for an ambient temperature of $85^\circ C$ with all outputs switching is:

$$85^\circ C + 0.528W * 32.1^\circ C/W = 102^\circ C. \text{ This is below the limit of } 125^\circ C.$$

This calculation is only an example. T_j will obviously vary depending on the number of loaded outputs, supply voltage, air flow and the type of board (multi-layer).

Table 7. Thermal Resistance θ_{JA} for 24 Lead TSSOP, E-Pad Forced Convection

θ_{JA} vs. Air Flow			
Meters per Second	0	1	2.5
Multi-Layer PCB, JEDEC Standard Test Boards	$32.1^\circ C/W$	$25.5^\circ C/W$	$24.0^\circ C/W$

3. Calculations and Equations.

The purpose of this section is to calculate the power dissipation for the LVPECL output pair.

LVPECL output driver circuit and termination are shown in *Figure 7*.

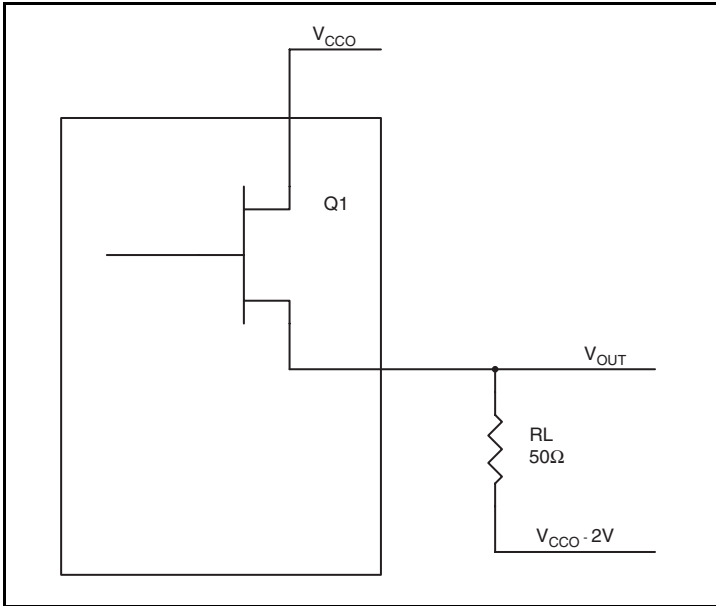

Figure 8. LVPECL Driver Circuit and Termination

To calculate worst case power dissipation into the load, use the following equations which assume a 50Ω load, and a termination voltage of V_{CCO} - 2V.

- For logic high, V_{OUT} = V_{OH_MAX} = V_{CCO_MAX} - 0.9V
(V_{CCO_MAX} - V_{OH_MAX}) = 0.9V
- For logic low, V_{OUT} = V_{OL_MAX} = V_{CCO_MAX} - 1.7V
(V_{CCO_MAX} - V_{OL_MAX}) = 1.7V

Pd_H is power dissipation when the output drives high.

Pd_L is the power dissipation when the output drives low.

$$Pd_H = [(V_{OH_MAX} - (V_{CCO_MAX} - 2V))/R_L] * (V_{CCO_MAX} - V_{OH_MAX}) = [(2V - (V_{CCO_MAX} - V_{OH_MAX}))/R_L] * (V_{CCO_MAX} - V_{OH_MAX}) = [(2V - 0.9V)/50\Omega] * 0.9V = \mathbf{19.8mW}$$

$$Pd_L = [(V_{OL_MAX} - (V_{CCO_MAX} - 2V))/R_L] * (V_{CCO_MAX} - V_{OL_MAX}) = [(2V - (V_{CCO_MAX} - V_{OL_MAX}))/R_L] * (V_{CCO_MAX} - V_{OL_MAX}) = [(2V - 1.7V)/50\Omega] * 1.7V = \mathbf{10.2mW}$$

$$\text{Total Power Dissipation per output pair} = Pd_H + Pd_L = \mathbf{30mW}$$

Reliability Information

Table 8. θ_{JA} vs. Air Flow Table for a 24 Lead TSSOP, E-pad

θ_{JA} vs. Air Flow			
Meters per Second	0	1	2.5
Multi-Layer PCB, JEDEC Standard Test Boards	32.1°C/W	25.5°C/W	24.0°C/W

Transistor Count

The transistor count for ICS843001I-23 is: 4165

Package Outline and Package Dimensions

Package Outline - G Suffix for 24 Lead TSSOP, E-Pad

Table 9. Package Dimensions

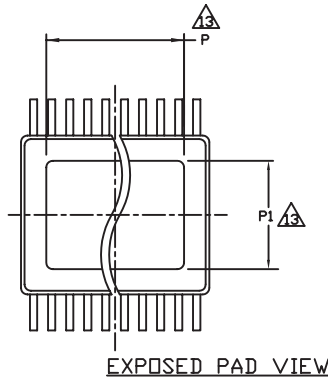
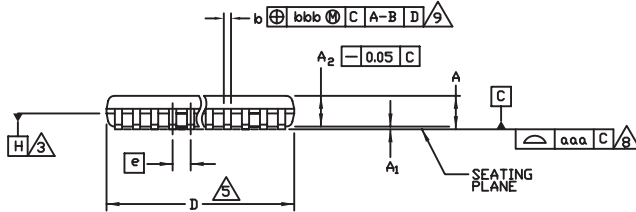
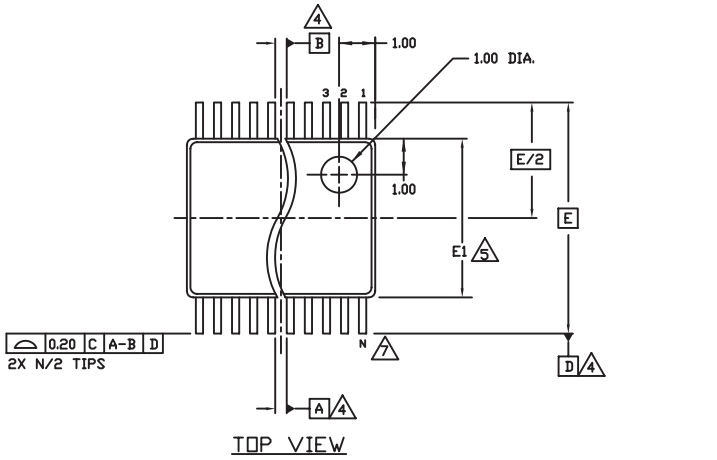

All Dimensions in Millimeters		
Symbol	Minimum	Maximum
N	24	
A		1.10
A1	0.05	0.15
A2	0.85	0.95
b	0.19	0.30
b1	0.19	0.25
c	0.09	0.20
c1	0.09	0.16
D	7.70	7.90
E	6.40 Basic	
E1	4.30	4.50
e	0.65 Basic	
L	0.50	0.70
P	5.0	5.5
P1	3.0	3.2
α	0°	8°
aaa	0.076	
bbb	0.10	

Reference Document: JEDEC Publication 95, MO-153

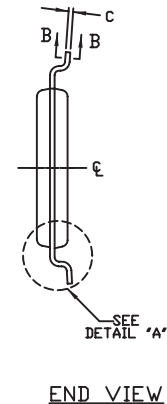
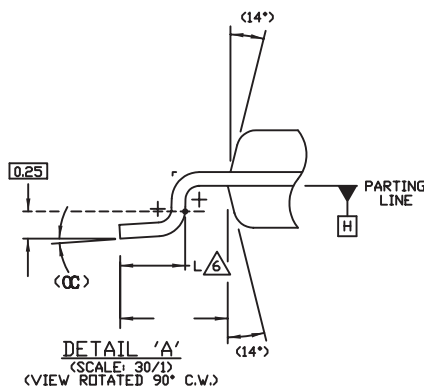
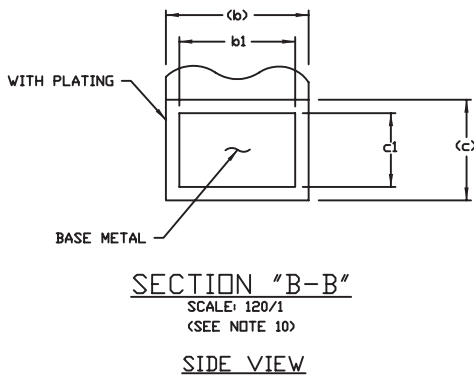
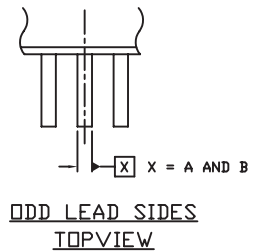
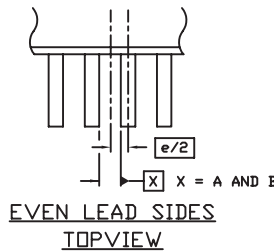

Ordering Information

Table 10. Ordering Information

Part/Order Number	Marking	Package	Shipping Packaging	Temperature
843001CGI-23	ICS843001CI23	24 Lead TSSOP, E-Pad	Tube	-40°C to 85°C
843001CGI-23T	ICS843001CI23	24 Lead TSSOP, E-Pad	2500 Tape & Reel	-40°C to 85°C
843001CGI-23LF	ICS43001CI23L	"Lead-Free" 24 Lead TSSOP, E-Pad	Tube	-40°C to 85°C
843001CGI-23LFT	ICS43001CI23L	"Lead-Free" 24 Lead TSSOP, E-Pad	2500 Tape & Reel	-40°C to 85°C

NOTE: Parts that are ordered with an "LF" suffix to the part number are the Pb-Free configuration and are RoHS compliant.

While the information presented herein has been checked for both accuracy and reliability, Integrated Device Technology (IDT) assumes no responsibility for either its use or for the infringement of any patents or other rights of third parties, which would result from its use. No other circuits, patents, or licenses are implied. This product is intended for use in normal commercial and industrial applications. Any other applications, such as those requiring high reliability or other extraordinary environmental requirements are not recommended without additional processing by IDT. IDT reserves the right to change any circuitry or specifications without notice. IDT does not authorize or warrant any IDT product for use in life support devices or critical medical instruments.

We've Got Your Timing Solution



6024 Silver Creek Valley Road
San Jose, California 95138

Sales
800-345-7015 (inside USA)
+408-284-8200 (outside USA)
Fax: 408-284-2775
www.IDT.com/go/contactIDT

Technical Support
netcom@idt.com
+480-763-2056

DISCLAIMER Integrated Device Technology, Inc. (IDT) and its subsidiaries reserve the right to modify the products and/or specifications described herein at any time and at IDT's sole discretion. All information in this document, including descriptions of product features and performance, is subject to change without notice. Performance specifications and the operating parameters of the described products are determined in the independent state and are not guaranteed to perform the same way when installed in customer products. The information contained herein is provided without representation or warranty of any kind, whether express or implied, including, but not limited to, the suitability of IDT's products for any particular purpose, an implied warranty of merchantability, or non-infringement of the intellectual property rights of others. This document is presented only as a guide and does not convey any license under intellectual property rights of IDT or any third parties.

IDT's products are not intended for use in life support systems or similar devices where the failure or malfunction of an IDT product can be reasonably expected to significantly affect the health or safety of users. Anyone using an IDT product in such a manner does so at their own risk, absent an express, written agreement by IDT.

Integrated Device Technology, IDT and the IDT logo are registered trademarks of IDT. Other trademarks and service marks used herein, including protected names, logos and designs, are the property of IDT or their respective third party owners.

Copyright 2011. All rights reserved.