

Low frequency transistor (50V, 2A)

2SC5585 / 2SC5663

The transistor of 500mA class which went only into 2125 size conventionally was attained in 1608 sizes or 1208 sizes.

●Applications

For switching
For muting

●Features

- 1) High current.
- 2) Low $V_{CE(sat)}$.

$$V_{CE(sat)} \leq 250\text{mV at } I_C = 200\text{mA} / I_B = 10\text{mA}$$

●External dimensions (Units : mm)

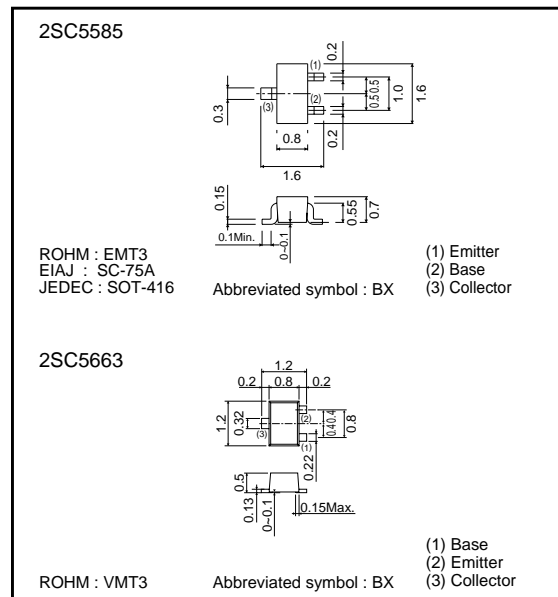

●Absolute maximum ratings (Ta=25°C)

Parameter	Symbol	Limits	Unit
Collector-base voltage	V_{CBO}	15	V
Collector-emitter voltage	V_{CEO}	12	V
Collector current	I_C	500	mA
	I_{CP}	1	A *
Collector power dissipation	P_C	150	mW
Junction temperature	T_j	150	°C
Storage temperature	T_{stg}	-55~+150	°C

* Single pulse $P_w = 1\text{ms}$

●Electrical characteristics (Ta=25°C)

Parameter	Symbol	Min.	Typ.	Max.	Unit	Conditions
Collector-base breakdown voltage	BV_{CBO}	15	-	-	V	$I_C = 10\mu\text{A}$
Collector-emitter breakdown voltage	BV_{CEO}	12	-	-	V	$I_C = 1\text{mA}$
Emitter-base breakdown voltage	BV_{EBO}	6	-	-	V	$I_E = 10\mu\text{A}$
Collector cutoff current	I_{CBO}	-	-	100	nA	$V_{CB} = 15\text{V}$
Collector-emitter saturation voltage	$V_{CE(sat)}$	-	90	250	mV	$I_C/I_E = 200\text{mA}/10\text{mA}$
DC current transfer ratio	h_{FE}	270	-	680	-	$V_{CE} = 2\text{V}, I_C = 10\text{mA}$
Transition frequency	f_T	-	320	-	MHz	$V_{CE} = 2\text{V}, I_E = -10\text{mA}, f = 100\text{MHz}$
Output capacitance	C_{ob}	-	7.5	-	pF	$V_{CB} = 10\text{V}, I_E = 0\text{A}, f = 1\text{MHz}$

Transistors

●Packaging specifications

Type	hFE	Package	Taping	
		Code	TL	T2L
		Basic ordering unit (pieces)	3000	8000
2SC5585			○	—
2SC5663			—	○

●Electrical characteristic curves

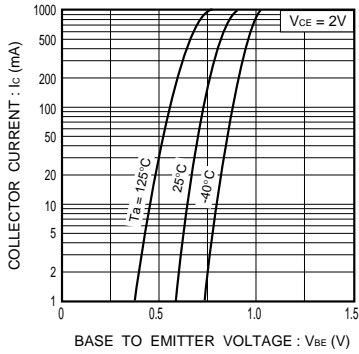

Fig.1 Grounded emitter propagation characteristics

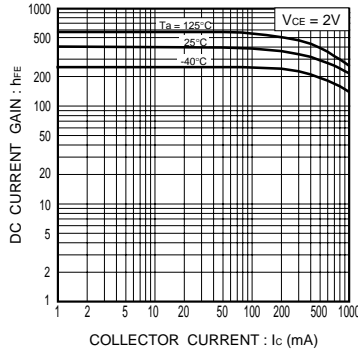

Fig.2 DC current gain vs. collector current

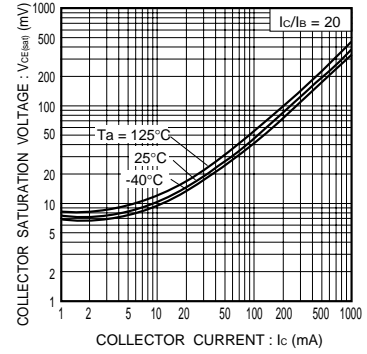

Fig.3 Collector-emitter saturation voltage vs. collector current (I)

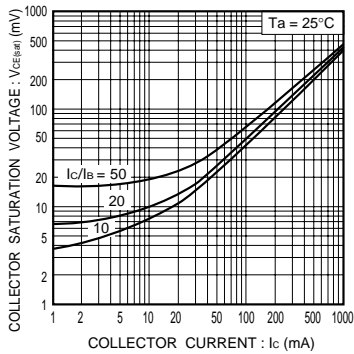

Fig.4 Collector-emitter saturation voltage vs. collector current (II)

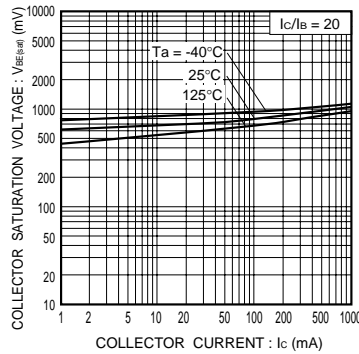

Fig.5 Base-emitter saturation voltage vs. collector current

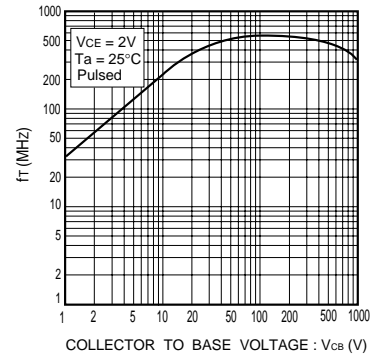

Fig.6 Collector output capacitance Emitter input capacitance vs. base voltage

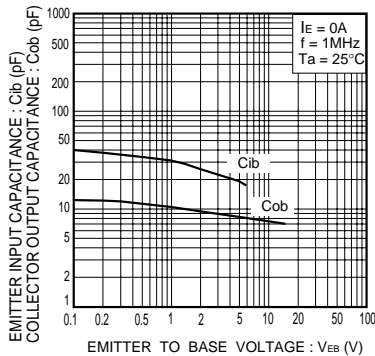

Fig.7 Collector output capacitance vs collector-base voltage Emitter input capacitance vs emitter-base voltage