

DIM	INCHES			MILLIMETERS		
	MIN	NOM	MAX	MIN	NOM	MAX
A	.053	.063	.069	1.35	1.60	1.75
A1	.004	.007	.010	0.102	0.169	0.254
A2	.049	.058	.065	1.245	1.473	1.651
B	.008	.010	.012	0.20	0.25	0.30
C	.0075	.0087	.0098	0.191	0.222	0.249
D	SEE VARIATIONS					
E	.150	.153	.157	3.81	3.89	3.99
e	.025 BSC			0.635 BSC		
H	.230	.236	.244	5.84	6.00	6.20
h	.010	---	.016	0.25	---	0.41
L	.016	.025	.035	0.41	0.64	0.89
N	SEE VARIATIONS					
α	0°	---	8°	0°	---	8°

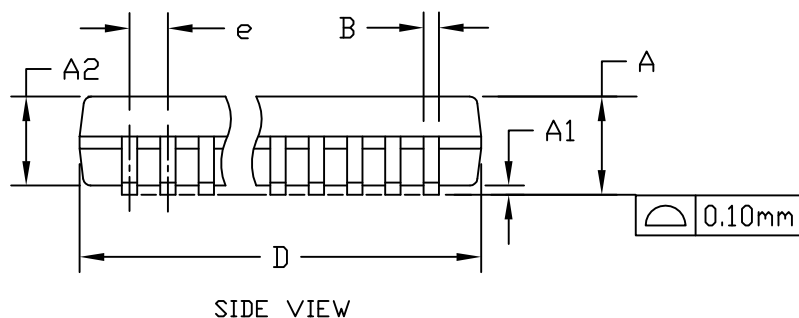

VARIATIONS:

	INCHES			MILLIMETERS			N	PKG CODES
	MIN.	NOM	MAX.	MIN.	NOM	MAX.		
D	.189	.193	.196	4.80	4.90	4.98	16	E16-1, E16M-1, E16-4, E16-5, E16-8F
S	.0020	.0033	.0070	0.05	0.08	0.18		
D	.337	.341	.344	8.56	8.66	8.74	20	E20-1, E20-2, E20-3
S	.0500	.0535	.0550	1.270	1.270	1.397		
D	.337	.340	.344	8.56	8.64	8.74	24	E24-1, E24-2, E24-3
S	.0250	.0280	.0300	0.635	0.711	0.762		
D	.386	.390	.393	9.80	9.91	9.98	28	E28-1, E28M-1, E28-2
S	.0250	.0274	.0300	0.635	0.696	0.762		

NOTES:

1. D & E DO NOT INCLUDE MOLD FLASH OR PROTRUSIONS.
2. MOLD FLASH OR PROTRUSIONS NOT TO EXCEED .006" PER SIDE.
3. CONTROLLING DIMENSIONS: INCHES.
4. MEETS JEDEC MO137.
5. MARKING SHOWN IS FOR PKG. ORIENTATION ONLY.
6. ALL DIMENSIONS APPLY TO BOTH LEADED (-) AND PbFREE (+) PKG. CODES.



TITLE:
PACKAGE OUTLINE
QSDP .150", .025" LEAD PITCH

APPROVAL	DOCUMENT CONTROL NO. 21-0055	REV. K	1/1
----------	---------------------------------	-----------	-----

-DRAWING NOT TO SCALE-