

Silicon N-Channel MOSFET

Features

- 24A,500V, $R_{DS(on)}$ (Max0.19 Ω)@ $V_{GS}=10V$
- Ultra-low Gate charge(Typical 90nC)
- Fast Switching Capability
- 100%Avalanche Tested
- Maximum Junction Temperature Range(150 $^{\circ}C$)

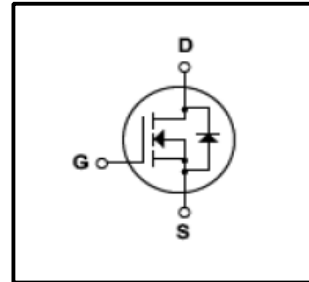

General Description

This N-Channel enhancement mode power field effect transistors are produced using Winsemi's proprietary, planar stripe ,DMOS technology. This advanced technology has been especially tailored to minimize on-state resistance , provide superior switching performance, and withstand high energy pulse in the avalanche and commutation mode. These devices are well suited for high efficiency switch mode power supplies.

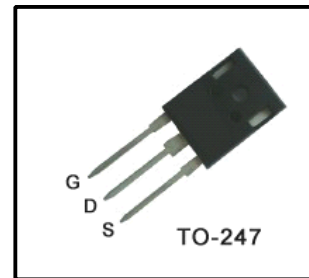

Absolute Maximum Ratings

Symbol	Parameter	Value	Units
V_{DSS}	Drain Source Voltage	500	V
I_D	Continuous Drain Current(@ $T_c=25^{\circ}C$)	24	A
	Continuous Drain Current(@ $T_c=100^{\circ}C$)	15.2	A
I_{DM}	Drain Current Pulsed (Note1)	96	A
V_{GS}	Gate to Source Voltage	± 30	V
E_{AS}	Single Pulsed Avalanche Energy (Note2)	1100	mJ
E_{AR}	Repetitive Avalanche Energy (Note1)	29	mJ
dv/dt	Peak Diode Recovery dv /dt (Note3)	4.5	V/ ns
P_D	Total Power Dissipation(@ $T_c=25^{\circ}C$)	290	W
	Derating Factor above 25 $^{\circ}C$	2.33	W/ $^{\circ}C$
T_J, T_{stg}	Junction and Storage Temperature	-55~150	$^{\circ}C$
T_L	Channel Temperature	300	$^{\circ}C$

Thermal Characteristics

Symbol	Parameter	Value			Units
		Min	Typ	Max	
R_{QJC}	Thermal Resistance , Junction -to -Case	-	-	0.43	$^{\circ}C/W$
R_{QCS}	Thermal Resistance , Case-to-Sink	-	0.24	-	$^{\circ}C/W$
R_{QJA}	Thermal Resistance , Junction-to -Ambient	-	-	40	$^{\circ}C/W$

Electrical Characteristics(Tc=25°C)

Characteristics	Symbol	Test Condition	Min	Type	Max	Unit	
Gate leakage current	I_{GSS}	$V_{GS}=\pm 25V, V_{DS}=0V$	-	-	± 100	nA	
Gate-source breakdown voltage	$V_{(BR)GSS}$	$I_G=\pm 10 \mu A, V_{DS}=0V$	± 30	-	-	V	
Drain cut -off current	I_{DSS}	$V_{DS}=500V, V_{GS}=0V$	-	-	1	μA	
		$V_{DS}=400V, T_c=125^\circ C$			10		
Drain -source breakdown voltage	$V_{(BR)DSS}$	$I_D=10 mA, V_{GS}=0V$	500	-	-	V	
Breakdown voltage Temperature coefficient	$\Delta BV_{DSS}/\Delta T_J$	$I_D=250\mu A, \text{Referenced to } 25^\circ C$	-	0.53	-	V/ $^\circ C$	
Gate threshold voltage	$V_{GS(th)}$	$V_{DS}=10V, I_D=1mA$	3.0	-	5.0	V	
Drain -source ON resistance	$R_{DS(ON)}$	$V_{GS}=10V, I_D=9A$	-	0.16	0.19	Ω	
Forward Transconductance	gfs	$V_{DS}=40V, I_D=9A$	-	22	-	S	
Input capacitance	C_{iss}	$V_{DS}=25V,$	-	3500	4500	pF	
Reverse transfer capacitance	C_{rss}	$V_{GS}=0V,$	-	55	70		
Output capacitance	C_{oss}	$f=1MHz$	-	520	670		
Switching time	Rise time	tr	$V_{DD}=250V,$ $I_D=18A$ $R_G=25\Omega$ (Note4,5)	-	250	500	ns
	Turn-on time	ton		-	80	170	
	Fall time	tf		-	155	320	
	Turn-off time	toff		-	200	400	
Total gate charge(gate-source plus gate-drain)	Qg	$V_{DD}=400V,$ $V_{GS}=10V,$	-	90	120	nC	
Gate-source charge	Qgs	$I_D=18A$	-	23	-		
Gate-drain("miller") Charge	Qgd	(Note4,5)	-	44	-		

Source-Drain Ratings and Characteristics(Ta=25°C)

Characteristics	Symbol	Test Condition	Min	Type	Max	Unit
Continuous drain reverse current	I_{DR}	-	-	-	24	A
Pulse drain reverse current	I_{DRP}	-	-	-	96	A
Forward voltage(diode)	V_{DSF}	$I_{DR}=24A, V_{GS}=0V$	-	-	1.4	V
Reverse recovery time	trr	$I_{DR}=24A, V_{GS}=0V,$	-	400	-	ns
Reverse recovery charge	Qrr	$dI_{DR} / dt = 100 A / \mu s$	-	4.3	-	μC

Note 1.Repeativity rating :pulse width limited by junction temperature

2.L=3.4mH $I_{AS}=24A, V_{DD}=50V, R_G=25\Omega, \text{Starting } T_J=25^\circ C$

3. $I_{SD}\leq 24A, di/dt\leq 200A/\mu s, V_{DD}<BV_{DSS}, \text{STARTING } T_J=25^\circ C$

4. Pulse Test:Pulse Width $\leq 300\mu s, \text{Duty Cycles}\leq 2\%$

5. Essentially independent of operating temperature.

This transistor is an electrostatic sensitive device

Please handle with caution

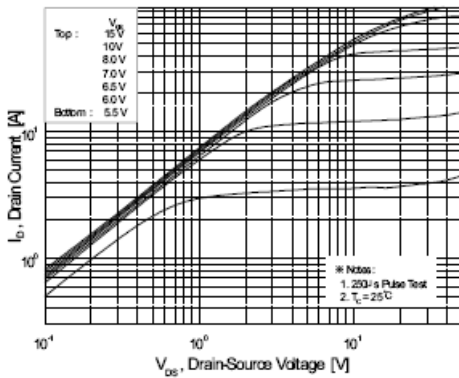

Fig.1 On State Characteristics

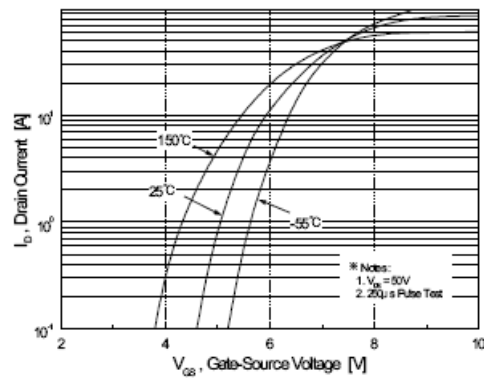

Fig.2 Transfer Current Characteristics

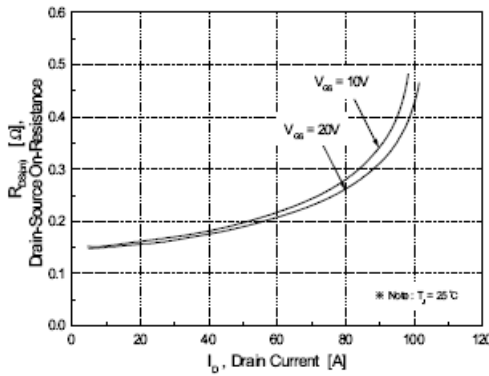

Fig.3 On-Resistance Variation vs Drain Current and gate voltage

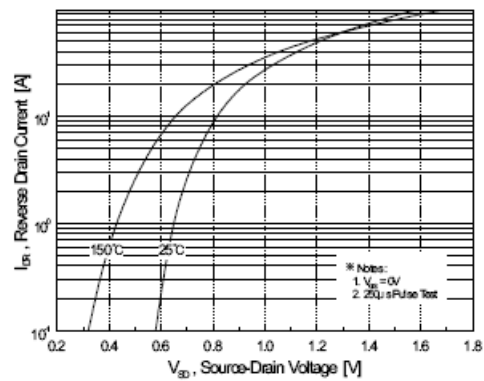

Fig.4 Body Diode Forward Voltage Variation with Source Current and Temperature

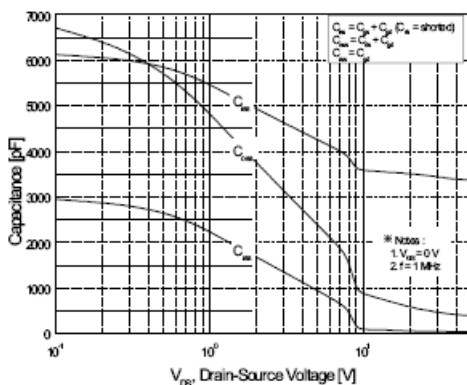

Fig.5 Capacitance Characteristics

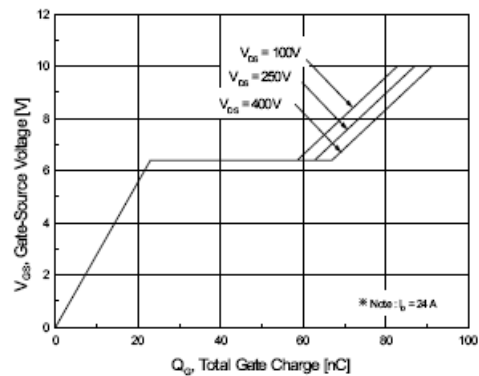

Fig.6 Gate Charge Characteristics

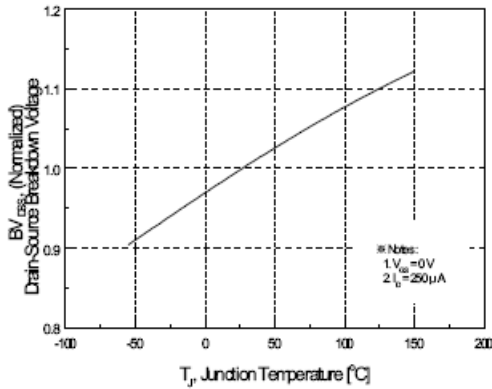

Fig.7 Breakdown Voltage Variation

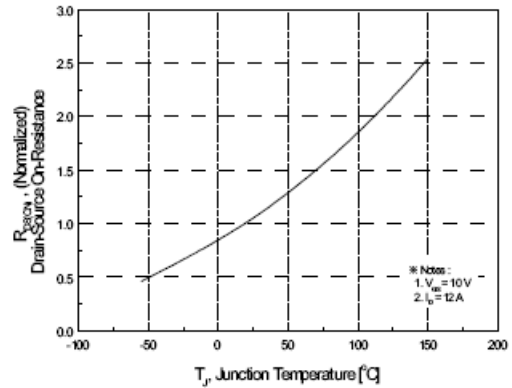

Fig.8 On-Resistance Variation vs. Temperature

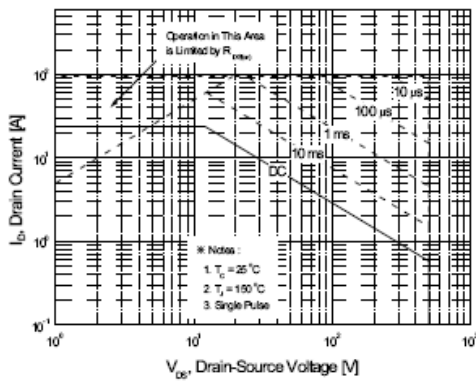

Fig.9 Maximum Safe Operation Area

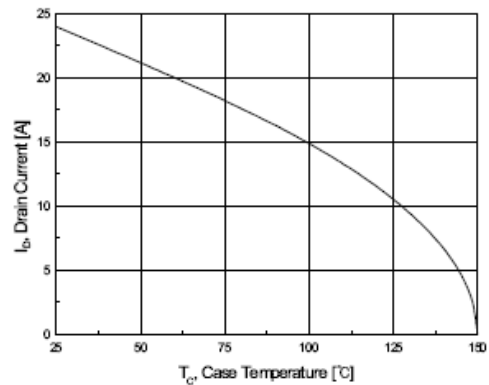

Fig.10 Maximum Drain Current vs Case Temperature

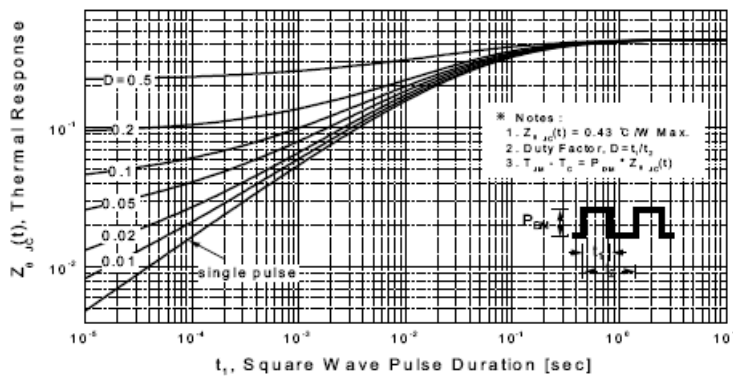

Fig.11 Transient Thermal Response Curve

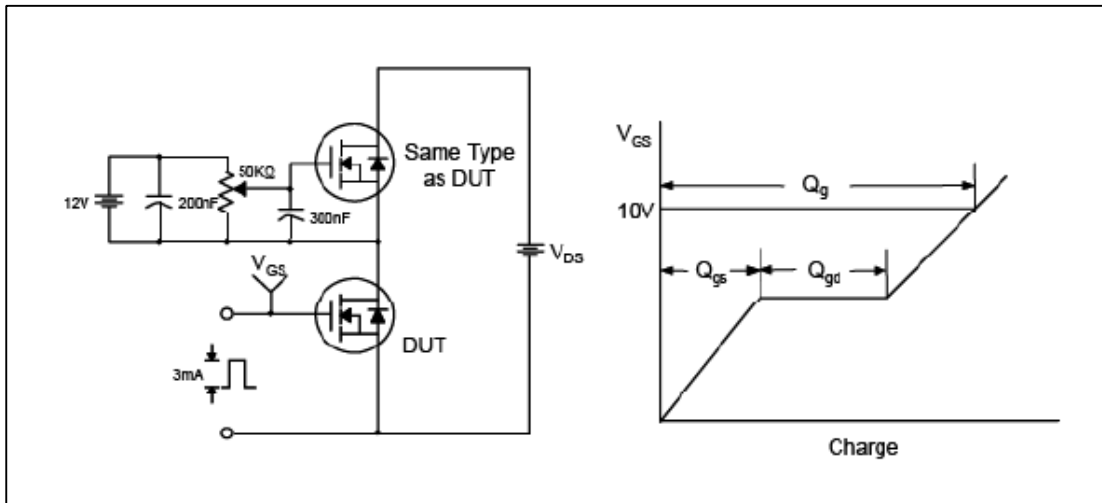

Fig.12 Gate Test Circuit & Waveform

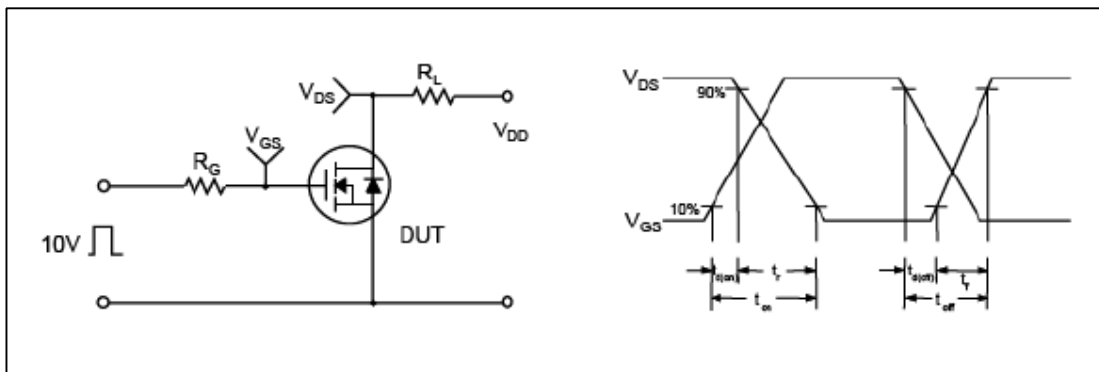

Fig.13 Resistive Switching Test Circuit & Waveform

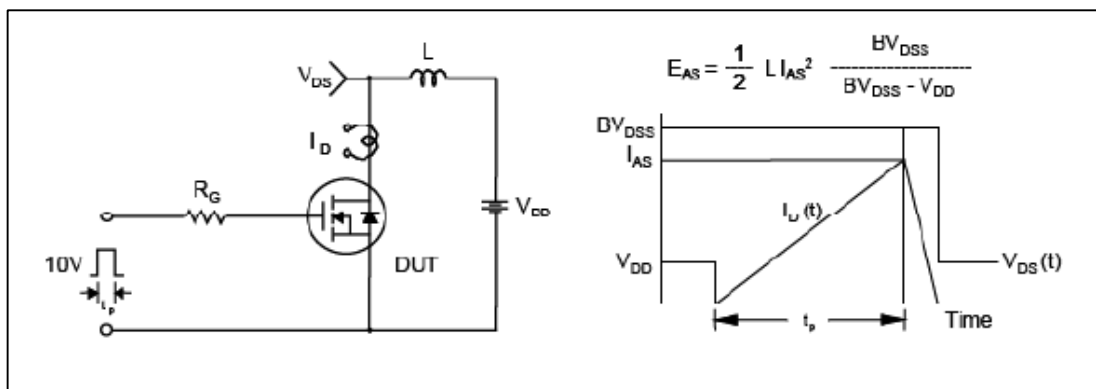

Fig.14 Unclamped Inductive Switching Test Circuit &

