

# Customer Information Sheet

DRAWING No.: M80-5T10822MI-04-331-00-000

SHEET 2 OF 2

IF IN DOUBT - ASK

Ⓒ

NOT TO SCALE

THIRD ANGLE PROJECTION

ALL DIMENSIONS IN mm

## SPECIFICATIONS:

**MATERIAL:**  
 MOULDING: GLASS FILLED PPS, UL94V-0, BLACK  
 SIGNAL CONTACT: PHOSPHOR BRONZE  
 POWER CONTACT: BRASS  
 JACKSCREW: STAINLESS STEEL

**FINISH:**  
 SIGNAL CONTACT:  
 0.75µ GOLD ON CONTACT AREA,  
 3µ 90/10 TIN/LEAD ON TAILS  
 POWER CONTACT: GOLD

**ELECTRICAL:**  
 WORKING VOLTAGE = 120V AC/DC  
 VOLTAGE PROOF = 360V AC/DC  
 INSULATION RESISTANCE = 100MΩ MIN  
**SIGNAL CONTACT:**  
 CURRENT RATING AT 25°C = 3.0A MAX  
 CURRENT RATING AT 85°C = 2.2A MAX  
 CONTACT RESISTANCE = 25 mΩ MAX  
**POWER CONTACT:**  
 CONTACT RESISTANCE 6 mΩ MAX  
 CURRENT RATING = 20A MAX

**MECHANICAL:**  
 DURABILITY = 500 OPERATIONS  
**SIGNAL CONTACT:**  
 INSERTION FORCE = 2.8N MAX  
 WITHDRAWAL FORCE = 0.2N MIN  
**POWER CONTACT:**  
 INSERTION FORCE = 5N MAX  
 WITHDRAWAL FORCE = 0.5N MIN

**ENVIRONMENTAL:**  
 TEMPERATURE RANGE = -55°C TO +125°C

**PACKING:**  
 TUBE  
 FOR COMPLETE SPECIFICATION SEE COMPONENT SPECIFICATION C005XX (LATEST ISSUE)

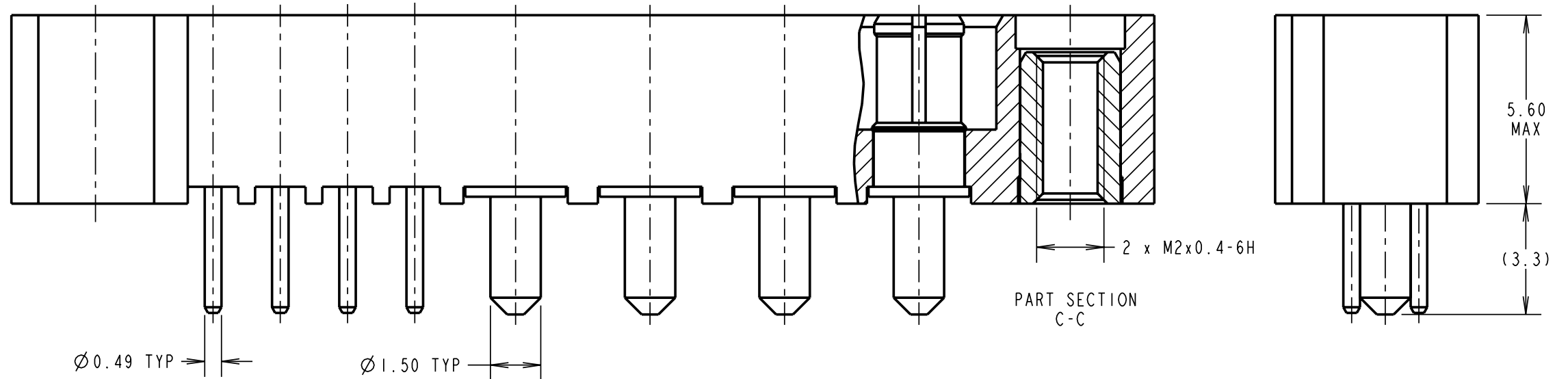
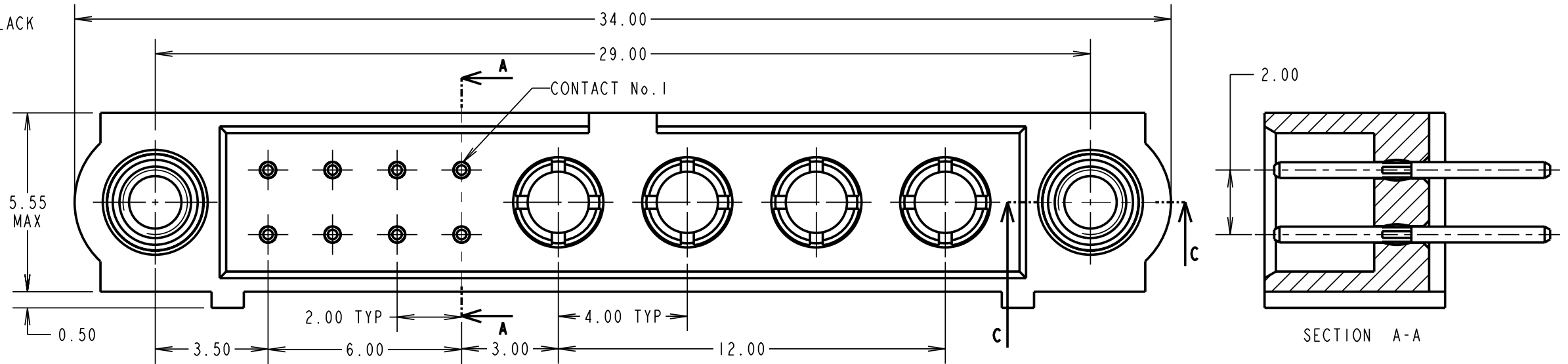

RECOMMENDED PCB LAYOUT

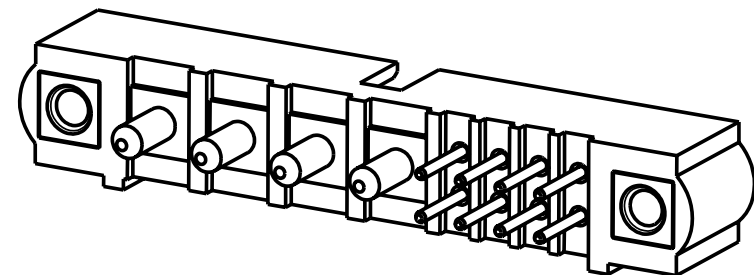
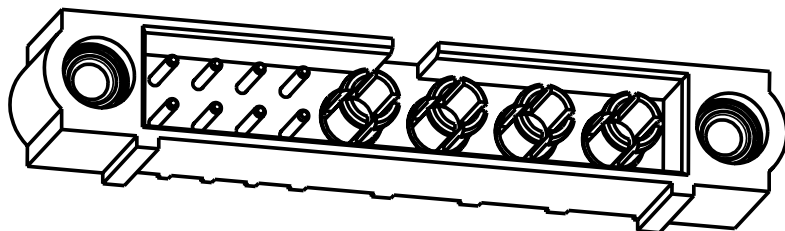
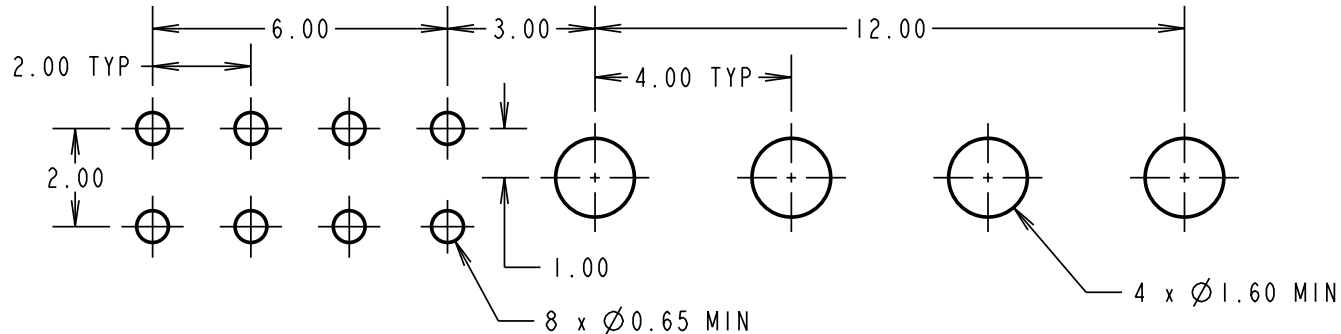

RA	A	10.03.08	----
NAME	ISS.	DATE	C/NOTE
APPROVED:		R.ADE	
CHECKED:		M.G.PLESTED	
DRAWN:		R.ADE	
CUSTOMER REF.:			
ASSEMBLY DRG:			

<b>HARWIN</b>		
HARWIN USA TEL: 603 893 5376 FAX: 603 893 5396 mis@harwin.com	HARWIN Europe (UK) TEL: 023 9231 4545 FAX: 023 9231 4590 mis@harwin.co.uk	HARWIN Asia TEL: +65 6 779 4909 FAX: +65 6 779 3868 mis@harwin.com.sg

THIS DRAWING AND ANY INFORMATION OR DESCRIPTIVE MATTER SET OUT HEREON ARE CONFIDENTIAL AND COPYRIGHT PROPERTY OF THE HARWIN GROUP AND MUST NOT BE DISCLOSED, LOANED, COPIED OR USED FOR MANUFACTURING, TENDERING OR FOR ANY OTHER PURPOSE WITHOUT THEIR WRITTEN PERMISSION.

**TOLERANCES**  
 X. = ±1mm  
 X.X = ±0.25mm  
 X.XX = ±0.10mm  
 X.XXX = ±0.01mm  
 ANGLES = ±5°  
 UNLESS STATED

**MATERIAL:**  
 SEE ABOVE  
**FINISH:**  
 SEE ABOVE  
**S/AREA:**  
 mm<sup>2</sup>

**TITLE:** JACKSCREW DATAMATE MIXED TECHNOLOGY PC TAIL MALE ASSEMBLY  
**DRAWING NUMBER:** M80-5T10822MI-04-331-00-000  
 SHT 2 OF 2