

**Huck  
Fasteners**

From Cordant Technologies

# NOSE ASSEMBLY DATA SHEET

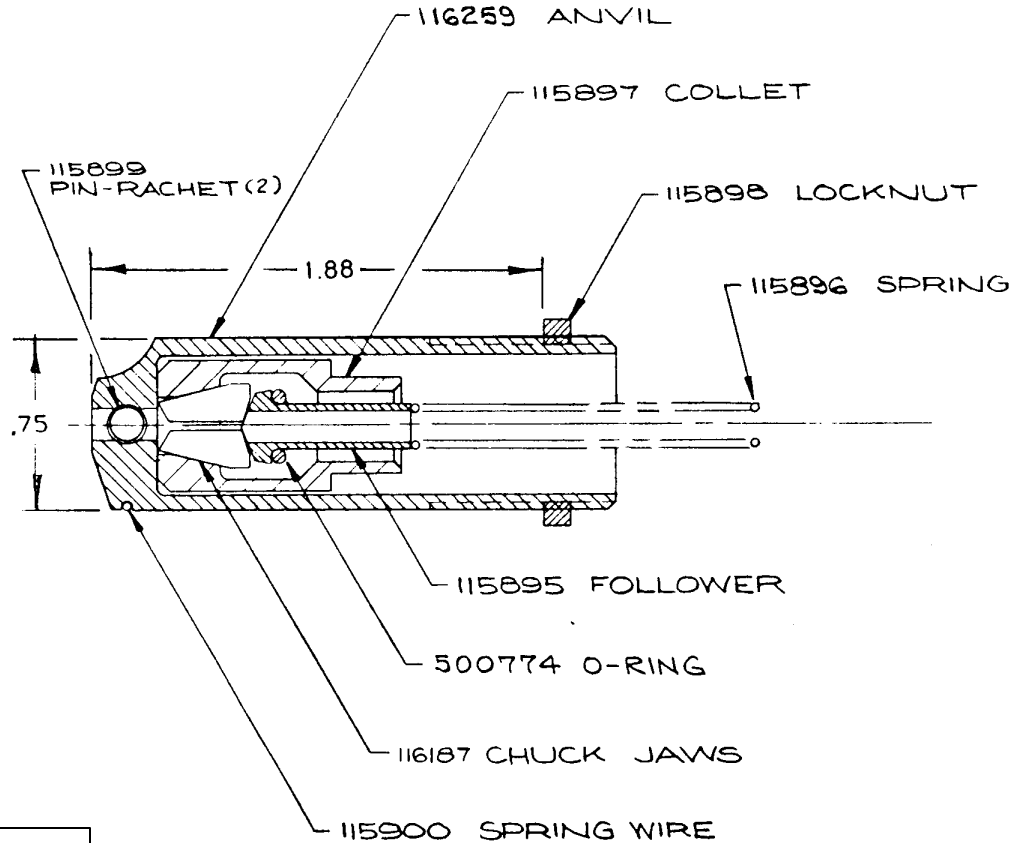

To assemble ratchet pins,  
use broken pintail in anvil.

©Huck International, Inc. 1995  
 ©Registered Trademark of Huck International, Inc., Irvine, CA  
 ™Trademark of Huck International, Inc., Irvine, CA

<b>99-1479</b>	<b>Huck International, Inc.</b> Installation System Division 1 Corporate Drive - Kingston, NY 12401	
	<b>TYPE:</b> Blind Rivet, Adjustable, Short <b>FOR:</b> HUCK-CLINCH -04, -05 & -06* <b>TOOL:</b> HK150; 227	
	<b>OTHER</b>	<b>ISSUED:</b> 9-89 <b>REVISED:</b>

\* also MAGNA-LOK® -06

**NOTE:** FOR ADAPTING NOSE ASSEMBLY TO HK150, Adapter Shaft, 202971, and Adapter Nose Tube, 202202 must be ordered separately.

## Nose Assembly Maintenance

### 1. HK150 Tool:

Prepare tool per manual, and then, unscrew nose tube from tool counterclockwise. Unscrew jaw holder from tool's puller shaft - - counterclockwise. Screw adapter shaft, 202971, onto tool's puller shaft until bottomed tighten handtight. Screw adapter nose tube, 202202, onto tool tighten - - handtight.

### 227 Tool:

Prepare tool per applicable manual.

### WARNING - - as applicable:

**Before maintenance or adjustments, tool must be disconnected from air supply. If not disconnected, severe personal injury may result.**

### 2. Tools using air source:

Air supply should have filter regulator lubricator unit with regulator set at 90 psi (620 kPa) see Caution: Cycle tool a few times and disconnect with spindle/rod **completely forward**.

**Caution:** In severe conditions, VIBRATITE can be used on collet and/or extension threads to prevent loosening or damage. Carefully follow container's directions.

### 3. Disassembly/assembly *as applicable* :

Remove parts of nose assembly for inspection and maintenance.

### Collet/extension:

Assemble parts as shown. Keep collet tipped down (to keep jaws in phase/step) and screw assembled collet onto extension/tool using 9/16 collet wrench, adjustable wrench and/or 1/4 hex key as follows:

### HK150:

Just snugup - - do not overtighten.

### 227:

Use wrench flats to tighten firmly.

**Caution:** Jaws must be in phase/step look into front of collet jaw damage may result if front of jaws are not in even alignment.

### Anvil:

Thread correct driving anvil into anvil holder - - thread lock nut onto anvil as far forward as possible. When changing anvil insert to another size, nose assembly must be readjusted - - see step 4. Before threading holder into housing of tool, see Caution above thread holder into housing of tool.

### 4. To check and adjust nose assembly:

See **Caution** in step 3. When broken pintail of fastener is inserted into driving anvil and it can be felt sliding across the jaws - - but still easily removal nose assembly is adjusted correctly. Adjustment is made by turning anvil in or out of the housing until above condition is met.

**Note:** Adjust nose assembly for each size fastener - - use correct size broken pintail.

To maintain adjustment, tighten lock nut against housing as follows:

### HK150:

Just snugup do not overtighten.

### 227:

Use wrench flats to tighten firmly.

5. **As applicable:** See **WARNING** - - connect air tool to air supply. Install enough fasteners in test plate of correct thickness with proper size holes to verify functioning of nose assembly.

### Notes

1. **To extend jaw life** : Disassemble nose assembly periodically; use a pick to clean jaw grooves.

**Caution** : Wash parts in **mineral spirits or isopropyl alcohol** only. Dry O-rings and urethane jaw assemblies **immediately** after cleaning as prolonged contact with solvent causes swelling - - dry other parts.

2. **Spare parts - - as required** : Jaws, ratchet pins; driving anvils and springs.

3. **Tool/service items - - as required** : NYLON bristle brushes 105805 (04, 05 & 06), 105806 (08); 1/4 hex key, 502445; adjustable wrench, 503044; 9/16 collet wrench, 502914; VIBRATITE, 505125.