

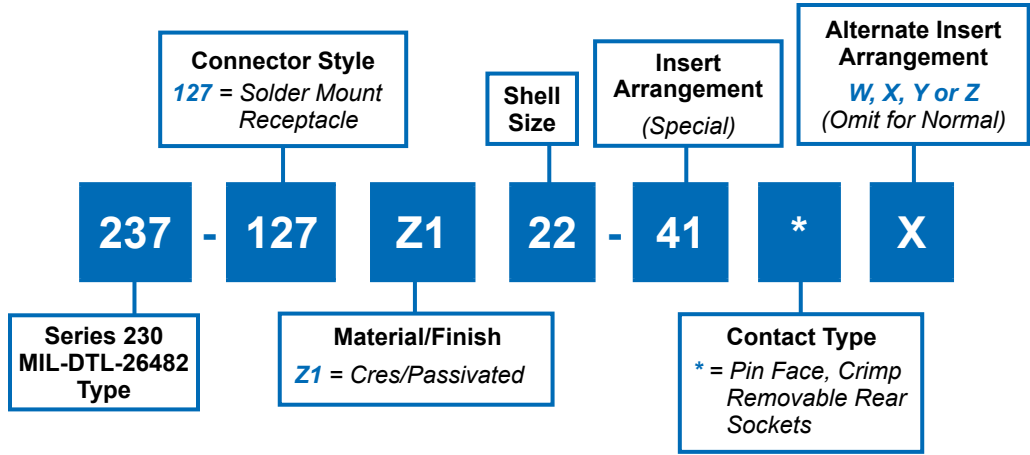

237-127
MIL-DTL-26482 Series I Type Hermetic
Bayonet Coupling Solder Flange Mount Receptacle
with Crimp Removable Rear Sockets (M39029/22 Type)

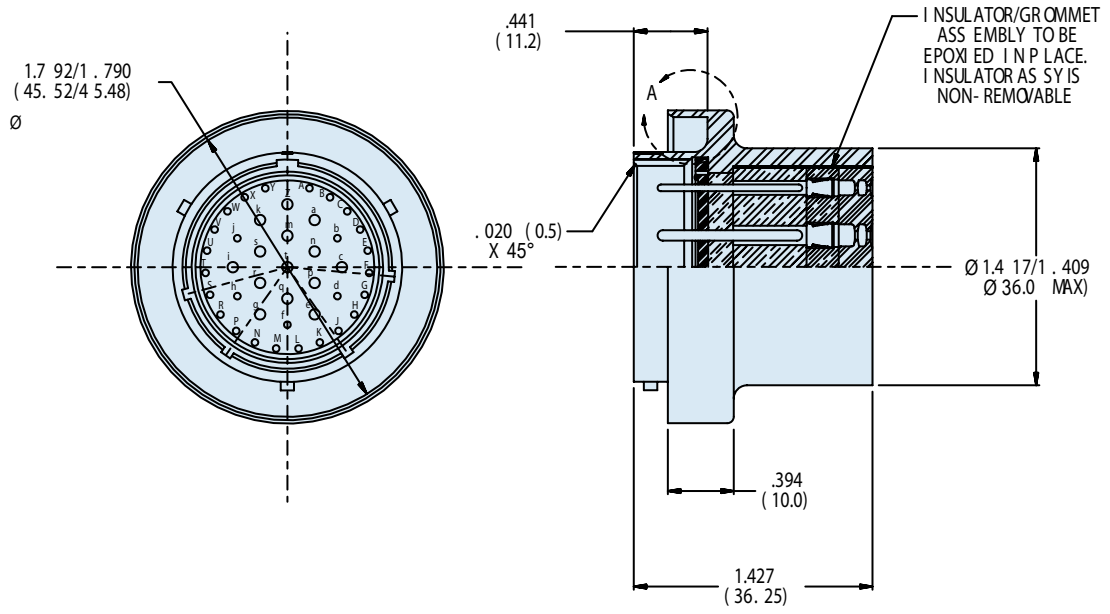

D



237-127
MIL-DTL-26482 Series I Type Hermetic
Bayonet Coupling Solder Flange Mount Receptacle
with Crimp Removable Rear Sockets (M39029/22 Type)



MIL-DTL
26482 Type

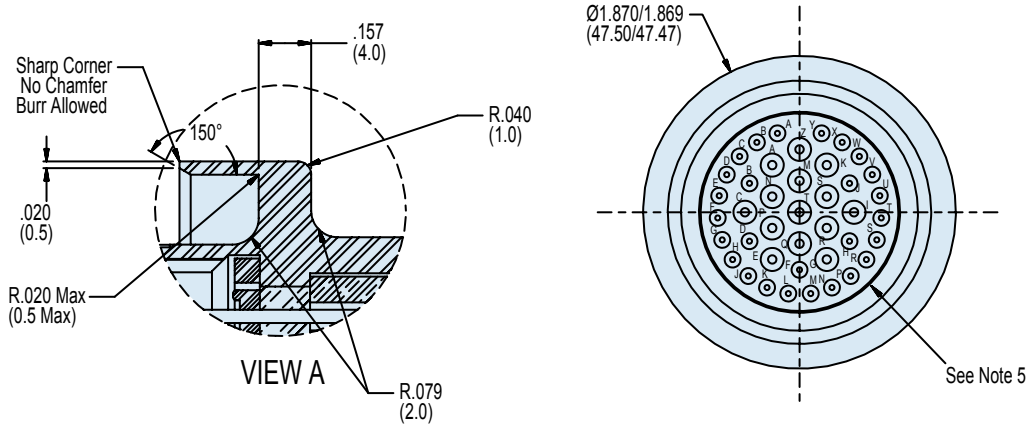

D

APPLICATION NOTES

- | | |
|---|--|
| <ol style="list-style-type: none"> 1. To be identified with manufacturer's name, part number and date code, space permitting. 2. Material/Finish:
 Shell and bayonets:
 Z1 - Cres/passivated.
 Contacts - Nickel-iron alloy/gold plated.
 Hermetic Insulator - Full glass/N.A.
 Socket insulator - Rigid dielectric/N.A.
 Seals and grommet - Silicone elastomer/N.A.
 Removable sockets - Copper alloy/gold plated.
 Socket retention clips - Copper alloy/N.A. 3. Glenair 237-127 is intermatable with any QPL manufacturers MIL-DTL-26482 plug, shell size 22, arrangement -41 per MIL-STD-1669, normal position and socket face. | <ol style="list-style-type: none"> 4. Connector is supplied with crimp-style removable contacts per M39029/22. Quantity will be sufficient to fully populate connector plus 1 extra each size. 5. Hermetic seal is centered in this flange position. 6. Performance requirements:
 Hermeticity - $<1 \times 10^{-7}$ sccHe/se @ 1 Atm. Diff.
 DWV - 1500 VAC pin-to-pin or pin-to-shell for 1 minute without breakdown (Series II requirement).
 Temperature range -40° to +100°C. 7. Metric Dimensions (mm) are indicated in parentheses. |
|---|--|