



**SF2109D**

**305.00 MHz  
SAW Filter**

- Low Insertion Loss
- 3.8 X 3.8 X 1.2 mm Surface-Mount Case
- Differential 750 Ohm IN and 900 Ohm OUT
- Complies with Directive 2002/95/EC (RoHS)



**Absolute Maximum Ratings**

Rating	Value	Units
Maximum Incident Power in Passband	+10	dBm
Max. DC voltage between any 2 terminals	30	VDC
Storage Temperature Range	-40 to +85	°C
Operating Temperature	-15 to +85	°C
Suitable for lead-free soldering - Max Soldering Profile	260°C for 30 s	

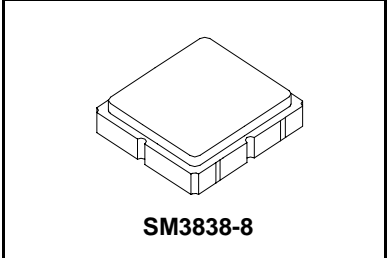

**Electrical Characteristics**

Characteristic	Sym	Notes	Min	Typ	Max	Units
Center Frequency	f <sub>C</sub>	1		305		MHz
Insertion Loss	IL	1		7	10	dB
Amplitude Ripple (p-p)	fc-4.0 to fc+4.0 MHz	1, 2		1.2	2.0	dB
Low Side Attenuation (fc-9.28 MHz)			30	35		dB
Low Side Attenuation (fc-5.78 MHz)			25	35		
High Side Attenuation (fc+5.78 MHz)			20	26		
High Side Attenuation (fc+9.28 MHz)			30	35		
Delay Ripple (p-p)	fc-4.0 to fc+4.0 MHz	1, 2, 3			300	ns
Group Delay in Passband					500	
Case Style		6	SM3838-8 3.8 x 3.8 mm Nominal Footprint			
Lid Symbolization (Y=year, WW=week, S=shift) See note 4			607 YWWS			



**CAUTION: Electrostatic Sensitive Device. Observe precautions for handling.**

**Notes:**

1. Unless noted otherwise, all specifications apply over the operating temperature range with filter soldered to the specified demonstration board with impedance matching to 50 Ω and measured with 50 Ω network analyzer.
2. Unless noted otherwise, all frequency specifications are referenced to the nominal center frequency, fc.
3. Rejection is measured as attenuation below the minimum IL point in the passband. Rejection in final user application is dependent on PCB layout and external impedance matching design. See Application Note No. 42 for details.
4. The design, manufacturing process, and specifications of this filter are subject to change.
5. Tape and Reel Standard Per ANSI / EIA 481.
6. US and international patents may apply.
7. RFM, stylized RFM logo, and RF Monolithics, Inc. are registered trademarks of RF Monolithics, Inc.
8. ©Copyright 1999, RF Monolithics Inc.

3 Mar 2006 13:02:04

CH1 S11 1 UFS  
 1: 37.277 Ω 3.1523 Ω 1.6450 nH  
 305.000 000 MHz  
 SF2109D 50 ohm demo

CH3 S22 1 UFS  
 1: 52.984 Ω 7.2871 Ω 3.8026 nH  
 305.000 000 MHz

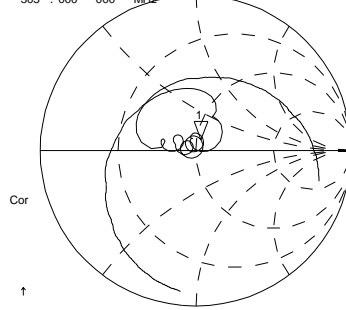
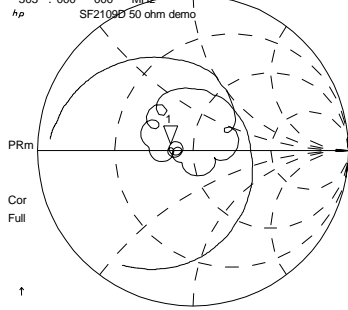

CENTR 304.000 MHz SPAN 80.000 MHz  
 CH2 S21 LOG 10 dB/ REF -7.046 dB 1: 0.0000 dB 0.000 000 MHz

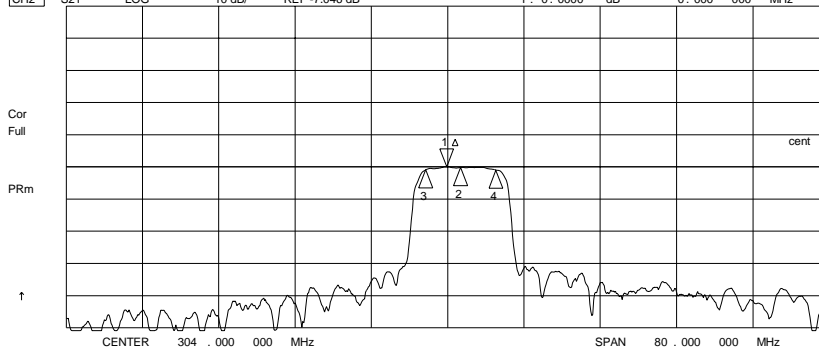

CH2 Markers  
 Max Δ REF=1  
 BW: 7.378194 MHz  
 cent: 305.380082 MHz  
 Q: 41.390  
 loss: -7.0214 dB

3 Mar 2006 13:05:41

CH1 S21 DEL 100 ns/ REF 500 ns 3: 22.793 ns -8.000 000 MHz

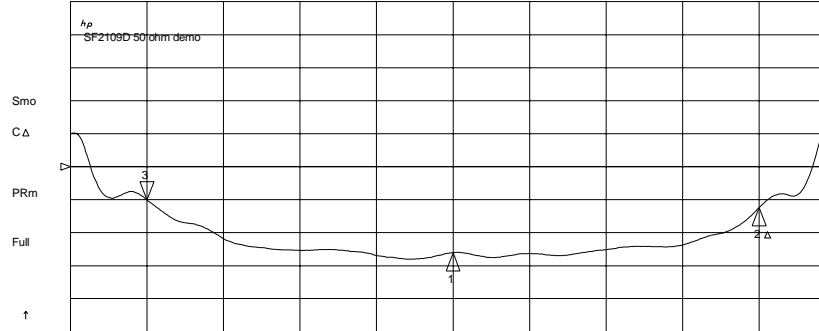

CH1 Markers  
 Δ REF=2  
 mean: 262.50 ns  
 s. dev: 39.617 ns  
 p-p: 179.82 ns

CH2 S21 LOG 1 dB/ REF -7.046 dB 3: -.37930 dB -8.000 000 MHz

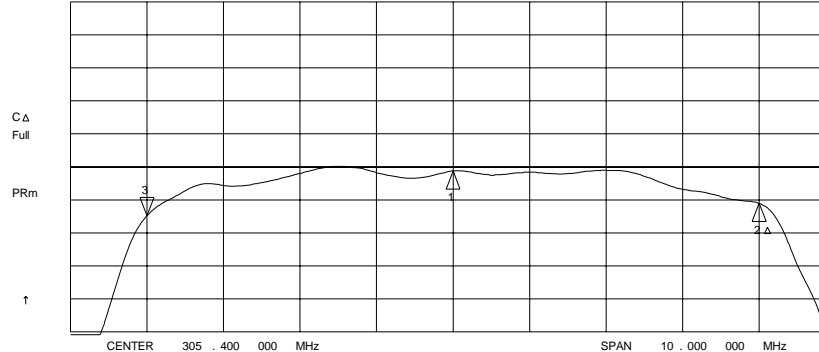

CH2 Markers  
 Δ REF=2  
 mean: -7.4435 dB  
 s. dev: .32180 dB  
 p-p: 1.4982 dB

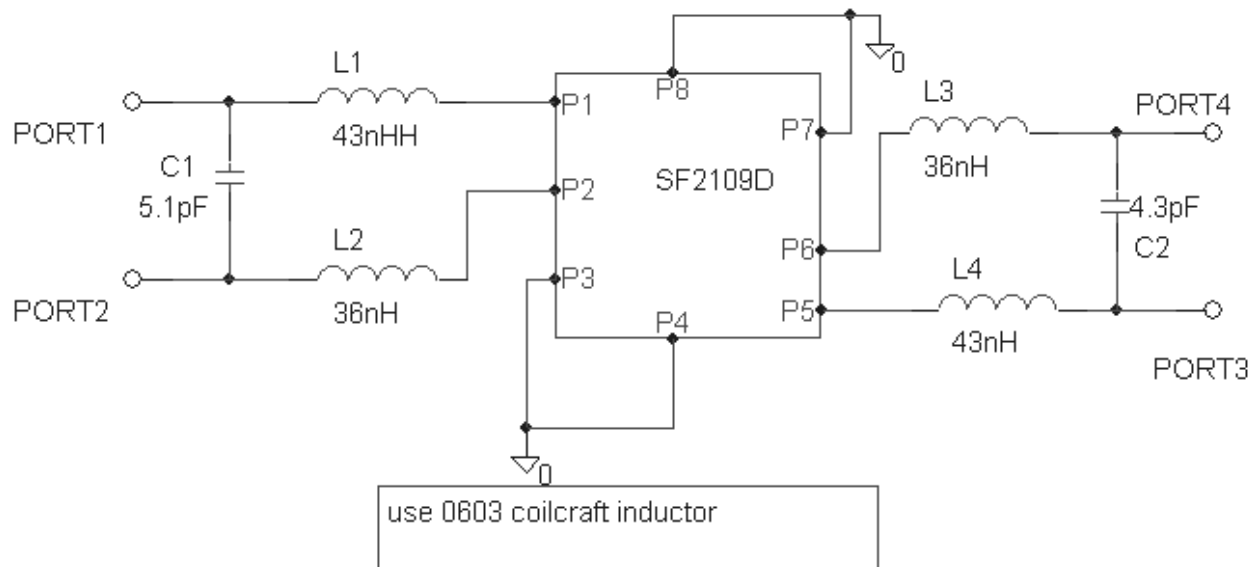
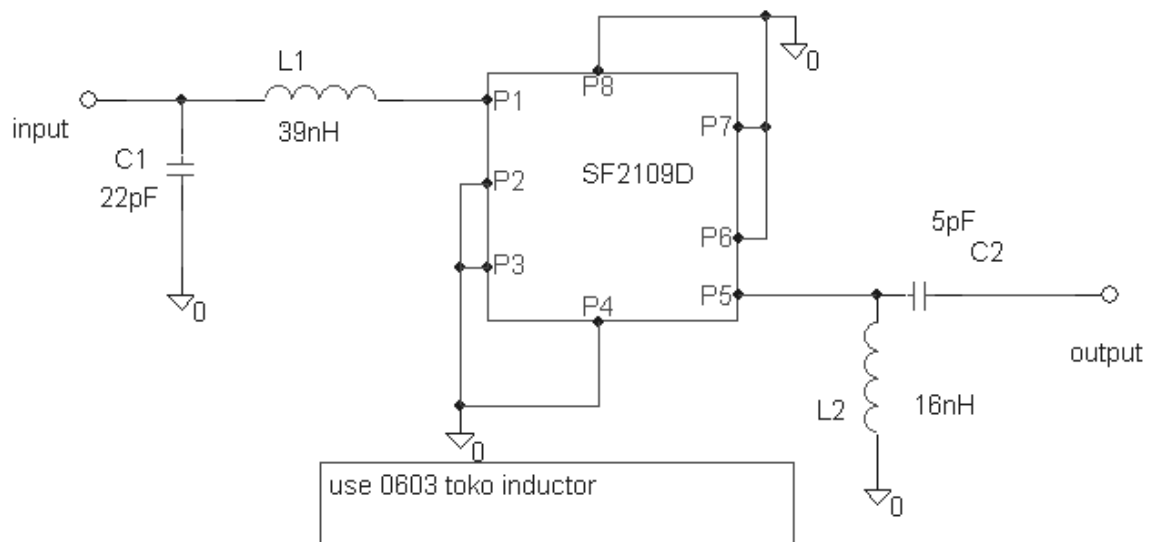

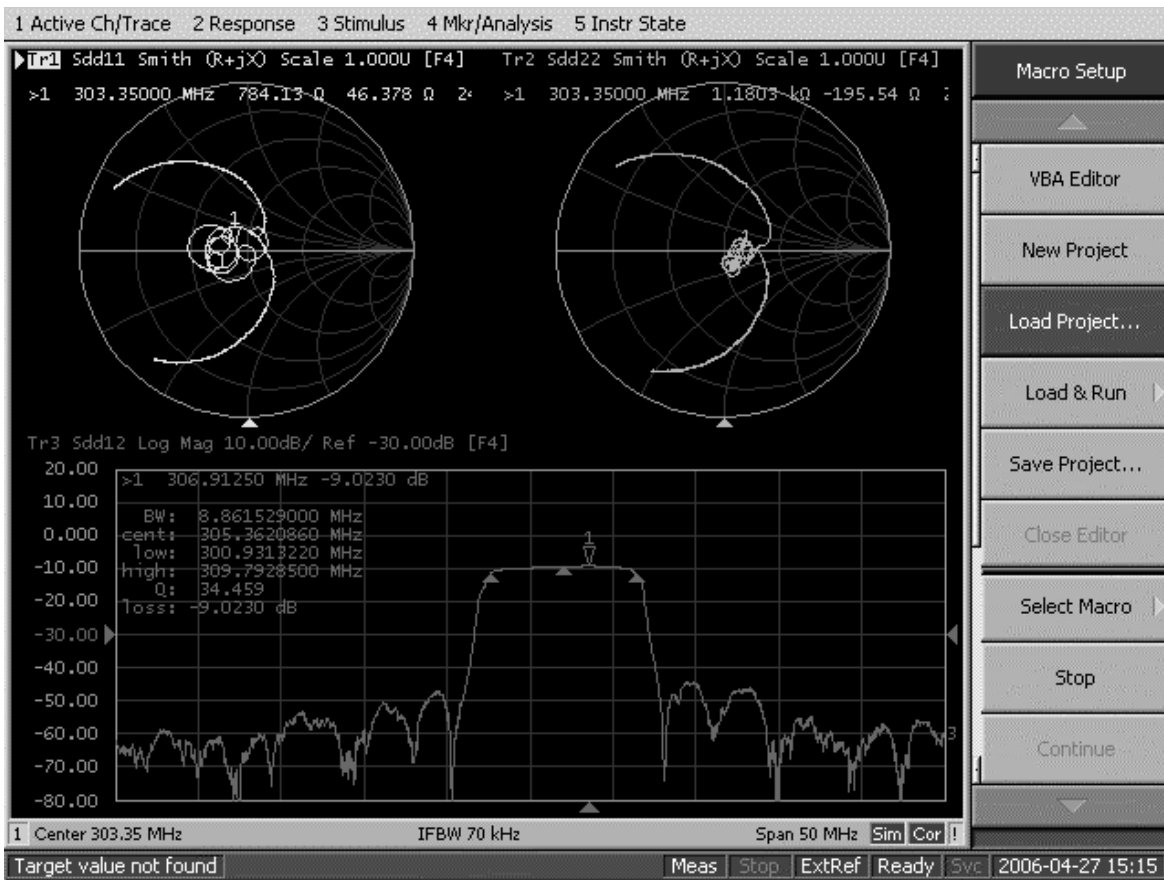

Macro Setup

VBA Editor

New Project

Load Project...

Load & Run ▶

Save Project...

Close Editor

Select Macro ▶

Stop

Continue

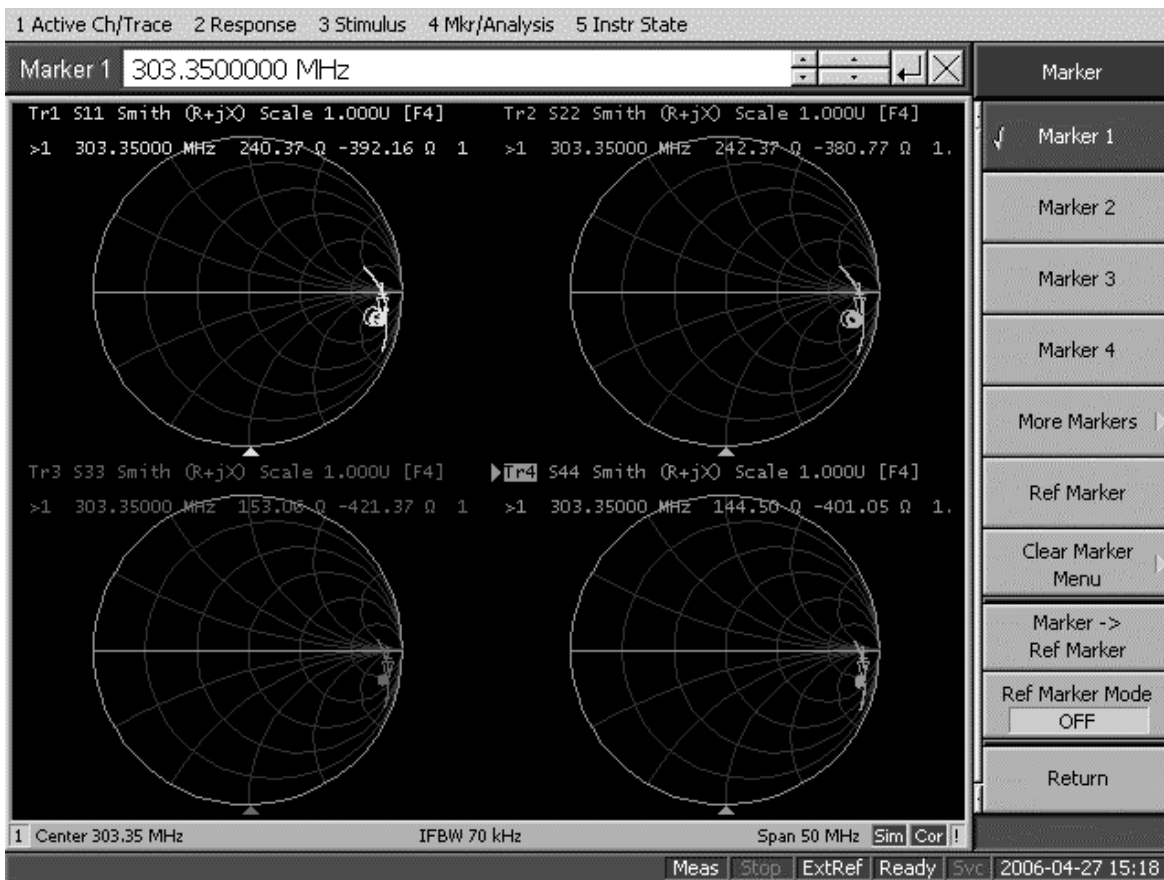

Marker

Marker 1

Marker 2

Marker 3

Marker 4

More Markers ▶

Ref Marker

Clear Marker Menu ▶

Marker -> Ref Marker

Ref Marker Mode OFF

Return

# SM3838-8 Case

## 8-Terminal Ceramic Surface-Mount Case

### 3.8 X 3.8 mm Nominal Footprint

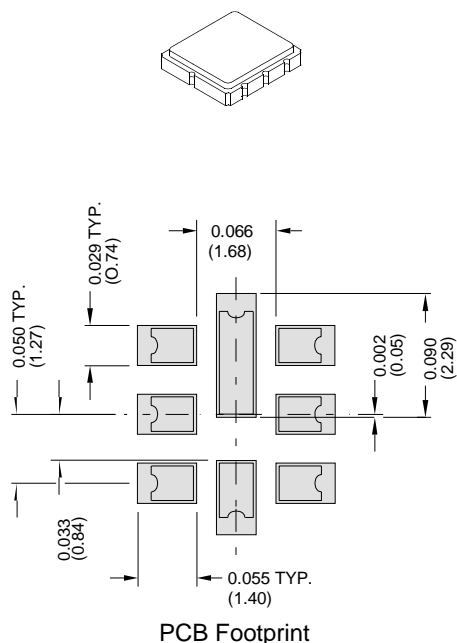

Case Dimensions						
Dimension	mm			Inches		
	Min	Nom	Max	Min	Nom	Max
A	3.6	3.8	4.0	0.142	0.150	0.157
B	3.6	3.8	4.0	0.142	0.150	0.157
C	1.05	1.20	1.35	0.041	0.047	0.053
D	0.95	1.10	1.25	0.037	0.043	0.049
E	0.90	1.00	1.10	0.035	0.040	0.043
F	0.50	0.60	0.70	0.020	0.024	0.028
G	2.39	2.54	2.69	0.090	0.100	0.110
H	1.40	1.75	2.05	0.055	0.069	0.080

Electrical Connections		
	Connection	Terminals
Port 1	Differential Input	1, 2
Port 2	Differential Output	5, 6
	Ground	All Others
<b>Single Ended Operation</b>		<b>Return is Ground</b>
<b>Differential Operation</b>		<b>Return is Hot</b>
Dot Indicates Pin 1		

Materials	
Solder Pad Termination	Au plating 30 - 60 ulnches (76.2-152 uM) over 80-200 ulnches (203-508 uM) Ni.
Lid	Fe-Ni-Co Alloy Electroless Nickel Plate (8-11% Phosphorus) 100-200 ulnches Thick
Body	Al <sub>2</sub> O <sub>3</sub> Ceramic
Pb Free	

TOP VIEW

BOTTOM VIEW

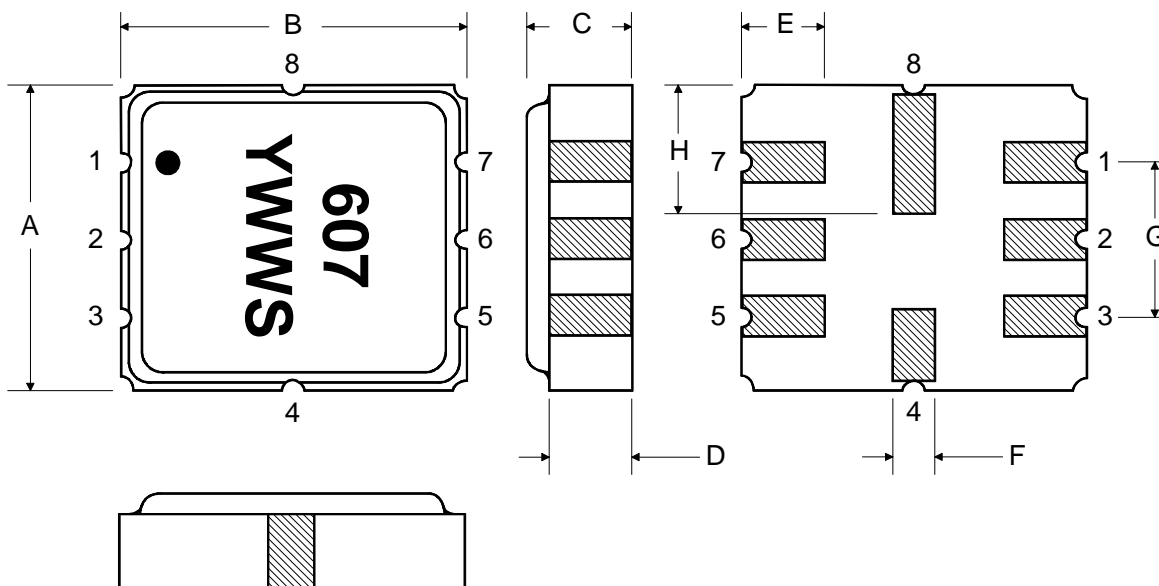

## Tape and Reel Specifications

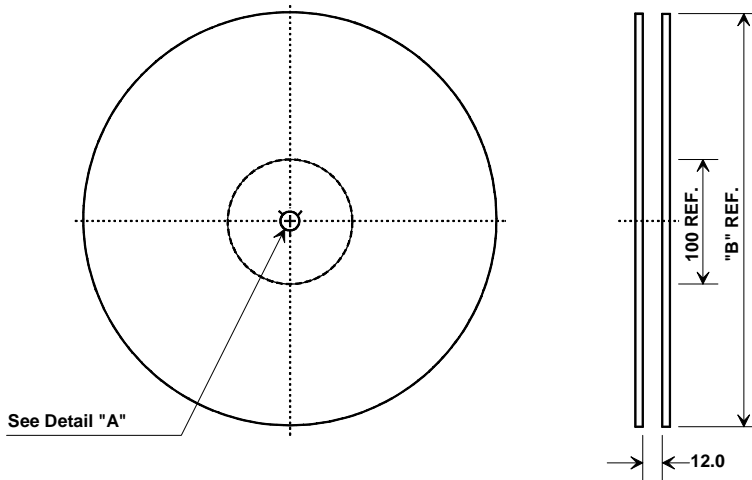

"B"		Quantity Per Reel
Inches	millimeters	
7	178	500
13	330	3000

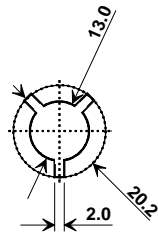

### COMPONENT ORIENTATION and DIMENSIONS

Carrier Tape Dimensions	
<b>Ao</b>	4.25 mm
<b>Bo</b>	4.25 mm
<b>Ko</b>	1.30 mm
<b>Pitch</b>	8.0 mm
<b>W</b>	12.0 mm

