

System LED Drivers for Mobile Phones

Charge Pump type for Flash



BD7700GU

No.11041EAT19

●Description

BD7700GU is a maximum of 300mA LED flash (three-channel total) driver IC. Flash mode and torch mode are controllable by two external control signals. The flash mode timer ability for a maximum of 1s is carried, and management of flash lighting time is easy and safe.

●Features

- 1) Current regulation for LED
- 2) 3ch High side current Driver
- 3) Flash LED High side Current driver (Max 100mA@1ch)
- 4) Torch LED High side Current driver (Max 20mA@1ch)
- 5) Indicate LED High side Current driver (Max 1mA)
- 6) High efficiency up to 80%
- 7) 2port control Flash and Torch and Indicate mode
- 8) Charge pump step-up DC/DC converter (Max 300mA) Three charge pump mode (×1, ×1.5, ×2.0)
- 9) Automatically transition to each mode
- 10) Over-voltage protection / In rush current prevention (soft start) / Over current limiter
- 11) Under Voltage Lockout threshold / Thermal shutdown
- 12) Small and thin CSP package

●Applications

Flash and torch of camera for mobile phone

●Absolute Maximum Ratings (Ta=25°C)

Parameter	Symbol	Ratings	Unit
Maximum applied voltage	VMAX	7	V
Input voltage	Vdin	GND-0.3 ~ VBAT+0.3	V
Power dissipation	Pd	1062.5 (Note1)	mW
Operating temperature range	Topr	-30 ~ +85	°C
Storage temperature range	Tstg	-55 ~ +150	°C

(Note1) The measurement value, which was mounted on the PCB by ROHM.
Temperature deleting : 8.5mW/°C from Ta>25°C

●Operating conditions (Ta=-30 ~ 85°C)

Parameter	Symbol	Ratings	Unit
Battery Power Supply voltage	VBAT	2.7 - 5.5	V

●Electrical Characteristics

(Unless otherwise noted, Ta = 25°C, VBAT=3.6V)

Parameter	Symbol	Limits			Units	Condition
		Min.	Typ.	Max.		
Logic control terminal						
Low threshold voltage	VthL2	-	-	0.4	V	CNT0 and CNT1 port
High threshold voltage	VthH2	1.2	-	-	V	CNT0 and CNT1 port
High level Input current	IinH2	-	18.3	33	μA	CNT0 or CNT1 = 5.5V
Low level Input current	IinL2	-1	0	-	μA	CNT0 or CNT1 = 0V
DC/DC Converter						
Quiescent Current	Iq	-	0.1	1.0	μA	CNT0 and CNT1 = '0'
Flash Current Accuracy	Iflash	-15	0	15	%	100mA
Torch Current Accuracy	Itorch	-15	0	15	%	20mA
Indicate Current Accuracy	Iind	-30	0	30	%	1mA,LED2 Terminal
Current Consumption 1	Idd1	-	1.0	2.0	mA	X1.0 mode, LED current = 0mA
Current Consumption 2	Idd2	-	6.0	9.0	mA	X1.5 mode, LED current = 0mA
Current Consumption 3	Idd3	-	9.0	12.0	mA	X2.0 mode, LED current = 0mA
ISET Voltage	Viset	0.5	0.6	0.7	V	
Switching frequency	Fsw	1.0	1.25	1.5	MHz	
Sat Voltage	Vsat	150	250	350	mV	VOUT-LED Voltage(VLED=3V)
Over voltage protection	Vovp	5.5	-	-	V	VOUT Limit
Under voltage lock-out	Vuvlo	1.8	2.0	2.2	V	UVLO Detect Voltage
Start up time	Tstart	-	-	3	ms	Stand by → Torch,Flash,Indicate

●Package Outline

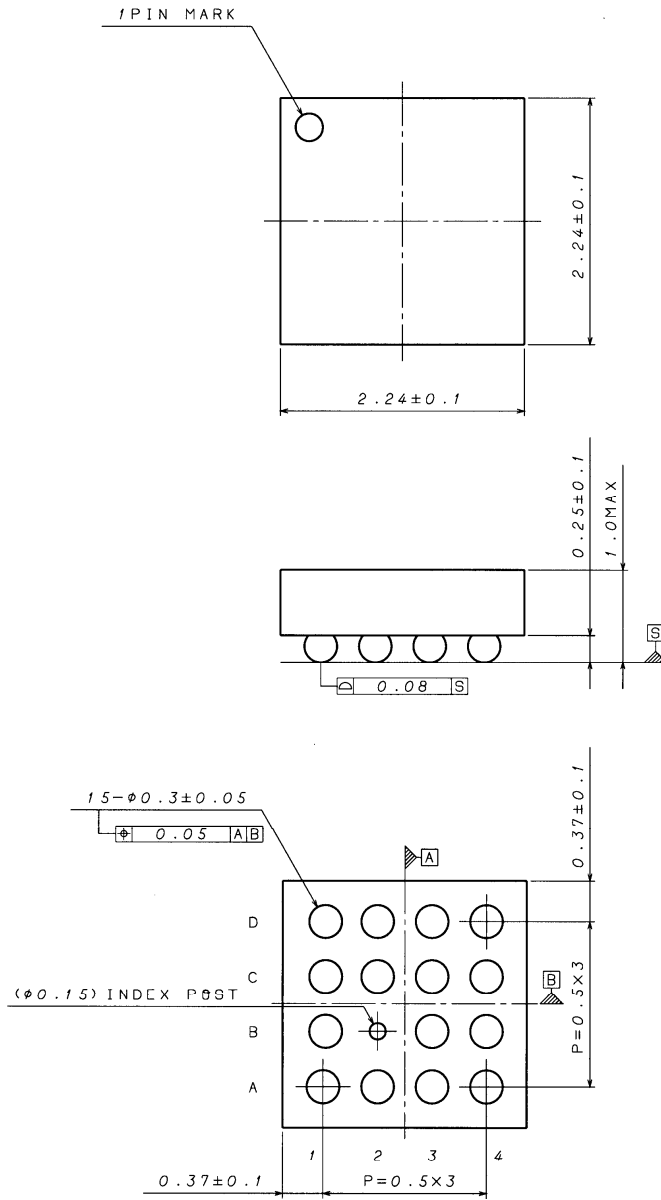

Drawing No: EX901-5013

(UNIT: mm)

Fig.1. Package outline

● Terminals

No.	Pin Name	In/Out	Type	ESD Diode		Functions
				for Power	for GND	
C4	VBAT	-	A	-	GND	Battery power supply pin
A2	VBAT	-	A	-	GND	Battery power supply pin
C2	CNT0	In	G	VBAT	GND	LED control input '1': On, '0': Off
C3	CNT1	In	G	VBAT	GND	LED control input '1': On, '0': Off
B4	VOUT	Out	A	-	GND	Output Voltage
A4	LED1	Out	D	-	GND	Current drive out for Torch,Flash
A3	LED2	Out	D	-	GND	Current drive out for Torch,Flash,Indicate
B3	LED3	Out	D	-	GND	Current drive out for Torch,Flash
B1	ISET	In	B	VBAT	GND	Resistor connection for LED current setting
D4	C1P	In/Out	B	VBAT	GND	Positive terminal of transfer capacitor 1
D1	C1N	In/Out	A	-	GND	Negative terminal of transfer capacitor 1
D3	C2P	In/Out	B	VBAT	GND	Positive terminal of transfer capacitor 2
D2	C2N	In/Out	A	-	GND	Negative terminal of transfer capacitor 2
C1	GND	-	F	VBAT	-	Ground pin
A1	GND	-	F	VBAT	-	Ground pin

Total : 15 Pin

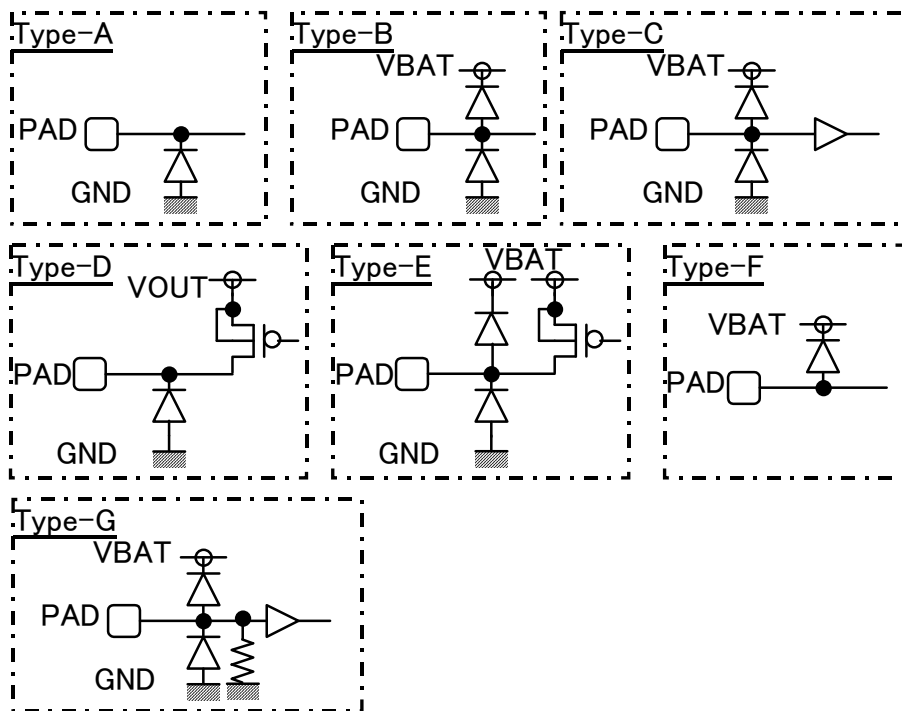

●Functional Description

1. "FLASH" and "TORCH" and "Indicate" pin control

"FLASH" and "TORCH" select

"FLASH" and "TORCH" is selected by "CNT0" and "CNT1" pin.

Status is as follows.

CNT1	CNT0	Status
0	0	All LED OFF
0	1	Indicate
1	0	TORCH
1	1	FLASH

"FLASH" control

"FLASH" status turns "High", Flash LED Current is occurred, and "FLASH" status turns "Low", Flash LED Current is OFF.

"FLASH" status is set by CNT0 pin = "1" and CNT1 pin = "1".

Flash term is maximum 1s by internal timer.

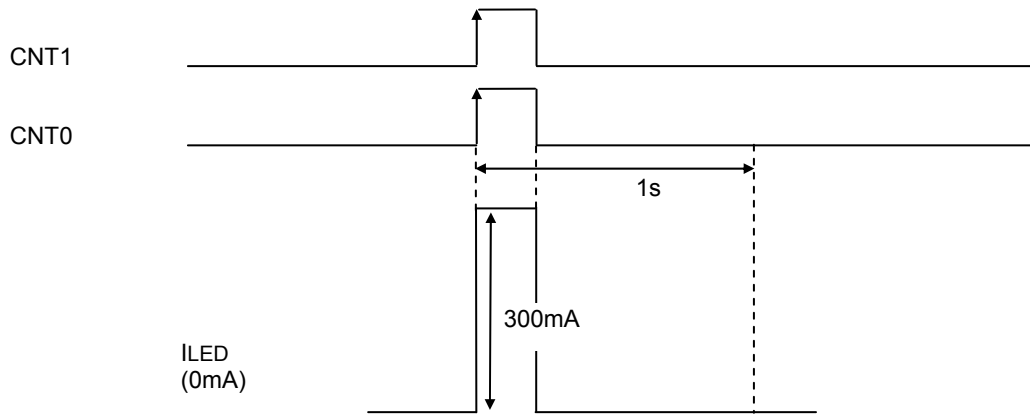

Fig-4. FLASH control and LED Current

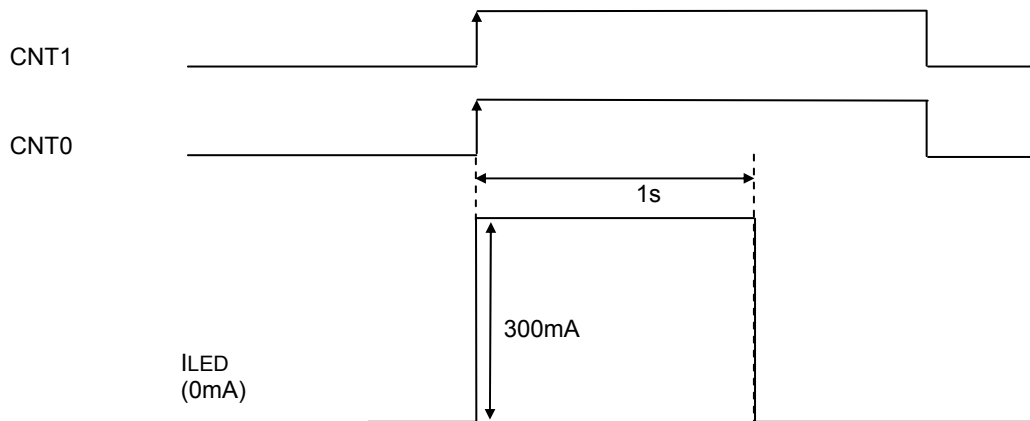

Fig-5. FLASH control and LED Current (with Timer Limit)

“TORCH” control

“TORCH” status turns “High”, LED Current is occurred at 60mA(Torch Mode, 3 channel total), and “TORCH” status turns “Low”, LED Current is OFF.

“TORCH” status is set by CNT0 pin = “0” and CNT1 pin = “1”.

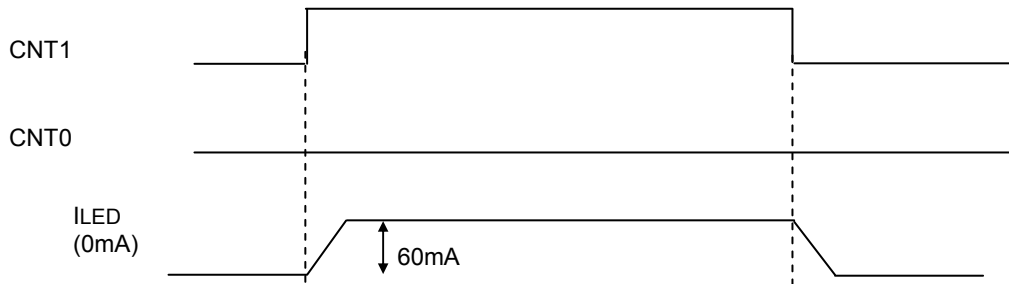

Fig-6. TORCH control and LED Current

“Indicate” control

“Indicate” status turns “High”, LED2 Current is occurred at 1 mA.LED1 and LED3 Current is occurred at 0mA.Indicate” status turns “Low”, LED Current is OFF.

“Indicate” status is set by CNT0 pin = “1” and CNT1 pin = “0”.

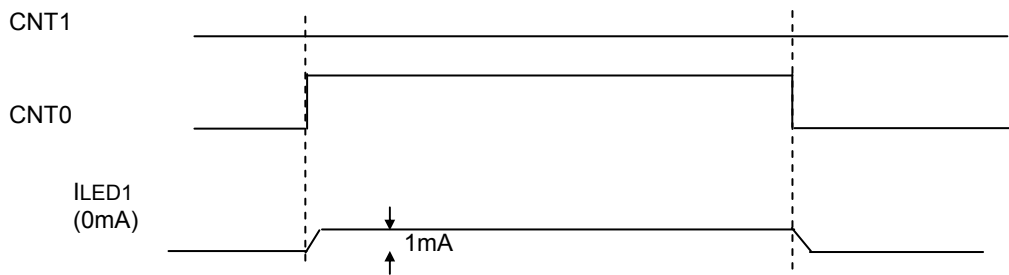

Fig-7. Indicate LED control and Indicate LED Current

2. LED Current control by “Rset”

The setting of Rset controls LED current, and following equation shows the LED current(@1ch).

$$I_{LED} = 1200 / R_{set} \quad (\text{Flash})$$

$$I_{LED} = 240 / R_{set} \quad (\text{Torch})$$

$$I_{LED} = 12 / R_{set} \quad (\text{Indicate})$$

Then, follows Table shows the LED current(@1ch) for some Rset settings.(Typical)

Rset	120kΩ	62kΩ	30kΩ	20kΩ	15kΩ	12kΩ
I _{LED} (FLASH)	10mA	20mA	40mA	60mA	80mA	100mA
I _{LED} (TORCH)	2mA	4mA	8mA	12mA	16mA	20mA
I _{LED} (Indicate)	0.1mA	0.2mA	0.4mA	0.6mA	0.8mA	1mA

Ratio of Flash and Torch current deviates from 5:1 by RSET value in light-load of LED current.

3. Charge pump mode transition

The charge pump mode is automatically and optimally changed.

(From x1 mode to x1.5 mode)

(From x1.5 mode to x2.0 mode)

Power supply voltage goes down and this IC can't keep constant LED current, then the mode transition will start.

(From x1.5 mode to x1 mode)

(From x2.0 mode to x1.5 mode)

Power supply voltage goes up and the detection of VOUT and VBAT is worked, then the mode transition will start.

4. Over voltage and current protection

This IC has VOUT over voltage and current protection for VOUT.

Even if LED pins are open, VOUT voltage is kept below limit voltage.

Even if VOUT pin is short to GND, current limiter works and restrains VBAT current.

5. UVLO function

This IC is shut down when VBAT is under Vuvlo voltage.

This IC automatically return initial operation when VBAT is up to Vuvlo voltage, and IC will return to normal operation.

6. Thermal shutdown function

This IC has a thermal shut down function.

It works above 175°C, and under the situation, IC will change the status from active to inactive.

To become under 175°C, IC will return to normal operation.

● Selection of external parts

Recommended external parts are as shown below.

When to use other parts than these, select the following equivalent parts.

• Capacitor

Value	Manufacturer	Product number	Size			Temp. Chara.	Rated Voltage
			Vertical size	Horizontal size	Height		
【 CIN 】							
2.2μF	MURATA	GRM155B30J225ME	1.0	0.5	0.5	B	6.3V
【 COUT 】							
4.7μF	MURATA	GRM188B31A475KE15D	1.6	0.8	0.8	B	10V
【 C1, C2 】							
2.2μF	MURATA	GRM155B30J225ME	1.0	0.5	0.5	B	6.3V

[LED specification]

This IC targets to drive high power LED. Available VF(Forward voltage) range of LED is as follows.

	Typ	Max
VF	3.4V	5V

at 100mA/1ch , Ta=25°C

Note) LED VF range has Temperature characteristics. It is necessary to choose suitable LED characteristics at LED Current setting.

Available LED terminal Voltage range is changed by LED current.

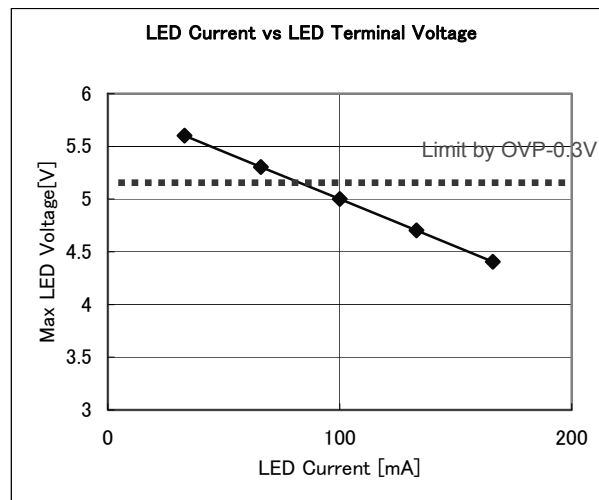

$R_{on}(x2.0)=1.76\Omega$

●Notes for use

- (1) Absolute Maximum Ratings
An excess in the absolute maximum ratings, such as supply voltage, temperature range of operating conditions, etc., can break down devices, thus making impossible to identify breaking mode such as a short circuit or an open circuit. If any special mode exceeding the absolute maximum ratings is assumed, consideration should be given to take physical safety measures including the use of fuses, etc.
- (2) Operating conditions
These conditions represent a range within which characteristics can be provided approximately as expected. The electrical characteristics are guaranteed under the conditions of each parameter.
- (3) Reverse connection of power supply connector
The reverse connection of power supply connector can break down ICs. Take protective measures against the breakdown due to the reverse connection, such as mounting an external diode between the power supply and the IC's power supply terminal.
- (4) Power supply line
Design PCB pattern to provide low impedance for the wiring between the power supply and the GND lines. In this regard, for the digital block power supply and the analog block power supply, even though these power supplies has the same level of potential, separate the power supply pattern for the digital block from that for the analog block, thus suppressing the diffraction of digital noises to the analog block power supply resulting from impedance common to the wiring patterns. For the GND line, give consideration to design the patterns in a similar manner.
Furthermore, for all power supply terminals to ICs, mount a capacitor between the power supply and the GND terminal. At the same time, in order to use an electrolytic capacitor, thoroughly check to be sure the characteristics of the capacitor to be used present no problem including the occurrence of capacity dropout at a low temperature, thus determining the constant.
- (5) GND voltage
Make setting of the potential of the GND terminal so that it will be maintained at the minimum in any operating state. Furthermore, check to be sure no terminals are at a potential lower than the GND voltage including an actual electric transient.
- (6) Short circuit between terminals and erroneous mounting
In order to mount ICs on a set PCB, pay thorough attention to the direction and offset of the ICs. Erroneous mounting can break down the ICs. Furthermore, if a short circuit occurs due to foreign matters entering between terminals or between the terminal and the power supply or the GND terminal, the ICs can break down.
- (7) Operation in strong electromagnetic field
Be noted that using ICs in the strong electromagnetic field can malfunction them.
- (8) Inspection with set PCB
On the inspection with the set PCB, if a capacitor is connected to a low-impedance IC terminal, the IC can suffer stress. Therefore, be sure to discharge from the set PCB by each process. Furthermore, in order to mount or dismount the set PCB to/from the jig for the inspection process, be sure to turn OFF the power supply and then mount the set PCB to the jig. After the completion of the inspection, be sure to turn OFF the power supply and then dismount it from the jig. In addition, for protection against static electricity, establish a ground for the assembly process and pay thorough attention to the transportation and the storage of the set PCB.
- (9) Input terminals
In terms of the construction of IC, parasitic elements are inevitably formed in relation to potential. The operation of the parasitic element can cause interference with circuit operation, thus resulting in a malfunction and then breakdown of the input terminal. Therefore, pay thorough attention not to handle the input terminals, such as to apply to the input terminals a voltage lower than the GND respectively, so that any parasitic element will operate. Furthermore, do not apply a voltage to the input terminals when no power supply voltage is applied to the IC. In addition, even if the power supply voltage is applied, apply to the input terminals a voltage lower than the power supply voltage or within the guaranteed value of electrical characteristics.
- (10) Ground wiring pattern
If small-signal GND and large-current GND are provided, It will be recommended to separate the large-current GND pattern from the small-signal GND pattern and establish a single ground at the reference point of the set PCB so that resistance to the wiring pattern and voltage fluctuations due to a large current will cause no fluctuations in voltages of the small-signal GND. Pay attention not to cause fluctuations in the GND wiring pattern of external parts as well.
- (11) External capacitor
In order to use a ceramic capacitor as the external capacitor, determine the constant with consideration given to a degradation in the nominal capacitance due to DC bias and changes in the capacitance due to temperature, etc.

(12) Not connecting input terminals

In terms of extremely high impedance of CMOS gate, to open the input terminals causes unstable state. Unstable state occurs from the inside gate voltage of p-channel or n-channel transistor into active. As a result, power supply current may increase. And unstable state can also cause unexpected operation of IC. So unless otherwise specified, input terminals not being used should be connected to the power supply or GND line.

(13) Thermal shutdown circuit (TSD)

When junction temperatures become setting temperature or higher, the thermal shutdown circuit operates and turns a switch OFF. The thermal shutdown circuit, which is aimed at isolating the LSI from thermal runaway as much as possible, is not aimed at the protection or guarantee of the LSI. Therefore, do not continuously use the LSI with this circuit operating or use the LSI assuming its operation.

(14) Thermal design

Perform thermal design in which there are adequate margins by taking into account the permissible dissipation (Pd) in actual states of use.

●Ordering part number

B	D
---	---

Part No.

7	7	0	0
---	---	---	---

Part No.
7700

G	U
---	---

Package
GU : VCSP85H2

E	2
---	---

Packaging and forming specification
E2: Embossed tape and reel

VCSP85H2 (BD7700GU)

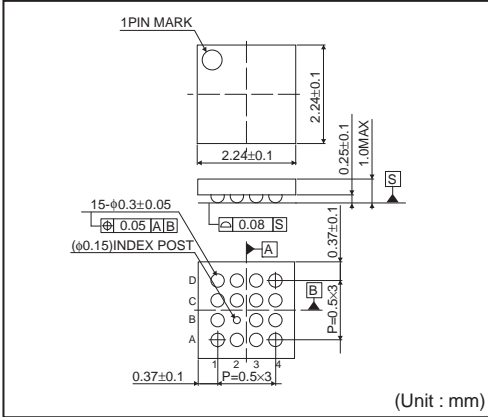

<Tape and Reel information>

Tape	Embossed carrier tape
Quantity	3000pcs
Direction of feed	E2 (The direction is the 1pin of product is at the upper left when you hold reel on the left hand and you pull out the tape on the right hand)

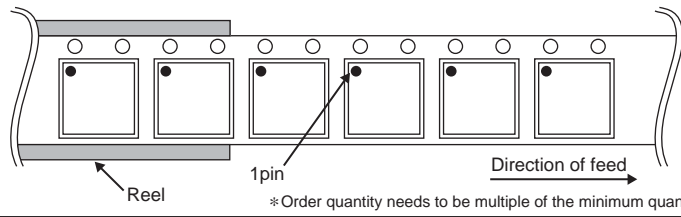

Notes

No copying or reproduction of this document, in part or in whole, is permitted without the consent of ROHM Co.,Ltd.

The content specified herein is subject to change for improvement without notice.

The content specified herein is for the purpose of introducing ROHM's products (hereinafter "Products"). If you wish to use any such Product, please be sure to refer to the specifications, which can be obtained from ROHM upon request.

Examples of application circuits, circuit constants and any other information contained herein illustrate the standard usage and operations of the Products. The peripheral conditions must be taken into account when designing circuits for mass production.

Great care was taken in ensuring the accuracy of the information specified in this document. However, should you incur any damage arising from any inaccuracy or misprint of such information, ROHM shall bear no responsibility for such damage.

The technical information specified herein is intended only to show the typical functions of and examples of application circuits for the Products. ROHM does not grant you, explicitly or implicitly, any license to use or exercise intellectual property or other rights held by ROHM and other parties. ROHM shall bear no responsibility whatsoever for any dispute arising from the use of such technical information.

The Products specified in this document are intended to be used with general-use electronic equipment or devices (such as audio visual equipment, office-automation equipment, communication devices, electronic appliances and amusement devices).

The Products specified in this document are not designed to be radiation tolerant.

While ROHM always makes efforts to enhance the quality and reliability of its Products, a Product may fail or malfunction for a variety of reasons.

Please be sure to implement in your equipment using the Products safety measures to guard against the possibility of physical injury, fire or any other damage caused in the event of the failure of any Product, such as derating, redundancy, fire control and fail-safe designs. ROHM shall bear no responsibility whatsoever for your use of any Product outside of the prescribed scope or not in accordance with the instruction manual.

The Products are not designed or manufactured to be used with any equipment, device or system which requires an extremely high level of reliability the failure or malfunction of which may result in a direct threat to human life or create a risk of human injury (such as a medical instrument, transportation equipment, aerospace machinery, nuclear-reactor controller, fuel-controller or other safety device). ROHM shall bear no responsibility in any way for use of any of the Products for the above special purposes. If a Product is intended to be used for any such special purpose, please contact a ROHM sales representative before purchasing.

If you intend to export or ship overseas any Product or technology specified herein that may be controlled under the Foreign Exchange and the Foreign Trade Law, you will be required to obtain a license or permit under the Law.



Thank you for your accessing to ROHM product informations.
More detail product informations and catalogs are available, please contact us.

ROHM Customer Support System

<http://www.rohm.com/contact/>