

DATA SHEET

AA113-310, AA113-310LF: GaAs IC 6-Bit Digital Attenuator with Driver 0.5 dB LSB Positive Control LF–1 GHz

Features

- Attenuation 0.5 dB steps to 31.5 dB with high accuracy
- Single positive control for each bit
- Low DC power consumption
- CMOS integrated silicon driver
- Designed for use at IF frequencies
- Available lead (Pb)-free and RoHS-compliant MSL-1 @ 260 °C per JEDEC J-STD-020

Pin Out

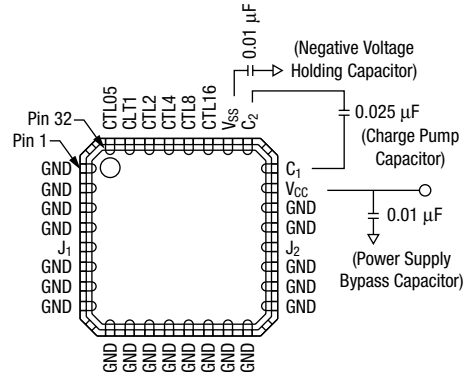

Description

The AA113-310 is a 6-bit, single positive control GaAs IC FET digital attenuator with driver. It is particularly suited at IF frequencies where high attenuation accuracy, low insertion loss and low intermodulation products are required. Typical applications include base station, wireless data, broadband and wireless local loop gain control circuits.

NEW Skyworks offers lead (Pb)-free, RoHS (Restriction of Hazardous Substances)-compliant packaging.



Electrical Specifications at 25 °C (0, 5 V)

Parameter ⁽¹⁾	Frequency	Min.	Typ.	Max.	Unit
Insertion loss ⁽²⁾	LF–0.5 GHz		1.5	1.8	dB
	LF–1.0 GHz		1.8	2.2	dB
Attenuation range ^(3, 4)			31.5		dB
Attenuation accuracy ^(3, 4)	LF–0.5 GHz	± (0.2 + 2% of attenuation setting in dB)			dB
	LF–1.0 GHz	± (0.25 + 3% of attenuation setting in dB)			dB
VSWR (I/O) ⁽⁴⁾	LF–1.0 GHz		1.4:1	1.6:1	

1. All measurements made in a 50 Ω system, unless otherwise specified.
 2. Insertion loss changes by 0.003 dB/°C.
 3. Attenuation referenced to insertion loss.
 4. Input/output.

Operating Characteristics at 25 °C (0, 5 V)

Parameter	Condition	Frequency	Min.	Typ.	Max.	Unit
Switching characteristics						
Rise, fall	10/90% or 90/10% RF			30		ns
On, off	50% CTL to 90/10% RF			50		ns
Video feedthru	$T_{RISE} = 1 \text{ ns}$, $BW = 500 \text{ MHz}$			50		mV
Input power for 1 dB compression	$V_{CC} = 5 \text{ V}$	0.5–1 GHz		29		dBm
		0.05 GHz		22		dBm
Intermodulation intercept point (IP3)	For two-tone input power 5 dBm	0.5–1 GHz		48		dBm
	$V_{CC} = 5 \text{ V}$	0.05 GHz		36		dBm
Thermal resistance				85		°C/W
Supply voltage	$V_{CC} = 2.7 \text{ to } 5 \text{ V @ } 700 \mu\text{A typ.}$					
Control voltages ⁽¹⁾	CTL05, CTL1, CTL2, CTL4, CTL8, CTL16, low = 0 to 0.8 V @ 20 $\mu\text{A typ.}$ CTL05, CTL2, CTL4, CTL8, CTL16, high = 2.7 to 5 V @ 20 $\mu\text{A typ.}$					

1. Control voltage must not exceed V_{CC} .

Typical Performance Data ($V_{CC} = 5 \text{ V}$)

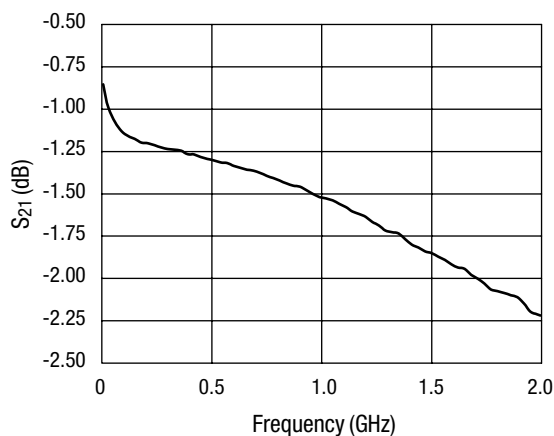

Insertion Loss vs. Frequency

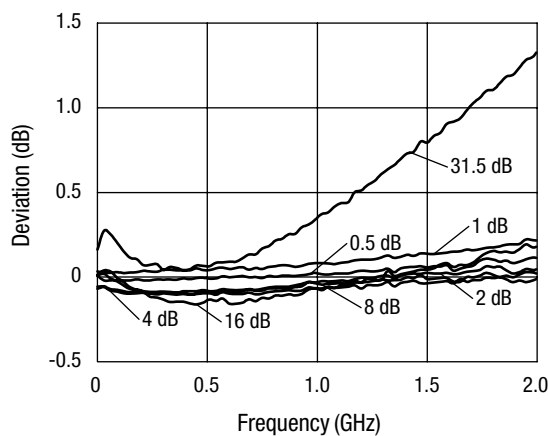

Attenuation Accuracy vs. Frequency

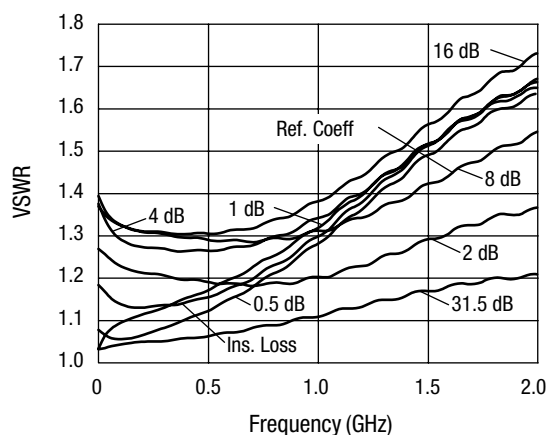

Input VSWR vs. Frequency

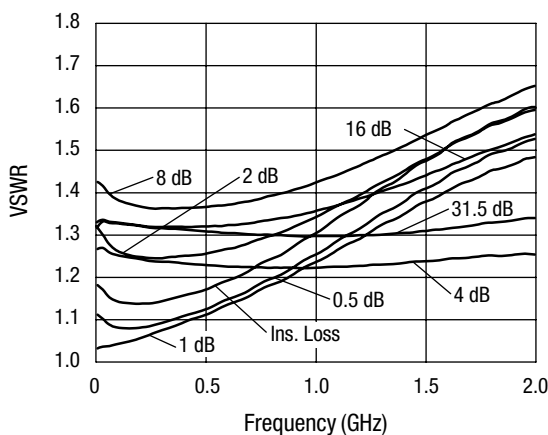

Output VSWR vs. Frequency

Surface Mount Land Pattern

5 x 5 mm QFN 32-Lead

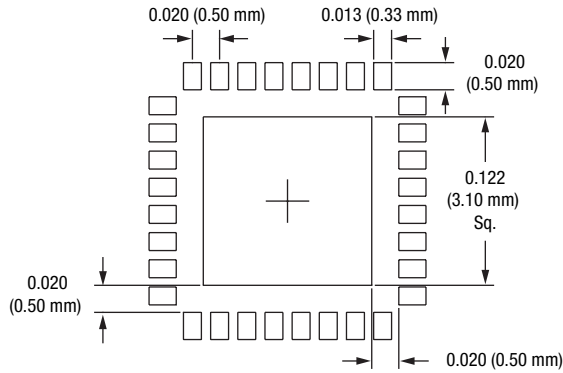

Dimensions in inches (mm).

Truth Table

CTL05	CTL1	CTL2	CTL4	CTL8	CTL16	Attenuation J ₁ -J ₂
0	0	0	0	0	0	Ins. loss
1	0	0	0	0	0	0.5 dB
0	1	0	0	0	0	1 dB
0	0	1	0	0	0	2 dB
0	0	0	1	0	0	4 dB
0	0	0	0	1	0	8 dB
0	0	0	0	0	1	16 dB
1	1	1	1	1	1	31.5 dB

"0" = 0 to 0.5 V (V_{CC} = 5 V).
 "1" = 2.7 to 5 V (V_{CC} = 5 V).

Recommended Solder Reflow Profiles

Refer to the "Recommended Solder Reflow Profile" Application Note.

Tape and Reel Information

Refer to the "Discrete Devices and IC Switch/Attenuators Tape and Reel Package Orientation" Application Note.

Absolute Maximum Ratings

Characteristic	Value
RF input power	2 W > 500 MHz, 0/6 V 0.5 W > 50 MHz, 0/6 V
Supply voltage	6 V
Control voltage ⁽¹⁾	-0.2 V, +6 V
Operating temperature	-40 °C to +85 °C
Storage temperature	-65 °C to +150 °C

1. Control voltage must not exceed supply voltage.
 Performance is guaranteed only under the conditions listed in the specifications table and is not guaranteed under the full range(s) described by the Absolute Maximum specifications. Exceeding any of the absolute maximum/minimum specifications may result in permanent damage to the device and will void the warranty.

CAUTION: Although this device is designed to be as robust as possible, ESD (Electrostatic Discharge) can damage this device. This device must be protected at all times from ESD. Static charges may easily produce potentials of several kilovolts on the human body or equipment, which can discharge without detection. Industry-standard ESD precautions must be employed at all times.

QFN 5 x 5 (-310)

