

RoHS Compliant Product
A suffix of "-C" specifies halogen and lead-free

DESCRIPTION

The S3U78xx-B series of fixed-voltage monolithic integrated-circuit voltage regulators designed for a wide range of applications. These applications include on-card regulation for elimination of noise and distribution problems associated with single-point regulation. Each of these regulators can deliver up to 1A of output current. The internal current limiting and thermal shutdown features of the regulators make them essentially immune to overload.

FEATURES

- 5V,6V,8V,9V,10V,12V,15V,18V,24V Output Voltage Available
- Output Transistor Safe-Area Compensation
- No External Components
- Internal Thermal Overload Protection
- Internal Short-Circuit Current Limiting
- High Power Dissipation Capability

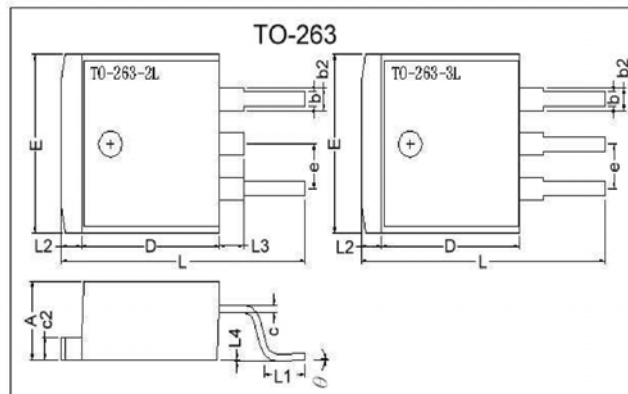

REF.	Millimeter		REF.	Millimeter	
	Min.	Max.		Min.	Max.
A	4.40	4.80	c2	1.25	1.45
b	0.76	1.00	b2	1.17	1.47
L4	0.00	0.30	D	8.6	9.0
c	0.36	0.5	e	2.54 REF.	
L3	1.50 REF.		L	14.6	15.8
L1	2.29	2.79	θ	0°	8°
E	9.80	10.4	L2	1.27 REF.	

MARKING

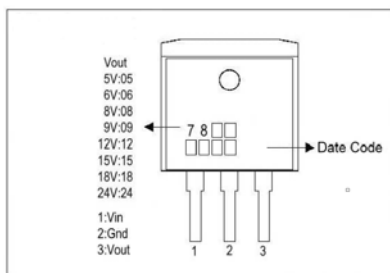

PACKAGE INFORMATION

Package	MPQ	LeaderSize
TO-263	0.8K	13' inch

ABSOLUTE MAXIMUM RATINGS

Parameter	Symbol	Value	Unit	
Input Voltage	V_{IN}	5V~18V	35	V
		24V	40	V
Output Current	I_o	1	A	
Operating Junction And Storage Temperature Range	T_j, T_{stg}	-55~150	°C	
Thermal Resistance Junction-Air	$R_{θJA}$	65	°C / W	
Thermal Resistance Junction-Cases	$R_{θJC}$	5	°C / W	

S3U7805-B ELECTRICAL CHARACTERISTICS

(Refer to the test circuits, $T_j=0\sim 125\text{ }^\circ\text{C}$, $I_o=500\text{mA}$, $V_{IN}=10\text{V}$, $C_{IN}=0.33\mu\text{F}$, $C_o=0.1\mu\text{F}$ unless otherwise specified)

Symbol	Test Conditions	Min	Typ	Max	Unit
V_o	B-Rank (5%) $V_{IN}=10\text{V}$, $I_o=500\text{mA}$, $T_j=25\text{ }^\circ\text{C}$ $7.5\text{V} \leq V_{IN} \leq 20\text{V}$, $5\text{mA} \leq I_o \leq 1\text{A}$, $P_D \leq 15\text{W}$	4.75	5.0	5.25	V
ΔV_o (Line Regulation)	$7\text{V} \leq V_{IN} \leq 25\text{V}$, $I_o=500\text{mA}$, $T_j=25\text{ }^\circ\text{C}$	-	3	50	mV
	$8\text{V} \leq V_{IN} \leq 12\text{V}$, $I_o=500\text{mA}$, $T_j=25\text{ }^\circ\text{C}$	-	1	25	
ΔV_o (Load Regulation)	$V_{IN}=10\text{V}$, $5\text{mA} \leq I_o \leq 1\text{A}$, $T_j=25\text{ }^\circ\text{C}$	-	-	100	mV
	$V_{IN}=10\text{V}$, $250\text{mA} \leq I_o \leq 750\text{mA}$, $T_j=25\text{ }^\circ\text{C}$	-	-	50	
I_q	$V_{IN}=10\text{V}$, $I_o=500\text{mA}$, $T_j=25\text{ }^\circ\text{C}$	-	-	8.0	mA
ΔI_q	$V_{IN}=10\text{V}$, $5\text{mA} \leq I_o \leq 1\text{A}$	-	-	0.5	mA
	$7\text{V} \leq V_{IN} \leq 25\text{V}$, $I_o=500\text{mA}$	-	-	1.3	
V_N	$10\text{Hz} \leq f \leq 100\text{KHz}$, $T_j=25\text{ }^\circ\text{C}$	-	40	-	μV
RR	$8\text{V} \leq V_{IN} \leq 18\text{V}$, $f=120\text{Hz}$, $T_j=25\text{ }^\circ\text{C}$	-	80	-	dB
V_D	$I_o=1\text{A}$, $T_j=25\text{ }^\circ\text{C}$	-	2	-	V
I_{SC}	$V_{IN}=35\text{V}$, $T_j=25\text{ }^\circ\text{C}$	-	250	-	mA
I_{PK}	$T_j=25\text{ }^\circ\text{C}$	-	1.8	-	A
$\Delta V_o/\Delta T_j$	$I_o=5\text{mA}$, $0\text{ }^\circ\text{C} \leq T_j \leq 125\text{ }^\circ\text{C}$	-	-0.6	-	$\text{mV}/\text{ }^\circ\text{C}$

S3U7806-B ELECTRICAL CHARACTERISTICS

(Refer to the test circuits, $T_j=0\sim 125\text{ }^\circ\text{C}$, $I_o=500\text{mA}$, $V_{IN}=11\text{V}$, $C_{IN}=0.33\mu\text{F}$, $C_o=0.1\mu\text{F}$ unless otherwise specified)

Symbol	Test Conditions	Min	Typ	Max	Unit
V_o	B-Rank (5%) $V_{IN}=11\text{V}$, $I_o=500\text{mA}$, $T_j=25\text{ }^\circ\text{C}$ $8\text{V} \leq V_{IN} \leq 21\text{V}$, $5\text{mA} \leq I_o \leq 1\text{A}$, $P_D \leq 15\text{W}$	5.7	6.0	6.3	V
ΔV_o (Line Regulation)	$8\text{V} \leq V_{IN} \leq 25\text{V}$, $I_o=500\text{mA}$, $T_j=25\text{ }^\circ\text{C}$	-	3	60	mV
	$9\text{V} \leq V_{IN} \leq 13\text{V}$, $I_o=500\text{mA}$, $T_j=25\text{ }^\circ\text{C}$	-	1	25	
ΔV_o (Load Regulation)	$V_{IN}=11\text{V}$, $5\text{mA} \leq I_o \leq 1\text{A}$, $T_j=25\text{ }^\circ\text{C}$	-	-	100	mV
	$V_{IN}=11\text{V}$, $250\text{mA} \leq I_o \leq 750\text{mA}$, $T_j=25\text{ }^\circ\text{C}$	-	-	50	
I_q	$V_{IN}=11\text{V}$, $I_o=500\text{mA}$, $T_j=25\text{ }^\circ\text{C}$	-	-	8	mA
ΔI_q	$V_{IN}=11\text{V}$, $5\text{mA} \leq I_o \leq 1\text{A}$	-	-	0.5	mA
	$8\text{V} \leq V_{IN} \leq 25\text{V}$, $I_o=500\text{mA}$	-	-	1.3	
V_N	$10\text{Hz} \leq f \leq 100\text{KHz}$, $T_j=25\text{ }^\circ\text{C}$	-	45	-	μV
RR	$9\text{V} \leq V_{IN} \leq 19\text{V}$, $f=120\text{Hz}$, $T_j=25\text{ }^\circ\text{C}$	-	75	-	dB
V_D	$I_o=1\text{A}$, $T_j=25\text{ }^\circ\text{C}$	-	2	-	V
I_{SC}	$V_{IN}=35\text{V}$, $T_j=25\text{ }^\circ\text{C}$	-	250	-	mA
I_{PK}	$T_j=25\text{ }^\circ\text{C}$	-	1.8	-	mA
$\Delta V_o/\Delta T_j$	$I_o=5\text{mA}$, $0\text{ }^\circ\text{C} \leq T_j \leq 125\text{ }^\circ\text{C}$	-	-0.7	-	$\text{mV}/\text{ }^\circ\text{C}$

S3U7808-B ELECTRICAL CHARACTERISTICS

(Refer to the test circuits, $T_j=0\sim 125\text{ }^\circ\text{C}$, $I_o=500\text{mA}$, $V_{IN}=14\text{V}$, $C_{IN}=0.33\mu\text{F}$, $C_o=0.1\mu\text{F}$ unless otherwise specified)

Symbol		Test Conditions	Min	Typ	Max	Unit
V_o	B-Rank (5%)	$V_{IN}=14\text{V}$, $I_o=500\text{mA}$, $T_j=25\text{ }^\circ\text{C}$ $10.5\text{V} \leq V_{IN} \leq 23\text{V}$, $5\text{mA} \leq I_o \leq 1\text{A}$, $P_D \leq 15\text{W}$	7.6	8.0	8.4	V
$\Delta V_o(\text{Line Regulation})$		$10.5\text{V} \leq V_{IN} \leq 25\text{V}$, $I_o=500\text{mA}$, $T_j=25\text{ }^\circ\text{C}$	-	3	80	mV
		$11\text{V} \leq V_{IN} \leq 17\text{V}$, $I_o=500\text{mA}$, $T_j=25\text{ }^\circ\text{C}$	-	1	40	
$\Delta V_o(\text{Load Regulation})$		$V_{IN}=14\text{V}$, $5\text{mA} \leq I_o \leq 1\text{A}$, $T_j=25\text{ }^\circ\text{C}$	-	-	100	mV
		$V_{IN}=14\text{V}$, $250\text{mA} \leq I_o \leq 750\text{mA}$, $T_j=25\text{ }^\circ\text{C}$	-	-	50	
I_q		$V_{IN}=14\text{V}$, $I_o=500\text{mA}$, $T_j=25\text{ }^\circ\text{C}$	-	-	8	mA
ΔI_q		$V_{IN}=14\text{V}$, $5\text{mA} \leq I_o \leq 1\text{A}$	-	-	0.5	mA
		$10.5\text{V} \leq V_{IN} \leq 25\text{V}$, $I_o=500\text{mA}$	-	-	1.3	
V_N		$10\text{Hz} \leq f \leq 100\text{KHz}$, $T_j=25\text{ }^\circ\text{C}$	-	58	-	μV
RR		$11.5\text{V} \leq V_{IN} \leq 21.5\text{V}$, $f=120\text{Hz}$, $T_j=25\text{ }^\circ\text{C}$	-	72	-	dB
V_D		$I_o=1\text{A}$, $T_j=25\text{ }^\circ\text{C}$	-	2	-	V
I_{SC}		$V_{IN}=35\text{V}$, $T_j=25\text{ }^\circ\text{C}$	-	250	-	mA
I_{PK}		$T_j=25\text{ }^\circ\text{C}$	-	1.8	-	A
$\Delta V_o/\Delta T_j$		$I_o=5\text{mA}$, $0\text{ }^\circ\text{C} \leq T_j \leq 125\text{ }^\circ\text{C}$	-	-0.9	-	$\text{mV}/\text{ }^\circ\text{C}$

S3U7809-B ELECTRICAL CHARACTERISTICS

(Refer to the test circuits, $T_j=0\sim 125\text{ }^\circ\text{C}$, $I_o=500\text{mA}$, $V_{IN}=15\text{V}$, $C_{IN}=0.33\mu\text{F}$, $C_o=0.1\mu\text{F}$ unless otherwise specified)

Symbol		Test Conditions	Min	Typ	Max	Unit
V_o	B-Rank (5%)	$V_{IN}=15\text{V}$, $I_o=500\text{mA}$, $T_j=25\text{ }^\circ\text{C}$ $11.5\text{V} \leq V_{IN} \leq 24\text{V}$, $5\text{mA} \leq I_o \leq 1\text{A}$, $P_D \leq 15\text{W}$	8.55	9.0	9.45	V
$\Delta V_o(\text{Line Regulation})$		$11.5\text{V} \leq V_{IN} \leq 25\text{V}$, $I_o=500\text{mA}$, $T_j=25\text{ }^\circ\text{C}$	-	5	90	mV
		$13\text{V} \leq V_{IN} \leq 19\text{V}$, $I_o=500\text{mA}$, $T_j=25\text{ }^\circ\text{C}$	-	3	45	
$\Delta V_o(\text{Load Regulation})$		$V_{IN}=15\text{V}$, $5\text{mA} \leq I_o \leq 1\text{A}$, $T_j=25\text{ }^\circ\text{C}$	-	-	100	mV
		$V_{IN}=15\text{V}$, $250\text{mA} \leq I_o \leq 750\text{mA}$, $T_j=25\text{ }^\circ\text{C}$	-	-	50	
I_q		$V_{IN}=15\text{V}$, $I_o=500\text{mA}$, $T_j=25\text{ }^\circ\text{C}$	-	-	8	mA
ΔI_q		$V_{IN}=15\text{V}$, $5\text{mA} \leq I_o \leq 1\text{A}$	-	-	0.5	mA
		$11.5\text{V} \leq V_{IN} \leq 26\text{V}$, $I_o=500\text{mA}$	-	-	1.3	
V_N		$10\text{Hz} \leq f \leq 100\text{KHz}$, $T_j=25\text{ }^\circ\text{C}$	-	58	-	μV
RR		$12.5\text{V} \leq V_{IN} \leq 22.5\text{V}$, $f=120\text{Hz}$, $T_j=25\text{ }^\circ\text{C}$	-	72	-	dB
V_D		$I_o=1\text{A}$, $T_j=25\text{ }^\circ\text{C}$	-	2	-	V
I_{SC}		$V_{IN}=35\text{V}$, $T_j=25\text{ }^\circ\text{C}$	-	250	-	mA
I_{PK}		$T_j=25\text{ }^\circ\text{C}$	-	1.8	-	mA
$\Delta V_o/\Delta T_j$		$I_o=5\text{mA}$, $0\text{ }^\circ\text{C} \leq T_j \leq 125\text{ }^\circ\text{C}$	-	-1.1	-	$\text{mV}/\text{ }^\circ\text{C}$

S3U7812-B ELECTRICAL CHARACTERISTICS

(Refer to the test circuits, $T_j=0\sim 125\text{ }^\circ\text{C}$, $I_o=500\text{mA}$, $V_{IN}=19\text{V}$, $C_{IN}=0.33\mu\text{F}$, $C_o=0.1\mu\text{F}$ unless otherwise specified)

Symbol		Test Conditions	Min	Typ	Max	Unit
V_o	B-Rank (5%)	$V_{IN}=19\text{V}$, $I_o=500\text{mA}$, $T_j=25\text{ }^\circ\text{C}$ $14.5\text{V} \leq V_{IN} \leq 27\text{V}$, $5\text{mA} \leq I_o \leq 1\text{A}$, $P_D \leq 15\text{W}$	11.4	12.0	12.6	V
$\Delta V_o(\text{Line Regulation})$		$14.5\text{V} \leq V_{IN} \leq 30\text{V}$, $I_o=500\text{mA}$, $T_j=25\text{ }^\circ\text{C}$	-	10	120	mV
		$16\text{V} \leq V_{IN} \leq 22\text{V}$, $I_o=500\text{mA}$, $T_j=25\text{ }^\circ\text{C}$	-	3	60	
$\Delta V_o(\text{Load Regulation})$		$V_{IN}=19\text{V}$, $5\text{mA} \leq I_o \leq 1\text{A}$, $T_j=25\text{ }^\circ\text{C}$	-	-	100	mV
		$V_{IN}=19\text{V}$, $250\text{mA} \leq I_o \leq 750\text{mA}$, $T_j=25\text{ }^\circ\text{C}$	-	-	60	
I_q		$V_{IN}=19\text{V}$, $I_o=500\text{mA}$, $T_j=25\text{ }^\circ\text{C}$	-	-	8	mA
ΔI_q		$V_{IN}=19\text{V}$, $5\text{mA} \leq I_o \leq 1\text{A}$	-	-	0.5	mA
		$14.5\text{V} \leq V_{IN} \leq 30\text{V}$, $I_o=500\text{mA}$	-	-	1.3	
V_N		$10\text{Hz} \leq f \leq 100\text{KHz}$, $T_j=25\text{ }^\circ\text{C}$	-	75	-	μV
RR		$15\text{V} \leq V_{IN} \leq 25\text{V}$, $f=120\text{Hz}$, $T_j=25\text{ }^\circ\text{C}$	-	72	-	dB
V_D		$I_o=1\text{A}$, $T_j=25\text{ }^\circ\text{C}$	-	2	-	V
I_{SC}		$V_{IN}=35\text{V}$, $T_j=25\text{ }^\circ\text{C}$	-	250	-	mA
I_{PK}		$T_j=25\text{ }^\circ\text{C}$	-	1.8	-	mA
$\Delta V_o/\Delta T_j$		$I_o=5\text{mA}$, $0\text{ }^\circ\text{C} \leq T_j \leq 125\text{ }^\circ\text{C}$	-	-1.5	-	$\text{mV}/\text{ }^\circ\text{C}$

S3U7815-B ELECTRICAL CHARACTERISTICS

(Refer to the test circuits, $T_j=0\sim 125\text{ }^\circ\text{C}$, $I_o=500\text{mA}$, $V_{IN}=23\text{V}$, $C_{IN}=0.33\mu\text{F}$, $C_o=0.1\mu\text{F}$ unless otherwise specified)

Symbol		Test Conditions	Min	Typ	Max	Unit
V_o	B-Rank (5%)	$V_{IN}=23\text{V}$, $I_o=500\text{mA}$, $T_j=25\text{ }^\circ\text{C}$ $17.5\text{V} \leq V_{IN} \leq 30\text{V}$, $5\text{mA} \leq I_o \leq 1\text{A}$, $P_D \leq 15\text{W}$	14.25	15.0	15.75	V
$\Delta V_o(\text{Line Regulation})$		$17.5\text{V} \leq V_{IN} \leq 30\text{V}$, $I_o=500\text{mA}$, $T_j=25\text{ }^\circ\text{C}$	-	-	150	mV
		$17.5\text{V} \leq V_{IN} \leq 30\text{V}$, $I_o=500\text{mA}$, $T_j=25\text{ }^\circ\text{C}$	-	-	75	
$\Delta V_o(\text{Load Regulation})$		$V_{IN}=23\text{V}$, $5\text{mA} \leq I_o \leq 1\text{A}$, $T_j=25\text{ }^\circ\text{C}$	-	-	150	mV
		$V_{IN}=23\text{V}$, $250\text{mA} \leq I_o \leq 750\text{mA}$, $T_j=25\text{ }^\circ\text{C}$	-	-	75	
I_q		$V_{IN}=23\text{V}$, $I_o=500\text{mA}$, $T_j=25\text{ }^\circ\text{C}$	-	-	8	mA
ΔI_q		$V_{IN}=23\text{V}$, $5\text{mA} \leq I_o \leq 1\text{A}$	-	-	0.5	mA
		$17.5\text{V} \leq V_{IN} \leq 30\text{V}$, $I_o=500\text{mA}$	-	-	1.3	
V_N		$10\text{Hz} \leq f \leq 100\text{KHz}$, $T_j=25\text{ }^\circ\text{C}$	-	90	-	μV
RR		$18.5\text{V} \leq V_{IN} \leq 28.5\text{V}$, $f=120\text{Hz}$, $T_j=25\text{ }^\circ\text{C}$	-	70	-	dB
V_D		$I_o=1\text{A}$, $T_j=25\text{ }^\circ\text{C}$	-	2	-	V
I_{SC}		$V_{IN}=35\text{V}$, $T_j=25\text{ }^\circ\text{C}$	-	250	-	mA
I_{PK}		$T_j=25\text{ }^\circ\text{C}$	-	1.8	-	mA
$\Delta V_o/\Delta T_j$		$I_o=5\text{mA}$, $0\text{ }^\circ\text{C} \leq T_j \leq 125\text{ }^\circ\text{C}$	-	-1.8	-	$\text{mV}/\text{ }^\circ\text{C}$

S3U7818-B ELECTRICAL CHARACTERISTICS

(Refer to the test circuits, $T_j=0\sim 125\text{ }^\circ\text{C}$, $I_o=500\text{mA}$, $V_{IN}=27\text{V}$, $C_{IN}=0.33\mu\text{F}$, $C_o=0.1\mu\text{F}$ unless otherwise specified)

Symbol		Test Conditions	Min	Typ	Max	Unit
V_o	B-Rank (5%)	$V_{IN}=27\text{V}$, $I_o=500\text{mA}$, $T_j=25\text{ }^\circ\text{C}$ $21\text{V} \leq V_{IN} \leq 33\text{V}$, $5\text{mA} \leq I_o \leq 1\text{A}$, $P_D \leq 15\text{W}$	17.1	18.0	18.9	V
ΔV_o (Line Regulation)		$21\text{V} \leq V_{IN} \leq 33\text{V}$, $I_o=500\text{mA}$, $T_j=25\text{ }^\circ\text{C}$	-	-	180	mV
		$24\text{V} \leq V_{IN} \leq 30\text{V}$, $I_o=500\text{mA}$, $T_j=25\text{ }^\circ\text{C}$	-	-	90	
ΔV_o (Load Regulation)		$V_{IN}=27\text{V}$, $5\text{mA} \leq I_o \leq 1\text{A}$, $T_j=25\text{ }^\circ\text{C}$	-	-	180	mV
		$V_{IN}=27\text{V}$, $250\text{mA} \leq I_o \leq 750\text{mA}$, $T_j=25\text{ }^\circ\text{C}$	-	-	90	
I_q		$V_{IN}=27\text{V}$, $I_o=500\text{mA}$, $T_j=25\text{ }^\circ\text{C}$	-	-	8	mA
ΔI_q		$V_{IN}=27\text{V}$, $5\text{mA} \leq I_o \leq 1\text{A}$	-	-	0.5	mA
		$21\text{V} \leq V_{IN} \leq 33\text{V}$, $I_o=500\text{mA}$	-	-	1.3	
V_N		$10\text{Hz} \leq f \leq 100\text{KHz}$, $T_j=25\text{ }^\circ\text{C}$	-	110	-	μV
RR		$22\text{V} \leq V_{IN} \leq 32\text{V}$, $f=120\text{Hz}$, $T_j=25\text{ }^\circ\text{C}$	-	69	-	dB
V_D		$I_o=1\text{A}$, $T_j=25\text{ }^\circ\text{C}$	-	2	-	V
I_{SC}		$V_{IN}=35\text{V}$, $T_j=25\text{ }^\circ\text{C}$	-	250	-	mA
I_{PK}		$T_j=25\text{ }^\circ\text{C}$	-	1.8	-	mA
$\Delta V_o/\Delta T_j$		$I_o=5\text{mA}$, $0\text{ }^\circ\text{C} \leq T_j \leq 125\text{ }^\circ\text{C}$	-	-2.2	-	$\text{mV}/\text{ }^\circ\text{C}$

S3U7824-B ELECTRICAL CHARACTERISTICS

(Refer to the test circuits, $T_j=0\sim 125\text{ }^\circ\text{C}$, $I_o=500\text{mA}$, $V_{IN}=33\text{V}$, $C_{IN}=0.33\mu\text{F}$, $C_o=0.1\mu\text{F}$ unless otherwise specified)

Symbol		Test Conditions	Min	Typ	Max	Unit
V_o	B-Rank (5%)	$V_{IN}=33\text{V}$, $I_o=500\text{mA}$, $T_j=25\text{ }^\circ\text{C}$ $27\text{V} \leq V_{IN} \leq 38\text{V}$, $5\text{mA} \leq I_o \leq 1\text{A}$, $P_D \leq 15\text{W}$	22.8	24.0	25.2	V
ΔV_o (Line Regulation)		$27\text{V} \leq V_{IN} \leq 38\text{V}$, $I_o=500\text{mA}$, $T_j=25\text{ }^\circ\text{C}$	-	-	240	mV
		$30\text{V} \leq V_{IN} \leq 36\text{V}$, $I_o=500\text{mA}$, $T_j=25\text{ }^\circ\text{C}$	-	-	120	
ΔV_o (Load Regulation)		$V_{IN}=33\text{V}$, $5\text{mA} \leq I_o \leq 1\text{A}$, $T_j=25\text{ }^\circ\text{C}$	-	-	240	mV
		$V_{IN}=33\text{V}$, $250\text{mA} \leq I_o \leq 750\text{mA}$, $T_j=25\text{ }^\circ\text{C}$	-	-	120	
I_q		$V_{IN}=33\text{V}$, $I_o=500\text{mA}$, $T_j=25\text{ }^\circ\text{C}$	-	-	8	mA
ΔI_q		$V_{IN}=33\text{V}$, $5\text{mA} \leq I_o \leq 1\text{A}$	-	-	0.5	mA
		$28\text{V} \leq V_{IN} \leq 38\text{V}$, $I_o=500\text{mA}$	-	-	1.0	
V_N		$10\text{Hz} \leq f \leq 100\text{KHz}$, $T_j=25\text{ }^\circ\text{C}$	-	170	-	μV
RR		$28\text{V} \leq V_{IN} \leq 38\text{V}$, $f=120\text{Hz}$, $T_j=25\text{ }^\circ\text{C}$	-	66	-	dB
V_D		$I_o=1\text{A}$, $T_j=25\text{ }^\circ\text{C}$	-	2	-	V
I_{SC}		$V_{IN}=35\text{V}$, $T_j=25\text{ }^\circ\text{C}$	-	250	-	mA
I_{PK}		$T_j=25\text{ }^\circ\text{C}$	-	1.8	-	mA
$\Delta V_o/\Delta T_j$		$I_o=5\text{mA}$, $0\text{ }^\circ\text{C} \leq T_j \leq 125\text{ }^\circ\text{C}$	-	-2.8	-	$\text{mV}/\text{ }^\circ\text{C}$

TYPICAL APPLICATION

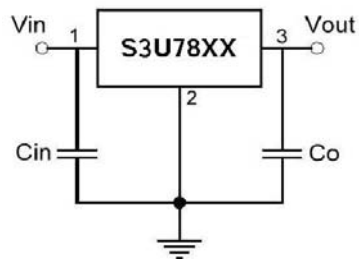

CHARACTERISTIC CURVE

