

Thermally-Enhanced High Power RF LDMOS FETs 340 W, 30 V, 1930 – 1990 MHz

Description

The PTFB193404F is a 340-watt LDMOS FET intended for use in multi-standard cellular power amplifier applications in the 1930 to 1990 MHz frequency band. Features include input and output matching, high gain and thermally-enhanced package with earless flange. Manufactured with Infineon's advanced LDMOS process, this device provides excellent thermal performance and superior reliability.

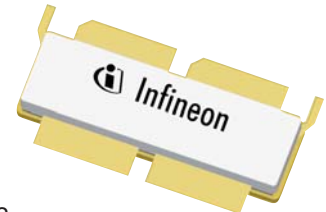

PTFB193404F
Package H-37275-6/2

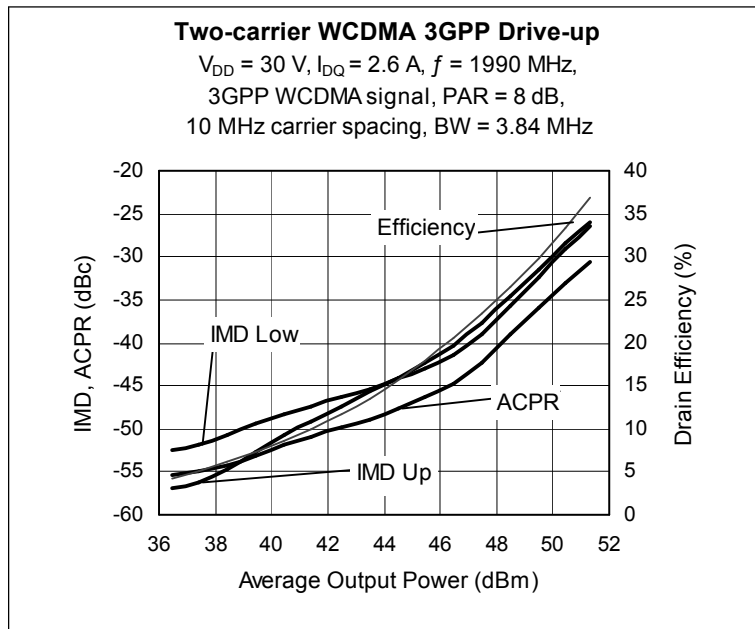

Features

- Broadband internal matching
- Wide video bandwidth
- Typical single-carrier WCDMA performance, 1990 MHz, 30 V
 - Output power = 125 W
 - Efficiency = 31%
 - Gain = 17 dB
 - PAR = 5.5 dB @ 0.01% CCDF
 - ACPR @ 5 MHz = -35 dBc
- Increased negative gate-source voltage range for improved performance in Doherty amplifiers
- Capable of handling 10:1 VSWR @ 30 V, 340 W (CW) output power
- Integrated ESD protection
- Excellent thermal stability
- Pb-free and RoHS compliant

RF Characteristics

Two-carrier WCDMA Measurements (tested in Infineon test fixture)

$V_{DD} = 30\text{ V}$, $I_{DQ} = 2.6\text{ A}$, $P_{OUT} = 80\text{ W}$ average, $f = 1990\text{ MHz}$, 5 MHz spacing, 3GPP signal, channel bandwidth = 3.84 MHz, peak/average = 7.5 dB @ 0.01% CCDF

Characteristic	Symbol	Min	Typ	Max	Unit
Gain	G_{ps}	17.5	19	—	dB
Drain Efficiency	η_D	28.5	30	—	%
Adjacent Channel Power Ratio	ACPR	—	-31	-29	dBc

All published data at $T_{CASE} = 25^\circ\text{C}$ unless otherwise indicated

ESD: Electrostatic discharge sensitive device—observe handling precautions!

RF Characteristics (cont.)

Two-carrier WCDMA Characteristics (not subject to production test—verified by design/characterization in Infineon test fixture)
 $V_{DD} = 30\text{ V}$, $I_{DQ} = 2.6\text{ A}$, $P_{OUT} = 80\text{ W}$ average, $f_1 = 1980\text{ MHz}$, $f_2 = 1990\text{ MHz}$, 3GPP signal, channel bandwidth = 3.84 MHz, peak/average = 7.5 dB @ 0.01% CCDF

Characteristic	Symbol	Min	Typ	Max	Unit
Gain	G_{ps}	—	18	—	dB
Drain Efficiency	η_D	—	29	—	%
Intermodulation Distortion	IMD	—	-33	—	dBc

Two-tone Characteristics (not subject to production test—verified by design/characterization in Infineon test fixture)
 $V_{DD} = 30\text{ V}$, $I_{DQ} = 2.6\text{ A}$, $P_{OUT} = 265\text{ W}$ PEP, $f = 1990\text{ MHz}$, tone spacing = 1 MHz

Characteristic	Symbol	Min	Typ	Max	Unit
Gain	G_{ps}	—	19	—	dB
Drain Efficiency	η_D	—	36	—	%
Intermodulation Distortion	IMD	—	30	—	dBc

DC Characteristics

Characteristic	Conditions	Symbol	Min	Typ	Max	Unit
Drain-Source Breakdown Voltage	$V_{GS} = 0\text{ V}$, $I_{DS} = 10\text{ mA}$	$V_{(BR)DSS}$	65	—	—	V
Drain Leakage Current	$V_{DS} = 28\text{ V}$, $V_{GS} = 0\text{ V}$	I_{DSS}	—	—	1.0	μA
	$V_{DS} = 63\text{ V}$, $V_{GS} = 0\text{ V}$	I_{DSS}	—	—	10.0	μA
On-State Resistance	$V_{GS} = 10\text{ V}$, $V_{DS} = 0.1\text{ V}$	$R_{DS(on)}$	—	0.05	—	Ω
Operating Gate Voltage	$V_{DS} = 30\text{ V}$, $I_{DQ} = 2.6\text{ A}$	V_{GS}	2.3	2.8	3.3	V
Gate Leakage Current	$V_{GS} = 10\text{ V}$, $V_{DS} = 0\text{ V}$	I_{GSS}	—	—	1.0	μA

Maximum Ratings

Parameter	Symbol	Value	Unit
Drain-Source Voltage	V_{DSS}	65	V
Gate-Source Voltage	V_{GS}	-6 to +10	V
Junction Temperature	T_J	200	$^{\circ}\text{C}$
Storage Temperature Range	T_{STG}	-40 to +150	$^{\circ}\text{C}$
Thermal Resistance ($T_{CASE} = 70^{\circ}\text{C}$)	$R_{\theta JC}$	0.2	$^{\circ}\text{C/W}$

Ordering Information

Type and Version	Package Outline	Package Description	Shipping
PTFB193404F V1	H-37275-6/2	Ceramic open-cavity, earless push-pull	Tray
PTFB193404F V1 R250	H-37275-6/2	Ceramic open-cavity, earless push-pull	Tape & reel, 250 pcs

Typical Performance (data taken in production test fixture)

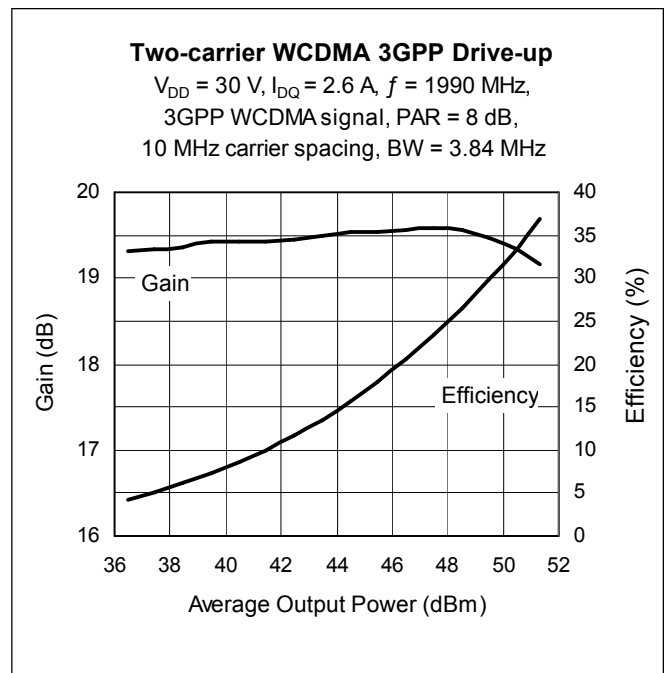
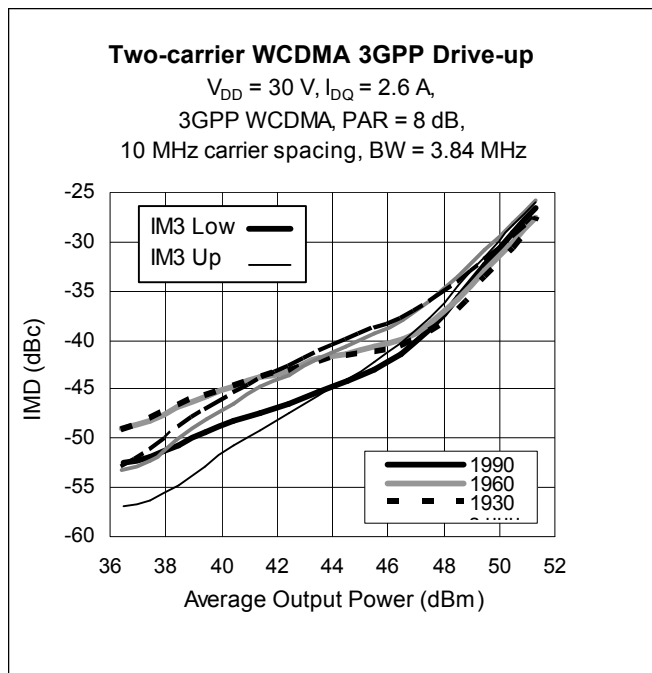

Typical Performance (cont.)

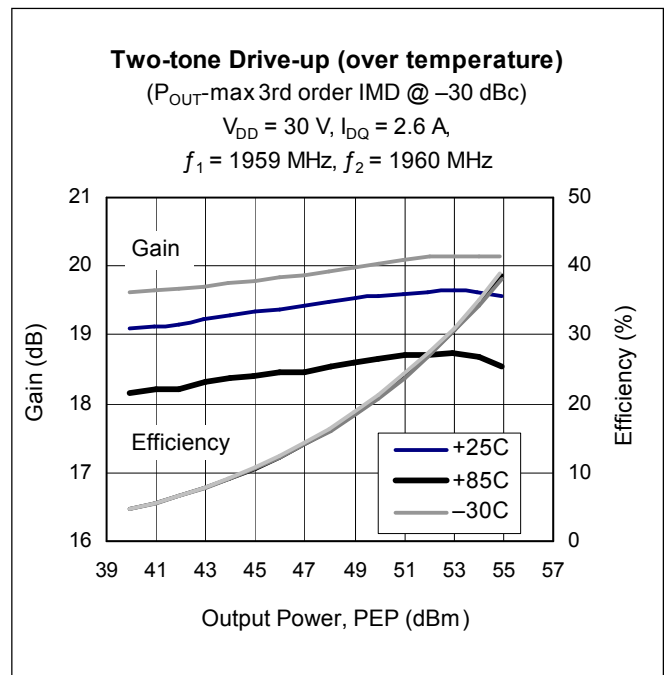
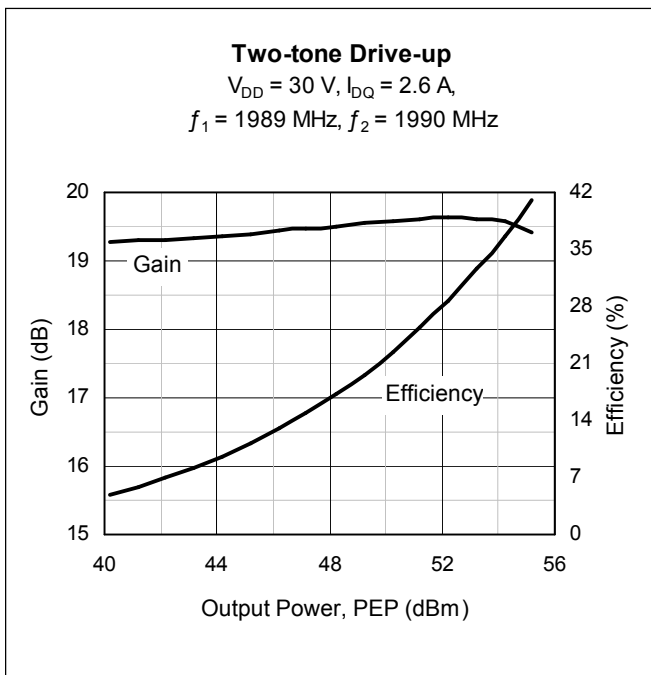
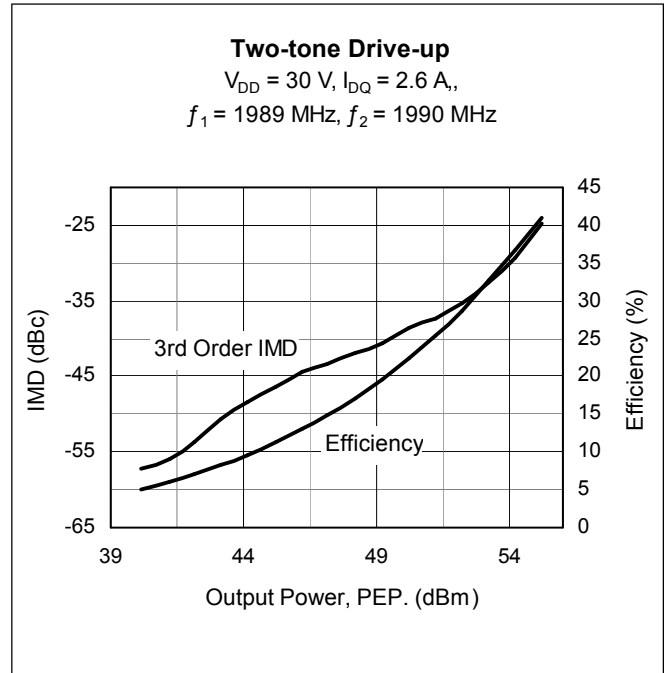
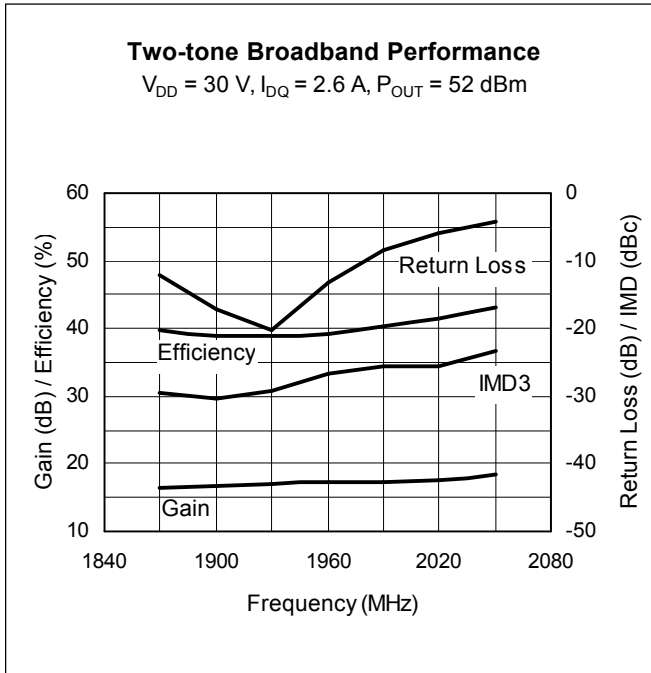

Typical Performance (cont.)

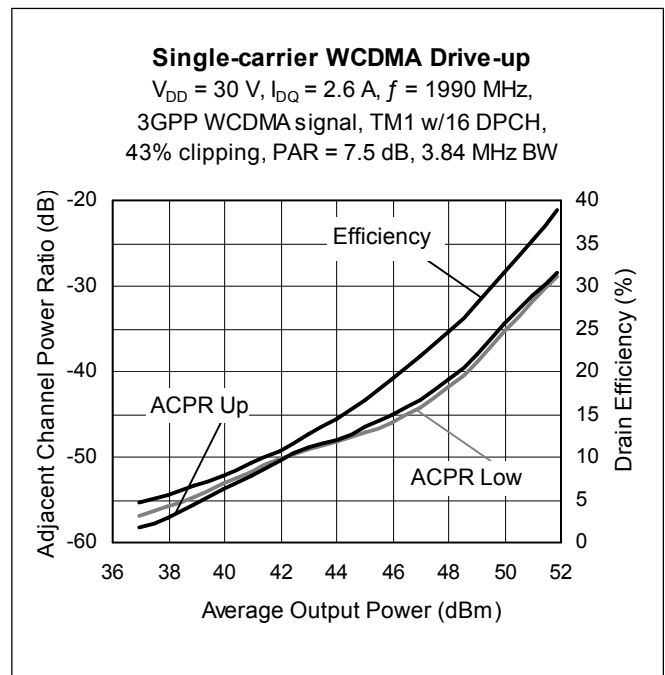
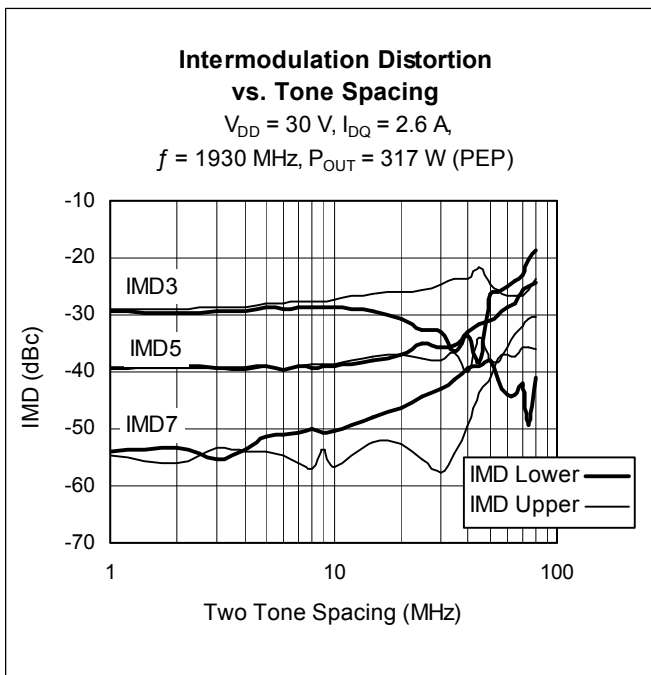
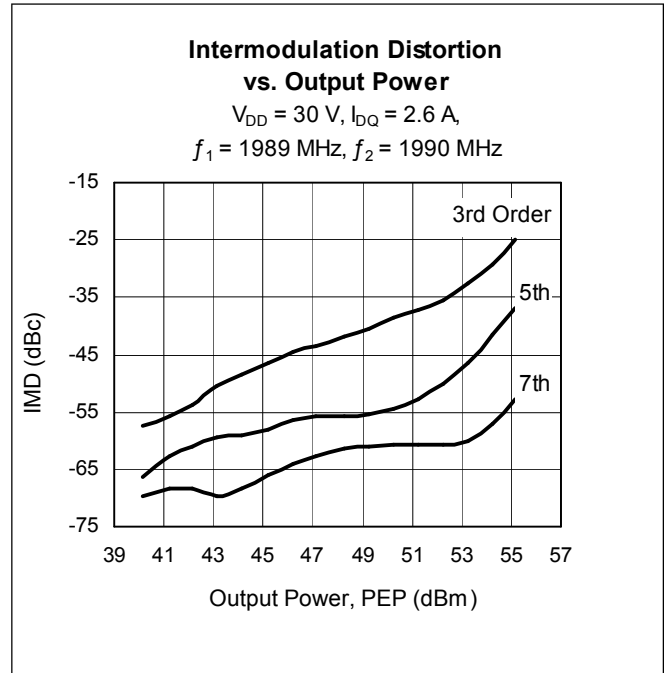
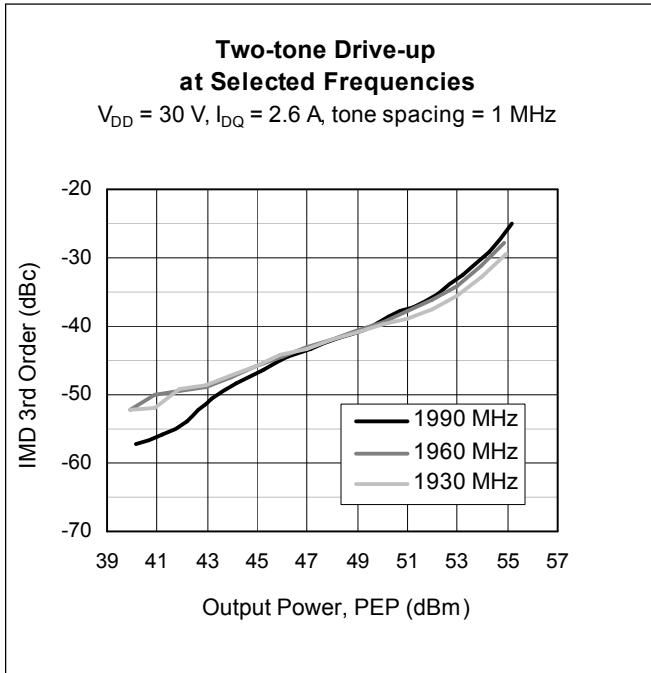

Typical Performance (cont.)

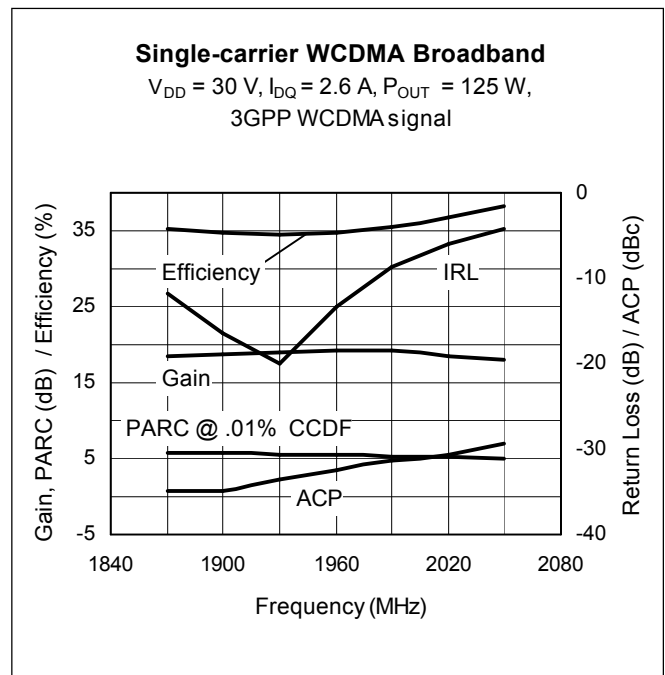
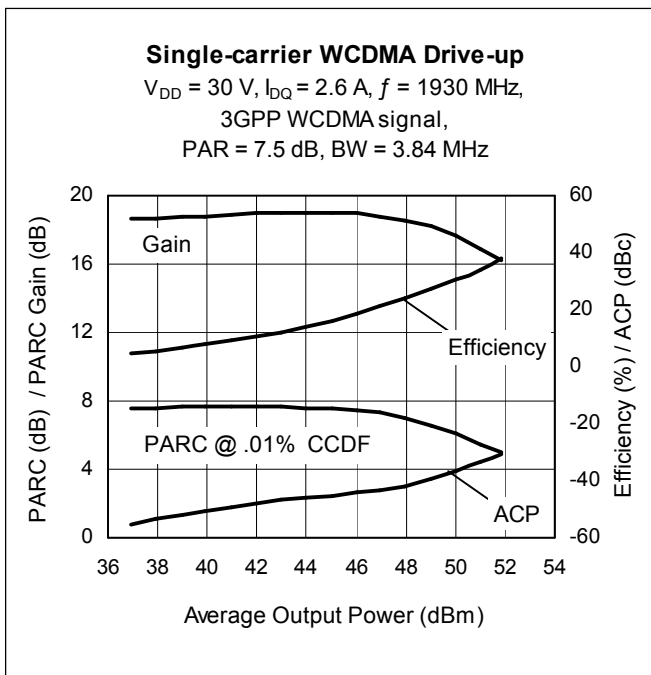
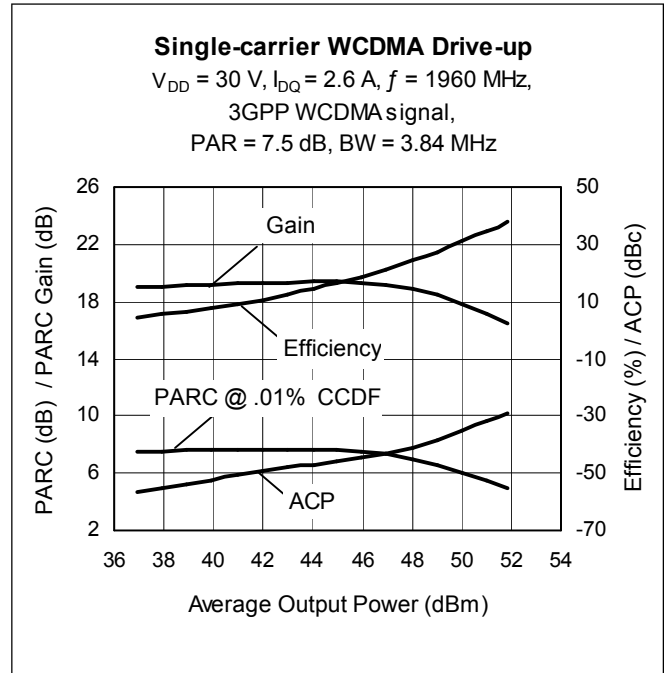
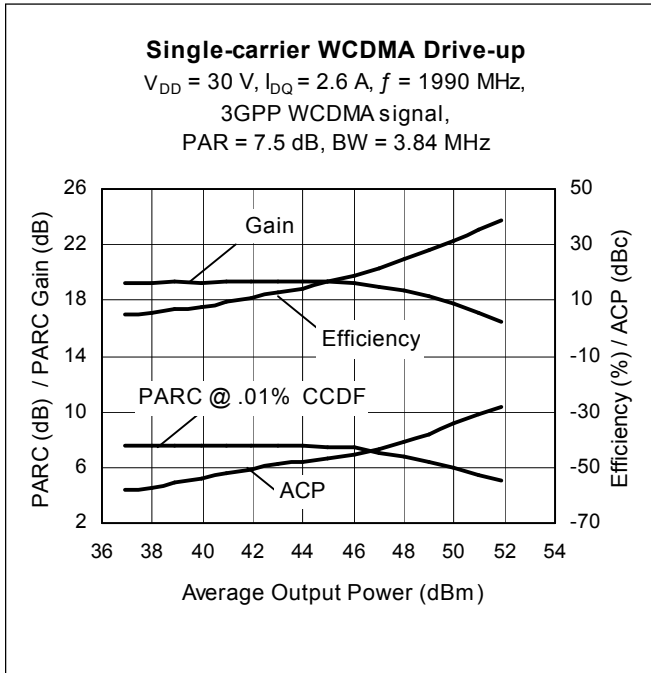

Broadband Circuit Impedance (measurements taken on full part, both sides)

Frequency	Z Source Ω		Z Load Ω	
	R	jX	R	jX
1900	1.21	-3.60	0.73	-2.08
1930	1.21	-3.53	0.72	-2.01
1960	1.20	-3.47	0.72	-1.94
1990	1.20	-3.41	0.72	-1.87
2020	1.19	-3.35	0.72	-1.81

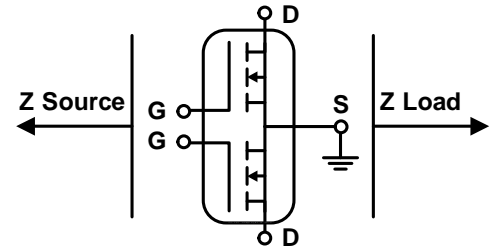

See next page for circuit information

Reference Circuit

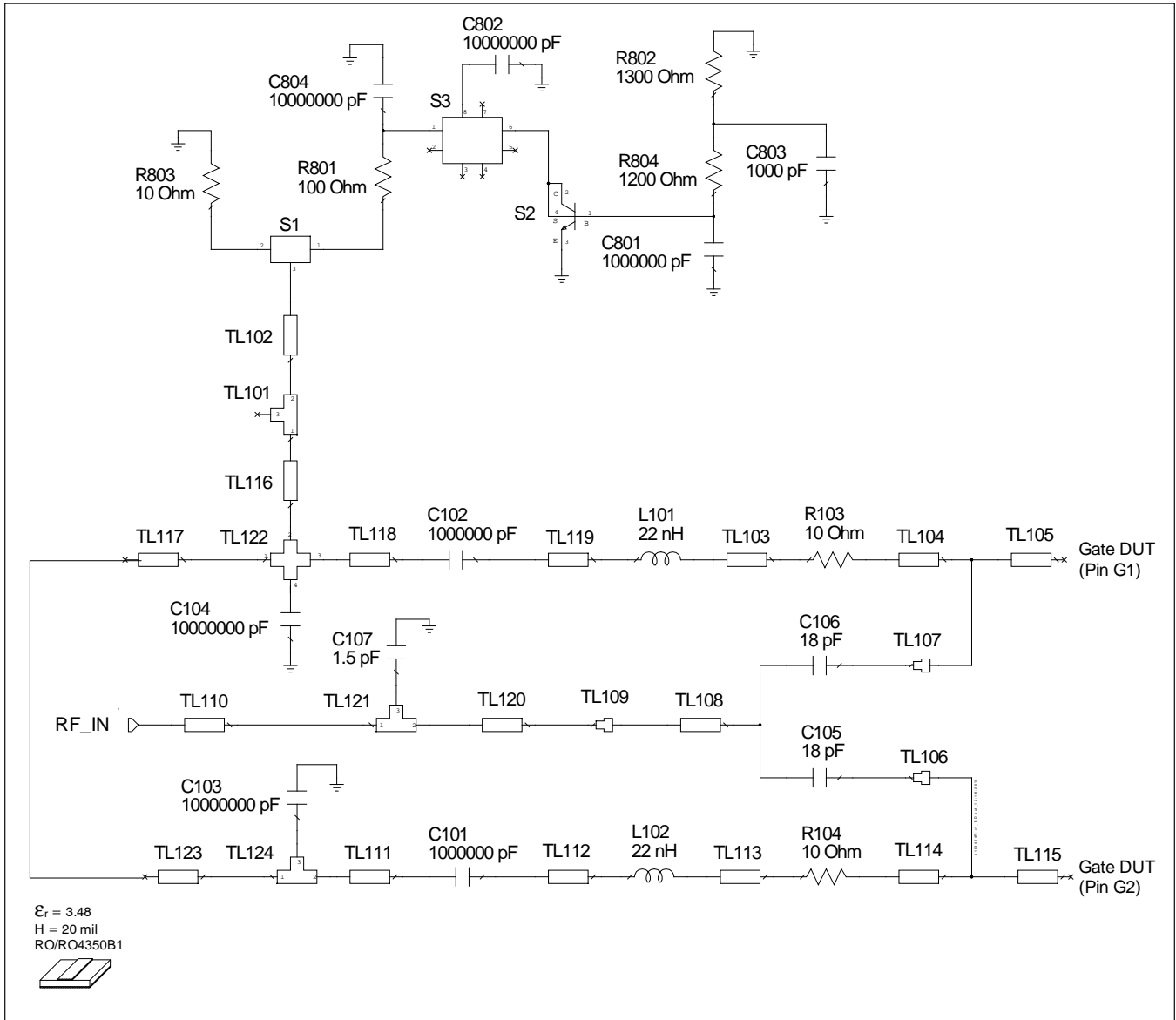

Reference circuit input schematic for $f = 1990 \text{ MHz}$

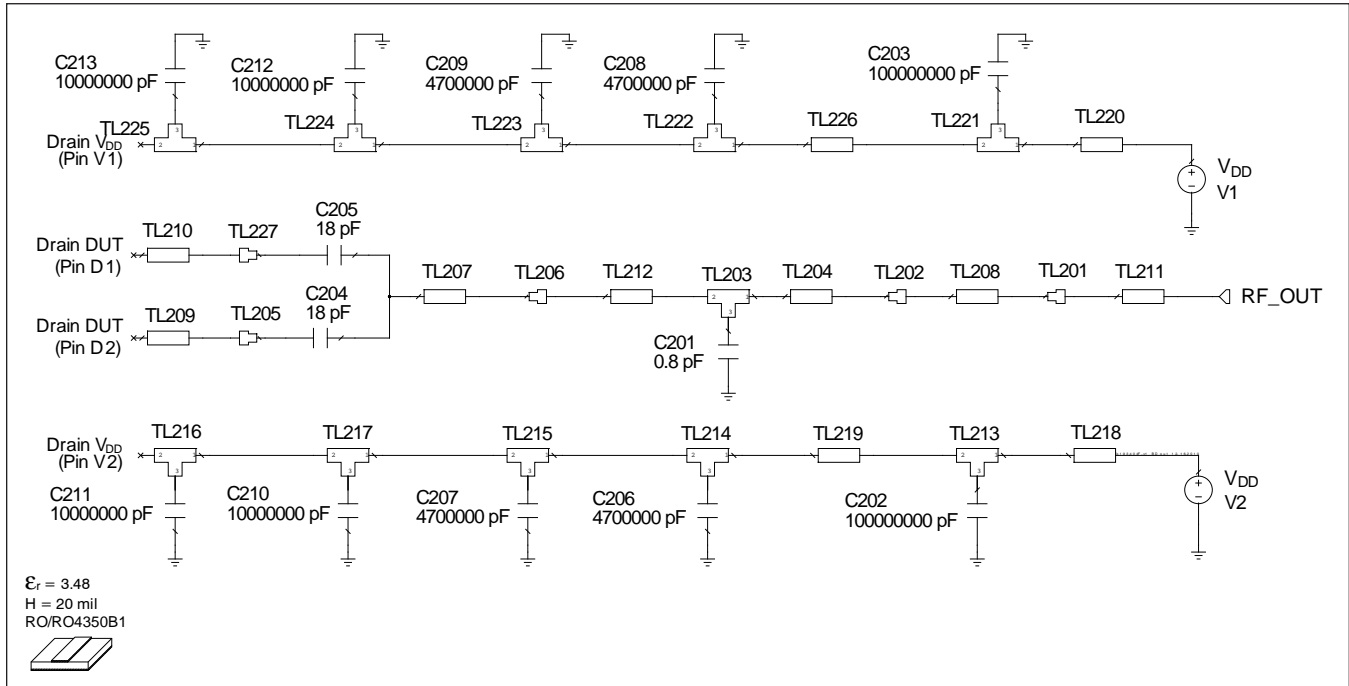
Reference Circuit (cont.)

Reference circuit output schematic for $f = 1990$ MHz
Reference Circuit Assembly

DUT	PTFB193404F
Test Fixture Part No.	LTN/PTFB193404EF
PCB	Rogers RO4350, 0.508 mm [0.020"] thick, 1 oz. copper, $\epsilon_r = 3.48$ copper
Find Gerber files for this test fixture on the Infineon Web site at http://www.infineon.com/rfpower	

Transmission Line	Electrical Characteristics	Dimensions: W, L (mm)	Dimensions: W, L (mils)
TL101	0.017λ , 47.12 Ω	W1 = 1.270, W2 = 1.270, W3 = 1.524	W1 = 50, W2 = 50, W3 = 60
TL102	0.039λ , 47.12 Ω	W = 1.270, L = 3.553	W = 50, L = 140
TL103	0.023λ , 47.12 Ω	W = 1.270, L = 2.055	W = 50, L = 81
TL104	0.013λ , 47.12 Ω	W = 1.270, L = 1.168	W = 50, L = 46
TL105	0.122λ , 7.29 Ω	W = 12.700, L = 10.160	W = 500, L = 400
TL106		W1 = 0.010, W2 = 1.168, Offset = 5.893	W1 = 10, W2 = 46, Offset = 232
TL107		W1 = 0.010, W2 = 1.168, Offset = -5.893	W1 = 10, W2 = 46, Offset = -232
TL108	0.007λ , 34.08 Ω	W = 2.032, L = 0.635	W = 80, L = 25
TL109	0.012λ , 34.08 Ω	W1 = 2.032, W2 = 1.034	W1 = 80, W2 = 41
TL110	0.055λ , 53.60 Ω	W = 1.034, L = 5.029	W = 41, L = 198
TL111	0.023λ , 47.12 Ω	W = 1.270, L = 2.111	W = 50, L = 83
TL112	0.017λ , 47.12 Ω	W = 1.270, L = 1.524	W = 50, L = 60
TL113	0.023λ , 47.12 Ω	W = 1.270, L = 2.055	W = 50, L = 81

table continued on page 9

Reference Circuit (cont.)

Transmission Line	Electrical Characteristics	Dimensions: W, L (mm)	Dimensions: W, L (mils)
Input (cont.)			
TL114	0.013 λ , 47.12 Ω	W = 1.270, L = 1.168	W = 50, L = 46
TL115	0.122 λ , 7.29 Ω	W = 12.700, L = 10.160	W = 500, L = 400
TL116	0.068 λ , 47.12 Ω	W = 1.270, L = 6.170	W = 50, L = 243
TL117	0.032 λ , 47.12 Ω	W = 1.270, L = 2.875	W = 50, L = 113
TL118	0.024 λ , 47.12 Ω	W = 1.270, L = 2.131	W = 50, L = 84
TL119	0.017 λ , 47.12 Ω	W = 1.270, L = 1.524	W = 50, L = 60
TL120	0.084 λ , 53.60 Ω	W = 1.034, L = 7.671	W = 41, L = 302
TL121	0.014 λ , 53.60 Ω	W1 = 1.034, W2 = 1.034, W3 = 1.27	W1 = 41, W2 = 41, W3 = 50
TL122	0.014 λ , 47.12 Ω	W1 = 1.270, W2 = 1.270, W3 = 1.270, W4 = 1.270	W1 = 50, W2 = 50, W3 = 50, W4 = 50
TL123	0.032 λ , 47.12 Ω	W = 1.270, L = 2.896	W = 50, L = 114
TL124	0.014 λ , 47.12 Ω	W1 = 1.270, W2 = 1.270, W3 = 1.27	W1 = 50, W2 = 50, W3 = 50
Output			
TL201		W1 = 1.577, W2 = 1.046	W1 = 62, W2 = 41
TL202		W1 = 2.263, W2 = 1.577	W1 = 89, W2 = 62
TL203	0.009 λ , 31.48 Ω	W1 = 2.263, W2 = 2.263, W3 = 0.762	W1 = 89, W2 = 89, W3 = 30
TL204	0.139 λ , 31.48 Ω	W = 2.263, L = 12.299	W = 89, L = 484
TL205		W1 = 0.001, W2 = 13.335, Offset = -6.223	W1 = 1, W2 = 525, Offset = -245
TL206		W1 = 3.048, W2 = 2.263	W1 = 120, W2 = 89
TL207	0.009 λ , 25.04 Ω	W = 3.048, L = 0.762	W = 120, L = 30
TL208	0.266 λ , 40.78 Ω	W = 1.577, L = 23.889	W = 62, L = 941
TL209	0.160 λ , 6.97 Ω	W = 13.335, L = 13.335	W = 525, L = 525
TL210	0.160 λ , 6.97 Ω	W = 13.335, L = 13.335	W = 525, L = 525
TL211	0.151 λ , 53.21 Ω	W = 1.046, L = 13.774	W = 41, L = 542
TL212	0.120 λ , 31.48 Ω	W = 2.263, L = 10.617	W = 89, L = 418
TL213	0.024 λ , 19.85 Ω	W1 = 4.064, W2 = 4.064, W3 = 2.032	W1 = 160, W2 = 160, W3 = 80
TL214	0.026 λ , 19.85 Ω	W1 = 4.064, W2 = 4.064, W3 = 2.286	W1 = 160, W2 = 160, W3 = 90
TL215	0.026 λ , 19.85 Ω	W1 = 4.064, W2 = 4.064, W3 = 2.286	W1 = 160, W2 = 160, W3 = 90
TL216	0.024 λ , 19.85 Ω	W1 = 4.064, W2 = 4.064, W3 = 2.032	W1 = 160, W2 = 160, W3 = 80
TL217	0.026 λ , 19.85 Ω	W1 = 4.064, W2 = 4.064, W3 = 2.286	W1 = 160, W2 = 160, W3 = 90
TL218	0.116 λ , 19.85 Ω	W = 4.064, L = 10.008	W = 160, L = 394
TL219	0.052 λ , 19.85 Ω	W = 4.064, L = 4.470	W = 160, L = 176
TL220	0.116 λ , 19.85 Ω	W = 4.064, L = 10.008	W = 160, L = 394
TL221	0.024 λ , 19.85 Ω	W1 = 4.064, W2 = 4.064, W3 = 2.032	W1 = 160, W2 = 160, W3 = 80
TL222	0.026 λ , 19.85 Ω	W1 = 4.064, W2 = 4.064, W3 = 2.286	W1 = 160, W2 = 160, W3 = 90
TL223	0.026 λ , 19.85 Ω	W1 = 4.064, W2 = 4.064, W3 = 2.286	W1 = 160, W2 = 160, W3 = 90
TL224	0.026 λ , 19.85 Ω	W1 = 4.064, W2 = 4.064, W3 = 2.286	W1 = 160, W2 = 160, W3 = 90
TL225	0.024 λ , 19.85 Ω	W1 = 4.064, W2 = 4.064, W3 = 2.032	W1 = 160, W2 = 160, W3 = 80
TL226	0.052 λ , 19.85 Ω	W = 4.064, L = 4.470	W = 160, L = 176
TL227		W1 = 0.001, W2 = 13.335, Offset = 6.223	W1 = 1, W2 = 525, Offset = 245

Reference Circuit (cont.)

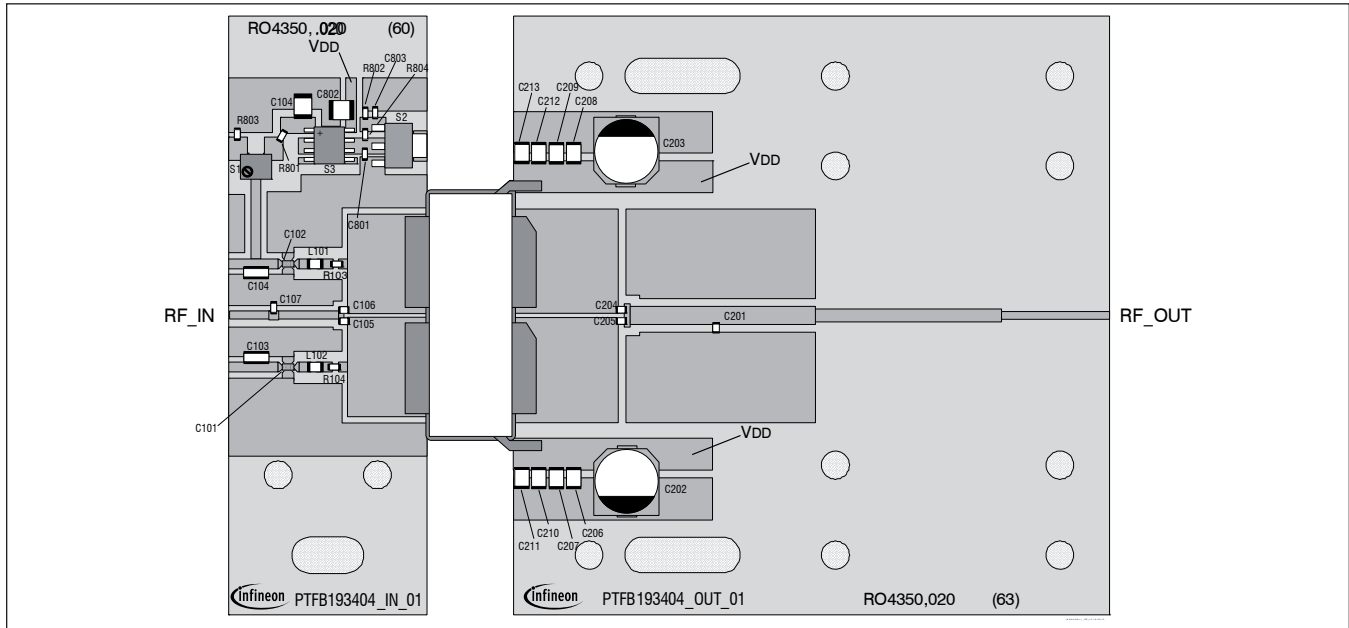

Reference circuit assembly diagram (not to scale)

Component ID	Description	Suggested Manufacturer	P/N
C101, C102	Chip capacitor, 1 μ F	ATC	NFM18PS105R0J30
C103, C104	Capacitor, 10 μ F	Digi-Key	490-4393-2-ND
C105, C106, C204, C205	Capacitor, 18 pF	ATC	800A180JT
C107	Capacitor, 1.5 pF	ATC	800A1R5BT
C801	Capacitor, 1 μ F	Digi-Key	490-4736-2-ND
C802, C804	Capacitor, 10 μ F	Digi-Key	587-1818-2-ND
C803	Chip capacitor, 1000 pF	Digi-Key	PCC1772CT-ND
L101, L102	Inductor, 22 nH	Digi-Key	0805W220JT
R101, R102	Resistor, 1000 Ω	Digi-Key	P1.0KECT-ND
R103, R104	Resistor, 10 Ω	Digi-Key	P10GTR-ND
R801	Resistor, 100 Ω	Digi-Key	P100GTR-ND
R802	Resistor, 1300 Ω	Digi-Key	P1.3KGTR-ND
R803	Resistor, 10 Ω	Digi-Key	P101GTR-ND
R804	Resistor, 1200 Ω	Digi-Key	P1.2KGTR-ND
S1	Potentiometer	Digi-Key	3224W-202ECT-ND
S2	Transistor	Digi-Key	BCP56-ND, BCP56
S3	Voltage regulator	Digi-Key	LM780L05ACM-ND, 7805
C201	Capacitor, 0.8 pF	ATC	800A0R8BT
C202, C203	Capacitor, 100 μ F	Digi-Key	PCE4442TR-ND
C206, C207, C208, C209	Capacitor, 4.7 μ F	Digi-Key	490-1864-2-ND
C210, C211, C212, C213	Capacitor, 10 μ F	Digi-Key	587-1818-2-ND

Pinout Diagram

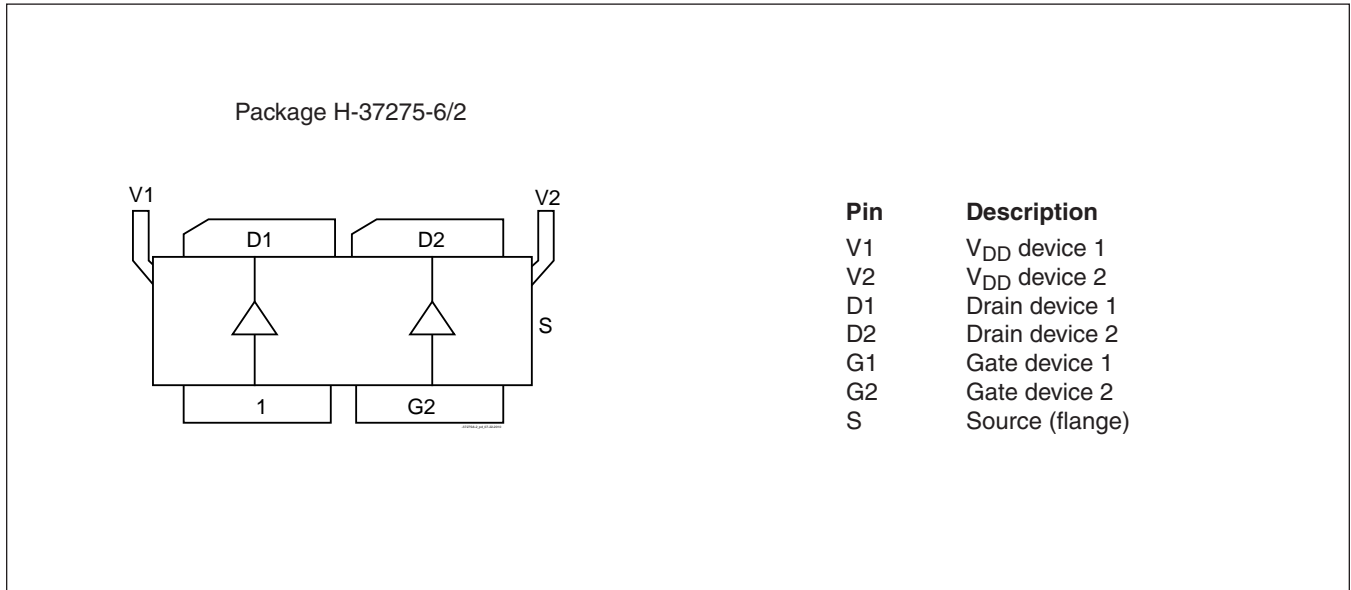

See next page for package outline specifications

Package Outline Specifications

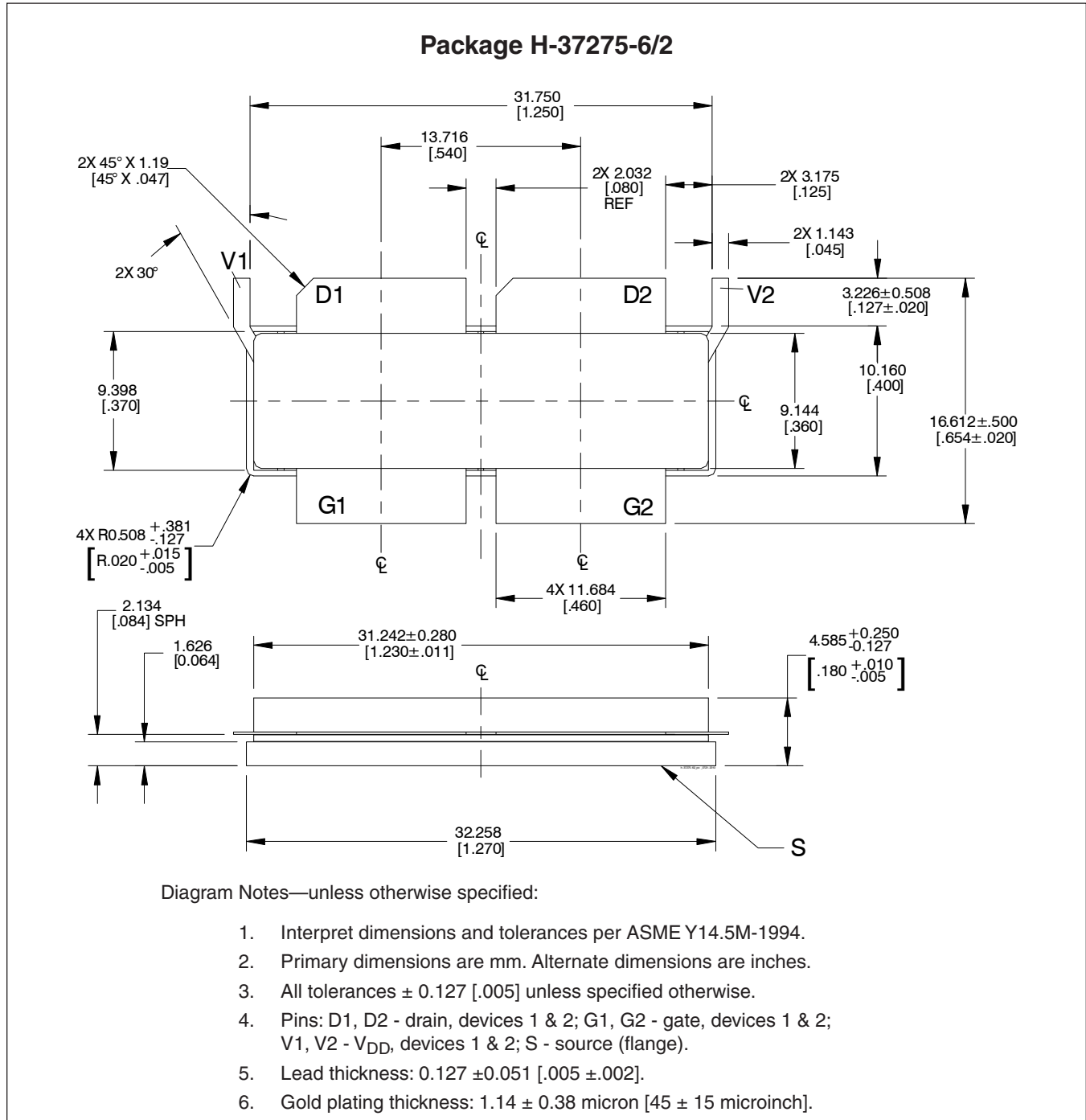

Find the latest and most complete information about products and packaging at the Infineon Internet page <http://www.infineon.com/rfpower>

Revision History: 2011-01-24

Previous Version: 2010-12-16, Data Sheet

Page	Subjects (major changes since last revision)
1, 2	RF tables revised for clarity.

We Listen to Your Comments

Any information within this document that you feel is wrong, unclear or missing at all?
 Your feedback will help us to continuously improve the quality of this document.
 Please send your proposal (including a reference to this document) to:

highpowerRF@infineon.com

To request other information, contact us at:
 +1 877 465 3667 (1-877-GO-LDMOS) USA
 or +1 408 776 0600 International

**Edition 2011-01-24**

Published by
Infineon Technologies AG
81726 Munich, Germany

© 2010 Infineon Technologies AG
All Rights Reserved.

Legal Disclaimer

The information given in this document shall in no event be regarded as a guarantee of conditions or characteristics. With respect to any examples or hints given herein, any typical values stated herein and/or any information regarding the application of the device, Infineon Technologies hereby disclaims any and all warranties and liabilities of any kind, including without limitation, warranties of non-infringement of intellectual property rights of any third party.

Information

For further information on technology, delivery terms and conditions and prices, please contact the nearest Infineon Technologies Office (www.infineon.com/rfpower).

Warnings

Due to technical requirements, components may contain dangerous substances. For information on the types in question, please contact the nearest Infineon Technologies Office.

Infineon Technologies components may be used in life-support devices or systems only with the express written approval of Infineon Technologies, if a failure of such components can reasonably be expected to cause the failure of that life-support device or system or to affect the safety or effectiveness of that device or system. Life support devices or systems are intended to be implanted in the human body or to support and/or maintain and sustain and/or protect human life. If they fail, it is reasonable to assume that the health of the user or other persons may be endangered.