

CB TRANSCEIVER TX FINAL AMPLIFIER APPLICATION.
HF TRANSCEIVER APPLICATION.

FEATURES

- Recommended for Output Stage Application of AM 4W Transmitter.
- High Power Gain.
- Wide Area of Safe Operation.

MAXIMUM RATING (Ta=25°C)

CHARACTERISTIC	SYMBOL	RATING	UNIT
Collector-Base Voltage	V_{CBO}	80	V
Collector-Emitter Voltage ($R_{BE}=50\Omega$)	V_{CER}	80	V
Emitter-Base Voltage	V_{EBO}	4	V
Collector Current	I_C	4	A
Emitter Current	I_E	-4	A
Collector Power Dissipation ($T_c=25^\circ\text{C}$)	P_C	10	W
Junction Temperature	T_j	150	°C
Storage Temperature Range	T_{stg}	-55 ~ 150	°C

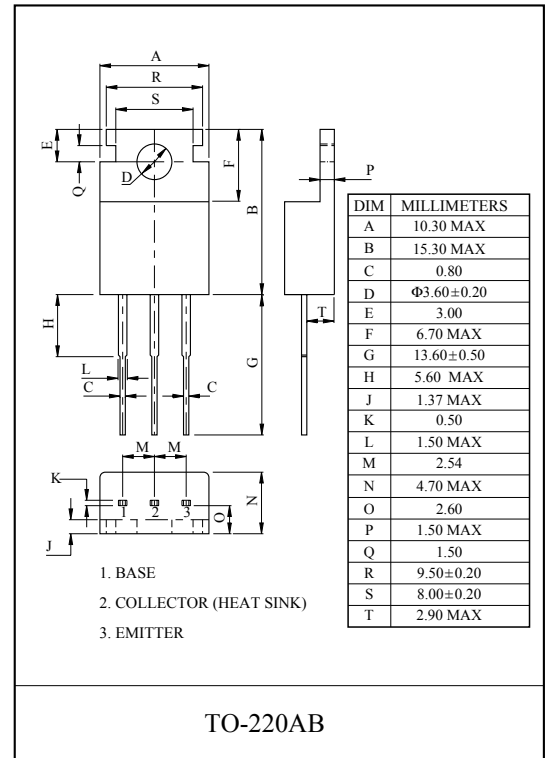

ELECTRICAL CHARACTERISTICS (Ta=25°C)

CHARACTERISTIC	SYMBOL	TEST CONDITION	MIN.	TYP.	MAX.	UNIT	
Collector Cut-off Current	I_{CBO}	$V_{CB}=30V, I_E=0$	-	-	10	μA	
Breakdown Voltage	Collector-Emitter	$V_{(BR)CER}$	$I_C=10\text{mA}, R_{BE}=50\Omega$	80	-	-	V
	Emitter-Base	$V_{(BR)EBO}$	$I_E=1.0\text{mA}, I_C=0$	4	-	-	V
DC Current Gain	h_{FE}	$V_{CE}=5V, I_C=0.5A$	100	-	200		
Collector-Emitter Saturation Voltage	$V_{CE(sat)}$	$I_C=3A, I_B=0.3A$	-	-	1.5	V	
Transition Frequency	f_T	$V_{CE}=5V, I_C=500\text{mA}$	100	-	-	MHz	
Collector Output Capacitance	C_{ob}	$V_{CB}=10V, I_E=0, f=1\text{MHz}$	-	40	-	pF	
Output Power (Fig.1)	P_o	$V_{CC}=12V, P_i=0.3W, f=27\text{MHz}$	4	-	-	W	

Fig. 1 P_o TEST CIRCUIT

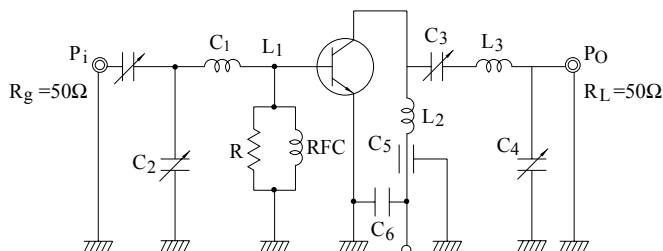

$C_1: \sim 100\text{pF}, C_2, C_3: \sim 150\text{pF}, C_4: \sim 300\text{pF}, C_5: 1000\text{pF}$

$C_6: 0.01\mu\text{F}, R: 250\Omega$

$L_1: 0.8\text{mm } \phi \text{ UEW, 7T, 8mm I.D. } L_2: 0.8\text{mm } \phi \text{ UEW, 5T, 8mm I.D.}$

$L_3: 0.8\text{mm } \phi \text{ UEW, 10T, 8mm I.D. RFC: 0.35mm } \phi \text{ UEW, 17T, 5mm I.D.}$

Fig.2 27MHz 4W OUTPUT AM TRANSCEIVER CIRCUIT

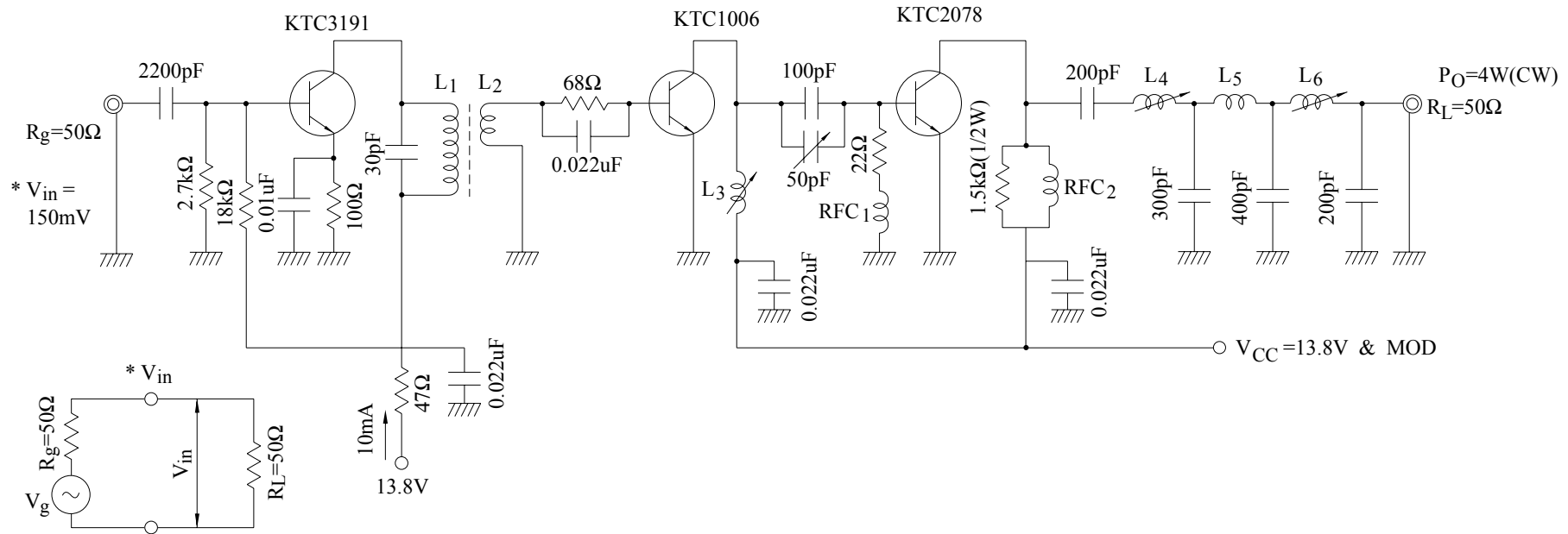

- L_1 : 4mm Φ BOBBIN WITH FERRITE CORE, 0.08mm Φ UEW, 8 TURNS
 L_2 : 4mm Φ BOBBIN WITH FERRITE CORE, 0.08mm Φ UEW, 2 TURNS
 L_3, L_6 : 6.5mm Φ BOBBIN WITH FERRITE CORE, 0.6mm Φ Sn PLATED COPPER WIRE $6\frac{1}{2}$ TURNS
 L_4 : 6.5mm Φ BOBBIN WITH FERRITE CORE, 0.6mm Φ Sn PLATED COPPER WIRE $8\frac{1}{2}$ TURNS
 L_5 : 0.6mm Φ Sn PLATED COPPER WIRE, 6.5mm I.D, $8\frac{1}{2}$ TURNS
 RFC₁ : 4.7 μ H, 7BA-480k (TOKO) RESISTOR : 1/4W CARBON
 RFC₂ : 0.2mm Φ UEW, 30 TURNS CAPACITOR : CERAMIC

KTC2078

$P_O - P_i$

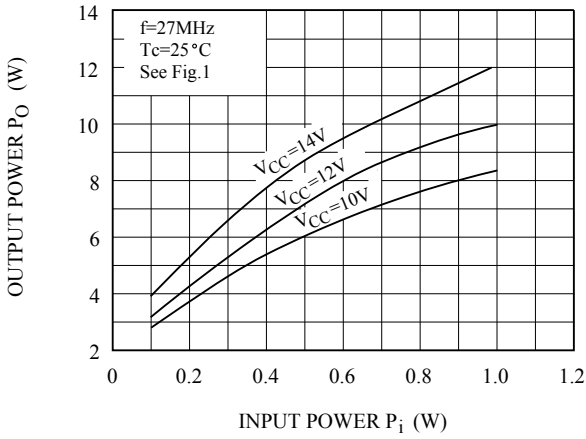

$P_O - V_{CC}$

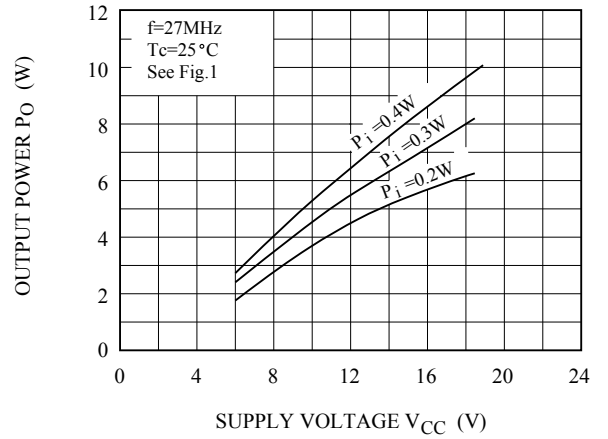

$h_{FE} - I_C$

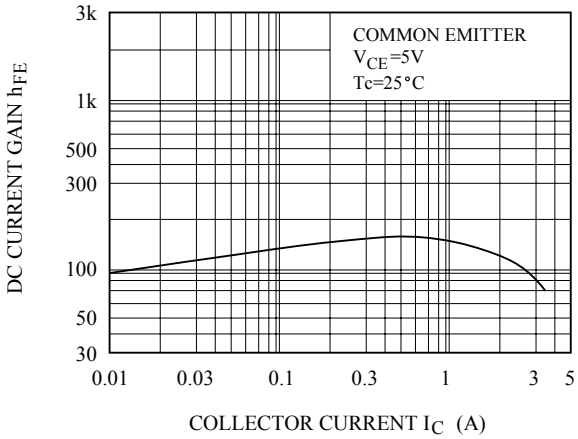

$f_T - I_C$

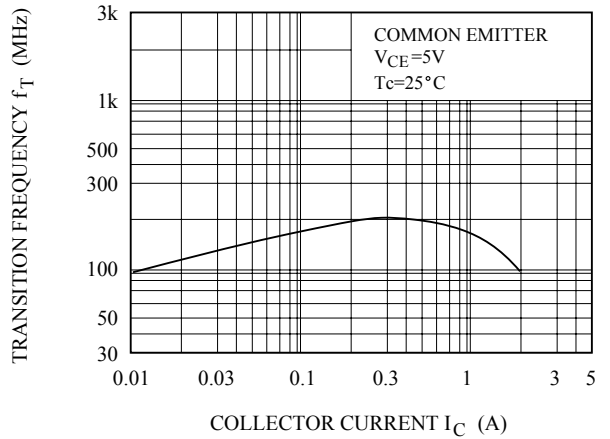

$C_{ob} - V_{CB}$

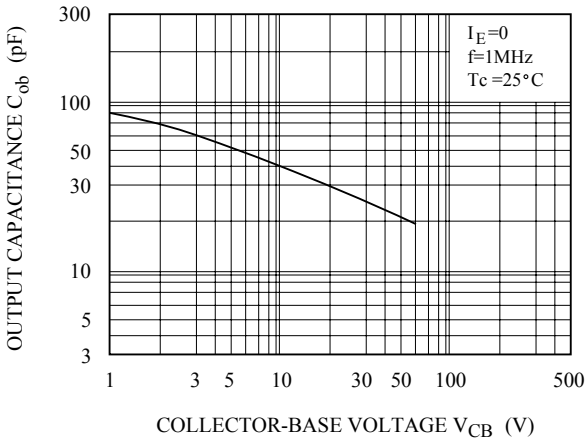

$P_c - T_a$

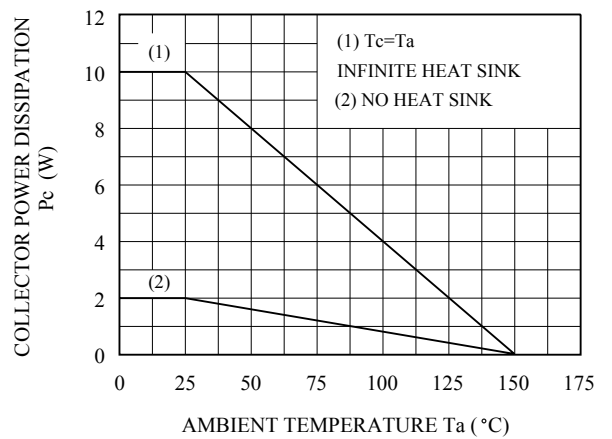

KTC2078

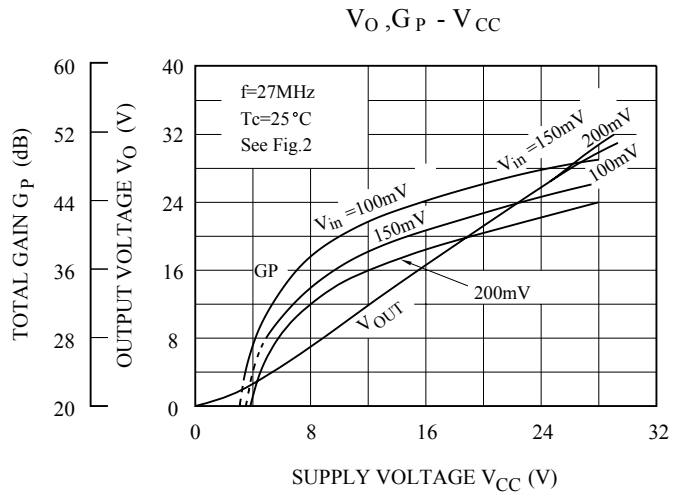
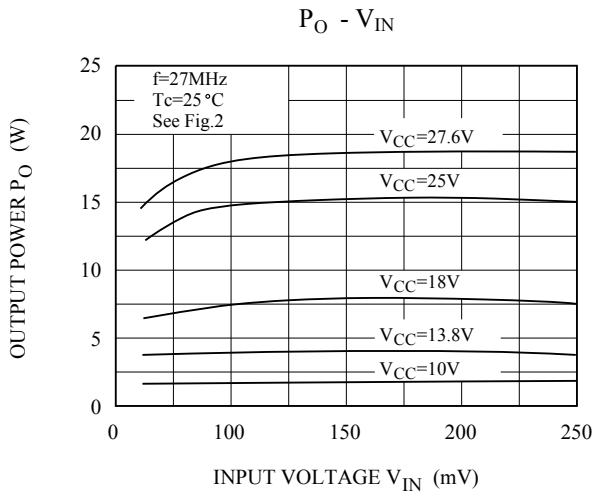

80% MODULATION SPECTRUM
EMISSION LIMITATION (FCC)

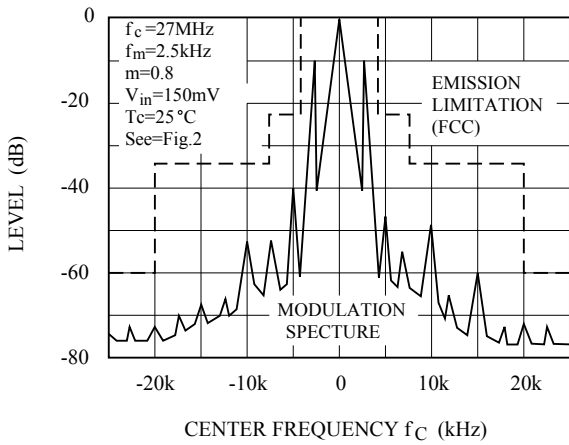

85% MODULATION SPECTRUM
EMISSION LIMITATION (FCC)

