



AWT6308R
 PCS/CDMA 3.4V/28dBm
 Linear Power Amplifier Module
 PRELIMINARY DATA SHEET - Rev 1.0

FEATURES

- InGaP HBT Technology
- High Efficiency:
 - 19 % @ +16 dBm output
 - 40 % @ +28 dBm output
- Low Quiescent Current: 16 mA
- Low Leakage Current in Shutdown Mode: <1 μ A
- Internal Voltage Regulation
- Optimized for a 50 Ω System
- Low Profile Miniature Surface Mount Package: 1 mm
- CDMA 1XRTT, 1xEV-DO Compliant
- Pinout Enables Easy Phone Board Migration From 4 mm x 4 mm Package
- RoHS-Compliant Package, 250 $^{\circ}$ C MSL-3

APPLICATIONS

- CDMA Wireless Handsets and Data Devices

PRODUCT DESCRIPTION

The AWT6308R meets the increasing demands for higher efficiency and smaller footprint in CDMA 1X handsets. The package pinout was chosen to enable handset manufacturers to switch from a 4 mm x 4 mm PA module with few layout changes while reducing board area requirements by 44%. The AWT6308R uses ANADIGICS' exclusive InGaP-Plus™ technology, which combines HBT and pHEMT devices on the same die, to enable state-of-the-art reliability, temperature stability, and ruggedness. The AWT6308R is part of ANADIGICS' High-Efficiency-at-Low-Power (HELP™) family of CDMA power amplifiers, which deliver low quiescent currents and significantly greater efficiency without a costly external DAC or DC-DC converter. Through selectable bias modes, the AWT6308R achieves optimal efficiency across different output power levels, specifically at low- and mid-range power levels where the PA typically operates, thereby dramatically increasing handset talk-time and standby-time. Its built-in voltage regulator eliminates the need for external voltage regulation components. The 3 mm x 3 mm x 1 mm surface mount package incorporates matching networks optimized for output power, efficiency, and linearity in a 50 Ω system.

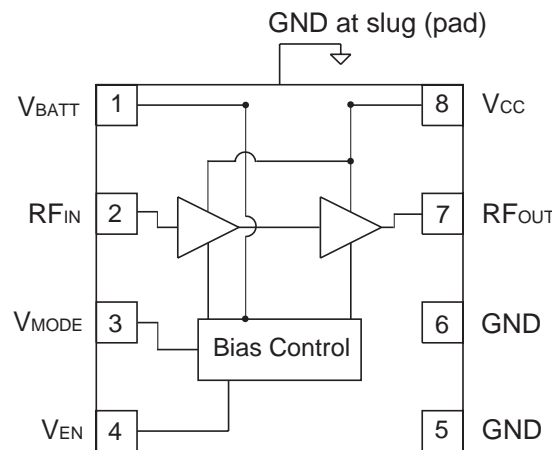
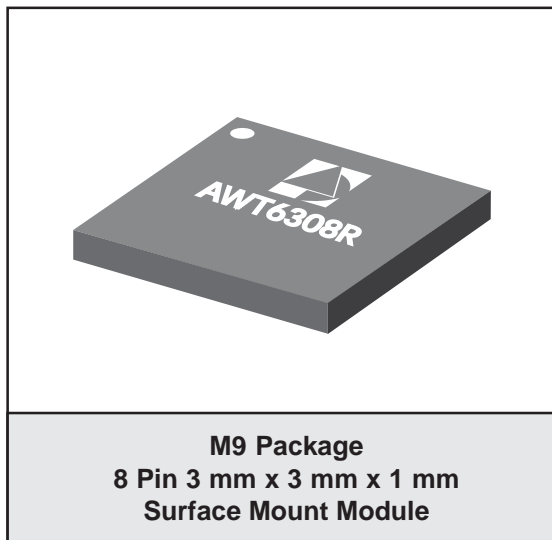

Figure 1: Block Diagram

AWT6308R

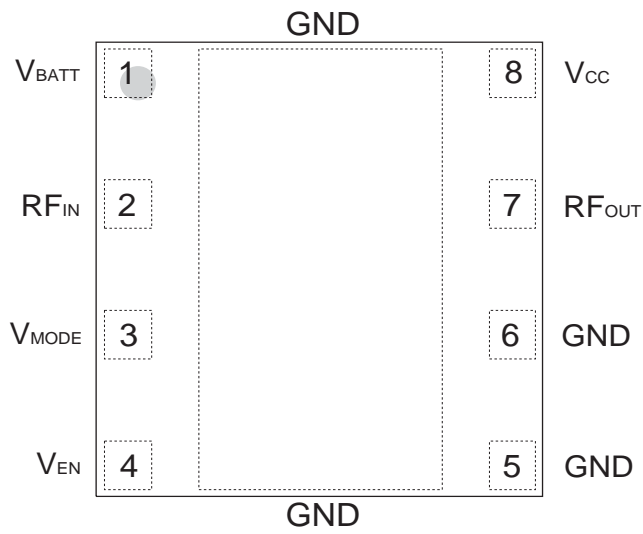

Figure 2: Pinout (X-ray Top View)

Table 1: Pin Description

PIN	NAME	DESCRIPTION
1	V _{BATT}	Battery Voltage
2	RF _{IN}	RF Input
3	V _{MODE}	Mode Control Voltage
4	V _{EN}	PA Enable Voltage
5	GND	Ground
6	GND	Ground
7	RF _{OUT}	RF Output
8	V _{CC}	Supply Voltage

ELECTRICAL CHARACTERISTICS

Table 2: Absolute Minimum and Maximum Ratings

PARAMETER	MIN	MAX	UNIT
Supply Voltage (V_{CC} and V_{BATT})	0	+5	V
Mode Control Voltage (V_{MODE})	0	+3.5	V
Enable Voltage (V_{EN})	0	+3.5	V
RF Input Power (P_{IN})	-	+10	dBm
Storage Temperature (T_{STG})	-40	+150	°C

Stresses in excess of the absolute ratings may cause permanent damage. Functional operation is not implied under these conditions. Exposure to absolute ratings for extended periods of time may adversely affect reliability.

Table 3: Operating Ranges

PARAMETER	MIN	TYP	MAX	UNIT	COMMENTS
Operating Frequency (f)	1850	-	1910	MHz	
Supply Voltage (V_{CC} and V_{BATT})	+3.2	+3.4	+4.2	V	
Enable Voltage (V_{EN})	+2.2 0	+2.4 -	+3.1 +0.5	V	PA "on" PA "shut down"
Mode Control Voltage (V_{MODE})	+2.2 0	+2.4 -	+3.1 +0.5	V	Low Bias Mode High Bias Mode
RF Output Power (P_{OUT})	27.5 ⁽¹⁾	+28.0	-	dBm	
Case Temperature (T_C)	-30	-	+85	°C	

The device may be operated safely over these conditions; however, parametric performance is guaranteed only over the conditions defined in the electrical specifications.

Notes:

(1) For operation at $V_{CC} = +3.2$ V, P_{OUT} is derated by 0.5 dB.

AWT6308R

Table 4: Electrical Specifications - CDMA Operation
(T_C = +25 °C, V_{BATT} = V_{CC} = +3.4 V, V_{EN} = +2.4 V, 50 Ω system)

PARAMETER	MIN	TYP	MAX	UNIT	COMMENTS
Gain	25 14 14	27 16 16	29 18 18	dB	P _{OUT} = +28 dBm, V _{MODE} = 0 V P _{OUT} = +16 dBm, V _{MODE} = +2.4 V P _{OUT} = +18 dBm, V _{MODE} = +2.4 V, V _{CC} = +3.7 V
Adjacent Channel Power at ±1.25 MHz offset Primary Channel BW - 1.23 MHz Adjacent Channel BW = 30 kHz	- - -	-51 -58 -52	-47 -47 -47	dBc	P _{OUT} = +28 dBm, V _{MODE} = 0 V P _{OUT} = +16 dBm, V _{MODE} = +2.4 V P _{OUT} = +18 dBm, V _{MODE} = +2.4 V, V _{CC} = +3.7 V
Adjacent Channel Power at ±2.25 MHz offset Primary Channel BW - 1.23 MHz Adjacent Channel BW = 30 kHz	- -	-62 -62	-57 -57	dBc	P _{OUT} = +28 dBm, V _{MODE} = 0 V P _{OUT} = +16 dBm, V _{MODE} = +2.4 V
Power-Added Efficiency	37 16	40 19	- -	%	P _{OUT} = +28 dBm, V _{MODE} = 0 V P _{OUT} = +16 dBm, V _{MODE} = +2.4 V
Quiescent Current (I _q)	-	14	20	mA	through V _{CC} pin, V _{MODE} = +2.4 V
Enable Current	-	0.3	0.8	mA	through V _{EN} pin, PA "on"
Mode Control Current	-	0.3	0.8	mA	through V _{MODE} pin, V _{MODE} = +2.4 V
Battery Current	-	3	5	mA	through V _{BATT} pin, V _{MODE} = +2.4 V
Leakage Current	-	<1	5	μA	V _{CC} = +4.2 V, V _{EN} = 0 V, V _{MODE} = 0 V
Noise in Receive Band	-	-135	-133	dBm/Hz	1930 MHz to 1990 MHz
Harmonics 2fo 3fo, 4fo	- -	-43 -55	-30 -30	dBc	
Input Impedance	-	-	2:1	VSWR	
Spurious Output Level (all spurious outputs)	-	-	-65	dBc	P _{OUT} ≤ +28 dBm In-band load VSWR < 5:1 Out-of-band load VSWR < 10:1 Applies over all operating ranges
Load mismatch stress with no permanent degradation or failure	8:1	-	-	VSWR	Applies over full operating range

Notes:

1. ACPRs and Efficiency Limits at mid-band only.

APPLICATION INFORMATION

To ensure proper performance, refer to all related Application Notes on the ANADIGICS web site: <http://www.anadigics.com>

Shutdown Mode

The power amplifier may be placed in a shutdown mode by applying logic low levels (see Operating Ranges table) to both the V_{REF} and V_{MODE} voltages.

Bias Modes

The power amplifier may be placed in either a Low Bias mode or a High Bias mode by applying the appropriate logic level (see Operating Ranges table) to the V_{MODE} voltage. The Bias Control table lists the recommended modes of operation for various applications.

Table 5: Bias Control

APPLICATION	P_{OUT} LEVELS	LOGIC	V_{EN}	V_{MODE}
CDMA - low power	$\leq +16\text{dBm}$	Low	+2.4 V	+2.4 V
CDMA - high power	$> +16\text{ dBm}$	High	+2.4 V	0 V
Shutdown	-	Shutdown	0 V	0 V

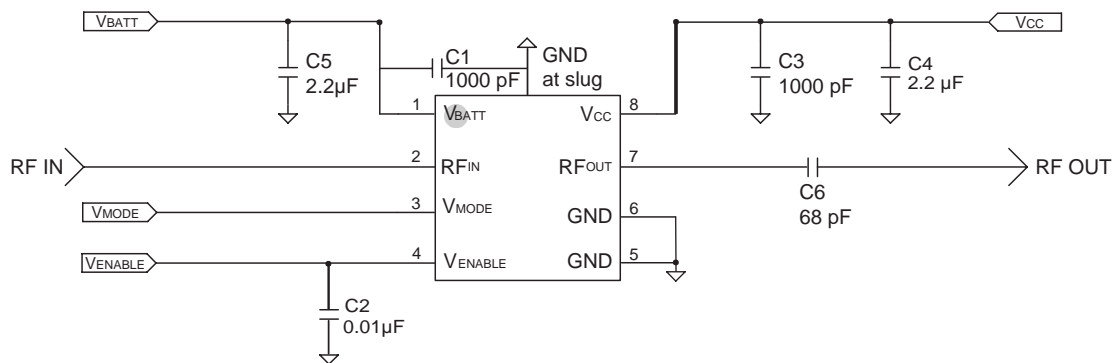
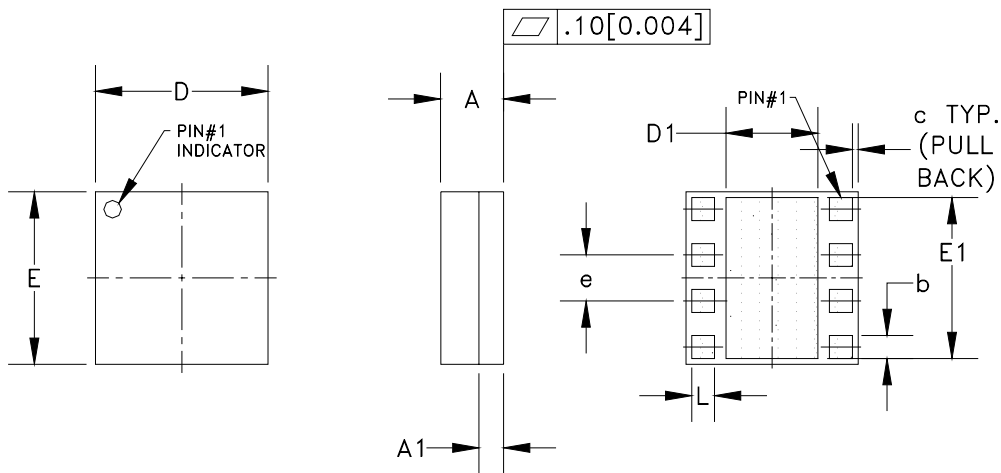

Figure 3: Application Circuit

AWT6308R

PACKAGE OUTLINE



Symbol	MILLIMETERS			INCHES			NOTE
	MIN.	NOM.	MAX.	MIN.	NOM.	MAX.	
A	0.90	1.00	1.10	0.035	0.039	0.043	-
A1	-	0.35	-	-	0.013	-	-
b	0.35	-	0.60	0.013	-	0.024	3
c	-	0.10	-	-	0.004	-	-
D	2.88	3.00	3.12	0.113	0.118	0.123	-
D1	1.20	-	1.50	0.047	-	0.060	3
E	2.88	3.00	3.12	0.113	0.118	0.123	-
E1	2.75	-	2.85	0.108	-	0.112	3
e	0.80 BSC			0.0315 BSC			-
L	0.35	-	0.60	0.013	-	0.024	3

NOTES:

1. CONTROLLING DIMENSIONS: MILLIMETERS
2. UNLESS SPECIFIED TOLERANCE=±0.076[0.003].
3. PADS (INCLUDING CENTER) SHOWN UNIFORM SIZE FOR REFERENCE ONLY. ACTUAL PAD SIZE AND LOCATION WILL VARY WITHIN MIN. AND MAX. DIMENSIONS ACCORDING TO SPECIFIC LAMINATE DESIGN.
4. UNLESS SPECIFIED DIMENSIONS ARE SYMMETRICAL ABOUT CENTER LINES SHOWN.

Figure 4: M9 Package Outline - 8 Pin 3 mm x 3 mm x 1 mm Surface Mount Module

TOP BRAND



NOTES:

1. ANADIGICS LOGO SIZE: NONE
2. PART NUMBER: FOUR DIGIT NUMERICAL
3. WAFER LOT NUMBER: LLLL = LOT NUMBER
NN = WAFER I.D.
4. PIN 1 INDICATOR: LASER DOT
5. B.O.M. # BBBB
6. COUNTRY CODE: CC = TH-for-THAILAND, TW-for-TAIWAN
CC = PH-for-PHILIPPINES, CH-for-CHINA
7. TYPE : ARIAL
SIZE : 1.5-POINT
COLOR : LASER

Figure 5: Branding Specification

COMPONENT PACKAGING

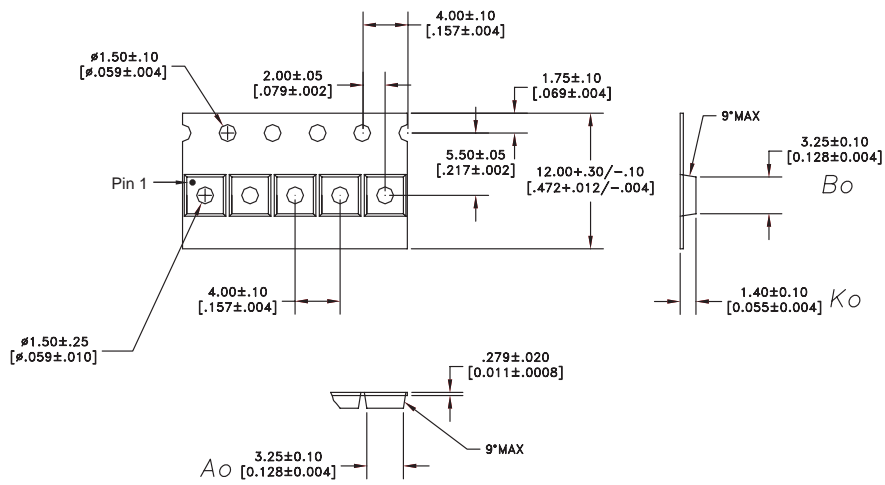

NOTES:

- 1. MATERIAL: 3000 (CARBON FILLED POLYCARBONATE)
100% RECYCLABLE.

DIMENSIONS ARE IN MILLIMETERS [INCHES]

DIMENSIONING AND TOLERANCING PER ASME Y14.5M-1994

Figure 6: Tape & Reel Packaging

Table 6: Tape & Reel Dimensions

PACKAGE TYPE	TAPE WIDTH	POCKET PITCH	REEL CAPACITY	MAX REEL DIA
3 mm x 3 mm x 1 mm	12 mm	4 mm	2500	7"

AWT6308R

ORDERING INFORMATION

ORDER NUMBER	TEMPERATURE RANGE	PACKAGE DESCRIPTION	COMPONENT PACKAGING
AWT6308RM9Q7	-30 °C to +85 °C	RoHS-Compliant 8 Pin 3 mm x 3 mm x 1 mm Surface Mount Module	Tape and Reel, 2500 pieces per Reel



ANADIGICS, Inc.

141 Mount Bethel Road
Warren, New Jersey 07059, U.S.A.
Tel: +1 (908) 668-5000
Fax: +1 (908) 668-5132

URL: <http://www.anadigics.com>
E-mail: Mktg@anadigics.com

IMPORTANT NOTICE

ANADIGICS, Inc. reserves the right to make changes to its products or to discontinue any product at any time without notice. The product specifications contained in Advanced Product Information sheets and Preliminary Data Sheets are subject to change prior to a product's formal introduction. Information in Data Sheets have been carefully checked and are assumed to be reliable; however, ANADIGICS assumes no responsibilities for inaccuracies. ANADIGICS strongly urges customers to verify that the information they are using is current before placing orders.

WARNING

ANADIGICS products are not intended for use in life support appliances, devices or systems. Use of an ANADIGICS product in any such application without written consent is prohibited.