

# Electronics Meets the Challenges of Patient Monitors

The medical industry is keeping pace with other major markets in terms of integration. Single units such as blood pressure cuffs, ECGs and oxygen sensors have successfully entered consumer markets, but there is increasing interest in patient monitors, which encompass all of those monitoring abilities and more.

The medical market is generally grouped into three major subcategories: home, clinical and imaging. Home medical is predominately lower cost, portable equipment that has lower performance requirements. Clinical and hospital grade equipment is generally higher performance and therefore more expensive. Imaging systems are generally very large mainframe bases systems, with the exception of ultrasound, that is rapidly expanding into portable and cart-based systems.

Fundamentally, most of these systems are analog sensor measurement systems, but applied to biometric functions, such as blood pressure, body temperature or heart rate. These biometric sensors are designed to measure physical events, such as temperature, pressure, light and flow. After measurement, the system converts them into a corresponding voltage or current. The signal is then conditioned and digitized for processing and analysis. On the control side, the signal is converted back to a current or voltage and applied to an actuator to control such things as air flow, oxygen or temperature.

A typical high end patient monitor system has 5 basic subsystems: ECG, pulse oximetry, blood pressure, body temperature and respiration. Typically the most critical components in each system are the sensor circuits.

Each module uses a different sensor and signal conditioning circuit. For example, the ECG uses electrodes to measure the electric pulse from the heart. The pulse oximetry (SpO2) uses a light-emitting diode and light sensor to measure oxygen content. Blood pressure is typically measured using a

piezo-resistive pressure transducer. For simplicity, several of these biometric modules may utilize common digital, power and IO subsystems.

## Blood Pressure

In blood pressure biometric modules, the most critical function is the pressure sensor circuit. Here precision amplifiers are used to detect very small signals from the transducer and amplify them to a level suitable for ADC processing. This is typically followed by an active filter to limited unwanted noise at higher frequencies. Amplifiers with low noise, low drift and high gain are necessary to minimize measurement errors and ensure accurate readings. See Figure 2 for a system block diagram.

Most commonly used piezo-resistive silicon pressure sensor in medical applications is the Wheatstone bridge. The pressure sensing element combines resistors and an etched diaphragm structure to provide an electrical signal that changes with pressure. As the diaphragm moves under pressure, stress is concentrated in specific areas of the silicon element. The result is a small voltage that changes proportional to the pressure applied to the diaphragm. This bridge signal is then amplified using precision op amps prior to ADC conversion.

Key questions to ask when recommending an amplifier are what is the required accuracy and what are the required voltages? Hospital grade equipment has different requirements than portable home based systems while pressure sensors have varying sensitivities and voltage requirements. The amplifier will generally be selected to match the requirement of the sensor. The ISL28127 and ISL28217 are excellent op amps for  $\pm 5V$  pressure sensor amp gain frontends due to their low noise and low DC offset and drift.

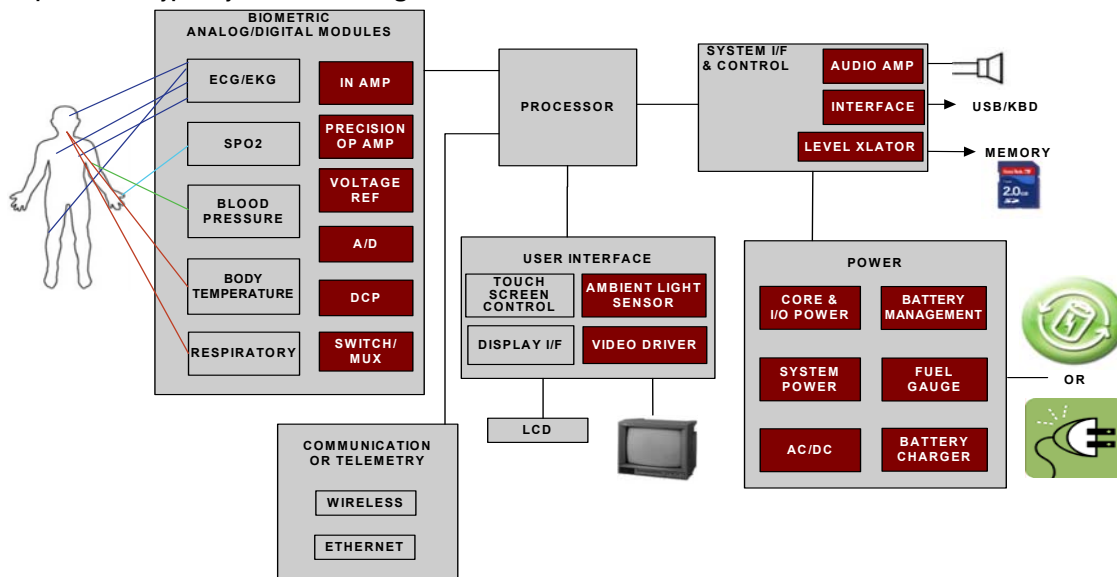

FIGURE 1. BLOCK DIAGRAM OF A PATIENT MONITOR

# Application Note 1690

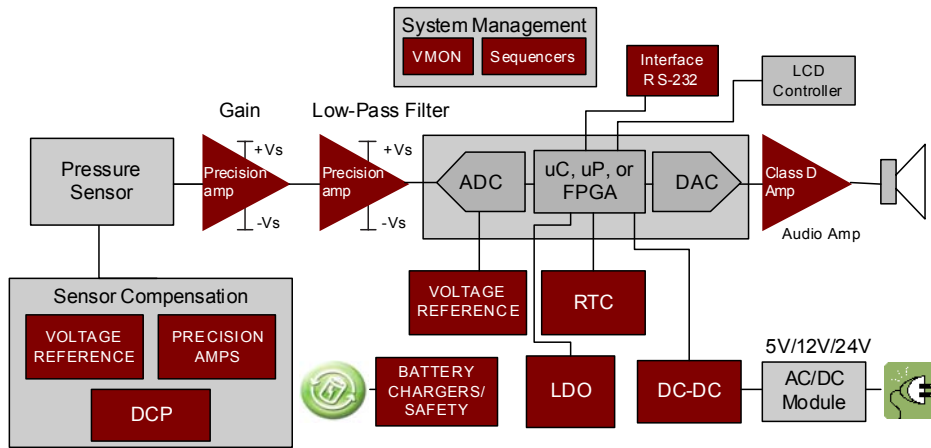

FIGURE 2. BLOCK DIAGRAM OF A BLOOD PRESSURE SYSTEM

## DIAGNOSTIC ECG MULTI-LEAD (e.g. 12-lead) [1 of n\* channels shown below]

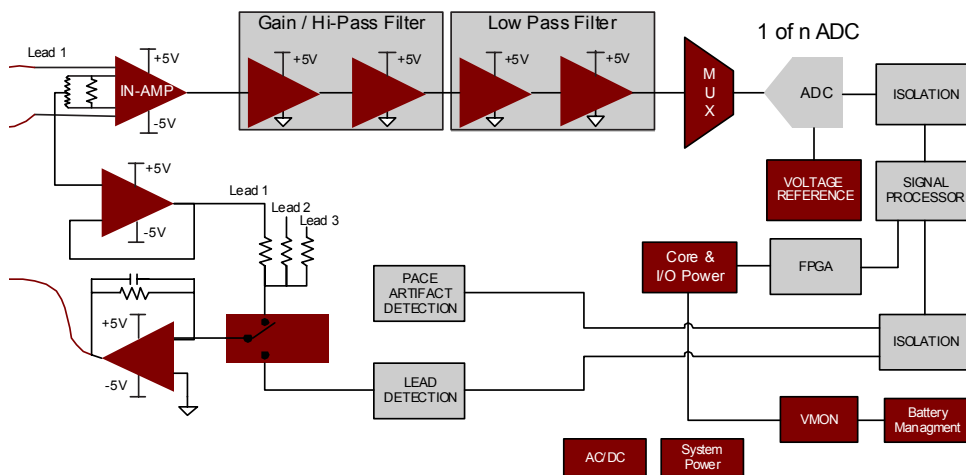

FIGURE 3. BLOCK DIAGRAM OF AN ECG SYSTEM

## Electrocardiogram (ECG)

There are several precision amplifier and instrumentation amplifier opportunities in ECG applications. Shown in Figure 3 is a diagnostic (or clinical) ECG with up to 12-leads. Key blocks for lead devices are the electrode gain amplifier, high pass filter (usually 0.5Hz), low pass filter (around 150Hz) and right leg drive feedback circuit. For ECG, each electrode requires a precision instrumentation amp to extract a very small signal that rides on a 300-700mV common mode voltage. Typically, this amplifier will use a higher supply voltage to enable a high gain without raiiling the amplifier in the presence of the high common mode voltage from the body. This can be a discrete instrumentation amp or an integrated instrumentation amplifier. Second and third stage active filter amplifiers are needed to set a very specific band (0.5Hz - 150Hz) to capture the ECG QRS wave signal. Typically, these will be low noise 5V amplifiers with good bandwidth. In

addition, low noise, low power amplifiers are needed for the right leg drive feedback function.

In multi-channel systems, such as a 12-lead ECG monitor, it is common to multiplex signals into a common ADC. The key requirements for the multiplexer (mux) are typically low on-resistance and low charge injection. Generally a specific mux is selected to match the voltage requirements of the filter amplifiers and the ADC. It is also common for multichannel ECGs to have automated lead detection to enable multi-configuration operations. Generally, a low on-resistance switch is used in this circuit as well.

Multiplexers like the ISL43681 and ISL43640 are excellent choices for medical devices as they can operate from 2V to 12V. In addition, they have low on-resistance of 39Ω to 60Ω, which lowers distortion and reduces kick-back voltage from the ADC. Their low charge injection of 0.3pC to 2pC reduces error

# Application Note 1690

contribution on charge redistribution ADCs. They are also low power and available in the very small QFN package.

For 3-lead portable ECG applications, low power instrumentation amps from a CMOS process may be a better selection. Since CMOS inputs naturally provide a high impedance input, the need for external buffers is eliminated, saving cost. A good choice for the input amplifier can deliver active feedback with a very precise base line compensation voltage, low  $1/f$  noise, extremely low offset and low drift versus temperature.

## Pulse Oximetry (SpO2)

Oxygen is carried in the blood in hemoglobin and is one of the key vital signs needing detection. Pulse oximetry takes advantage of the fact the blood absorbs certain wavelengths of light differently when it is oxygenated than when it is oxygen deprived.

The wavelength that marks the difference in absorption to identify oxygen concentration is approximately 805nm for adult hemoglobin. Therefore, we will use two other wavelengths—one above and one below to calculate the percentage of oxygenated red blood cells. Usually 660nm and 940nm are used. A high impedance, low bias current op amp is needed to process the photodiodes that receive the signal at these wavelengths. The

ADC also needs to have the fast throughput of a 16-bit device. The DC and background noise is subtracted out, and the pulsed signals are then scaled. Extensive over-sampling, filtering and signal processing are needed to eliminate noise, such as movement artifacts from the small signals, as well as allowing for the pulse rate to be measured.

## Conclusion

The medical market has developed enough to support the needs of a wide range of amplifiers, multiplexers, converters, references, interface products and power supply products. The portable instruments need lowest power and meticulous battery management above and beyond the stringent noise and gain requirements. The non-portable instruments need reliable isolation and patient protection in addition to their precise measurement capability.

It is difficult, if not impossible, to offer the best solution for all situations. Every trade-off of power consumption, available supplies, required resolution, portability, noise and more will play into the selection of the key components. Understanding the implications of device choice will ensure that your system safely delivers quality for the lifetime of the system.

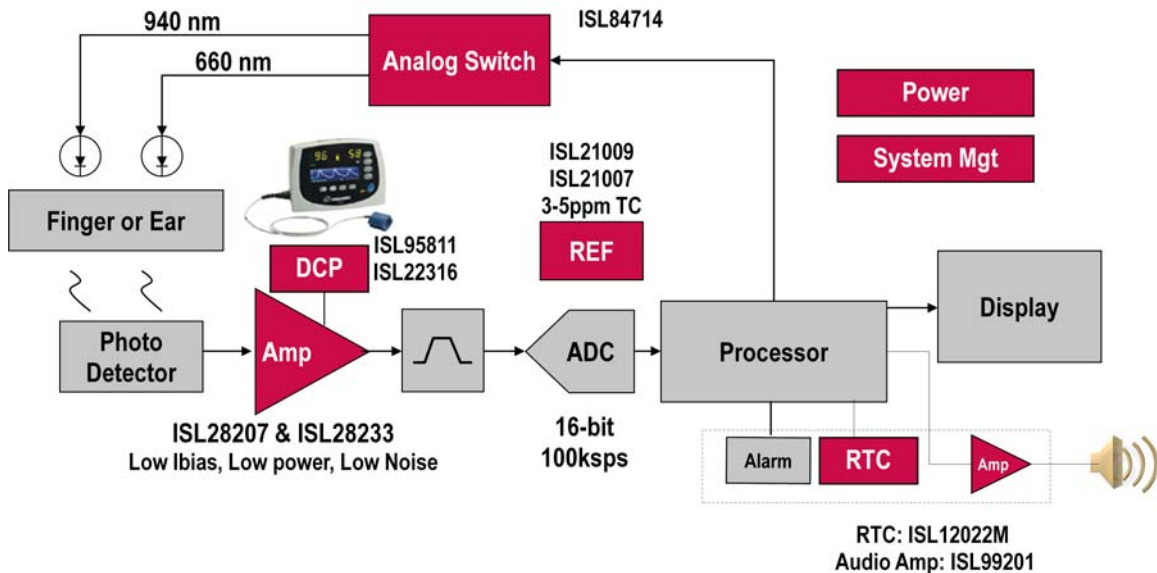

FIGURE 4. BLOCK DIAGRAM FOR PULSE OXIMETRY SYSTEM

Intersil Corporation reserves the right to make changes in circuit design, software and/or specifications at any time without notice. Accordingly, the reader is cautioned to verify that the Application Note or Technical Brief is current before proceeding.

For information regarding Intersil Corporation and its products, see [www.intersil.com](http://www.intersil.com)