

RoHS Compliant Product

Description

The SOT-89 package is universally preferred for all commercial industrial surface mount applications and suited for low voltage applications such as DC/DC converters.

SOT-89

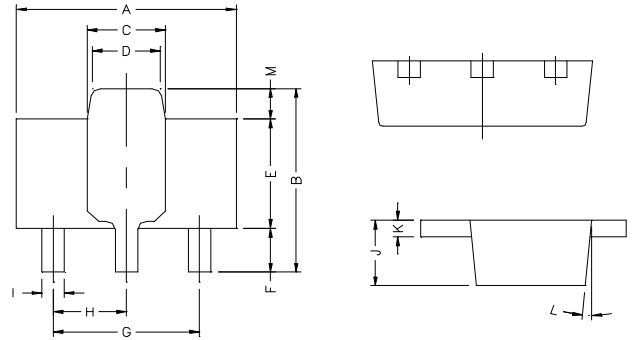

REF.	Millimeter		REF.	Millimeter	
	Min.	Max.		Min.	Max.
A	4.4	4.6	G	3.00	REF.
B	4.05	4.25	H	1.50	REF.
C	1.50	1.70	I	0.40	0.52
D	1.30	1.50	J	1.40	1.60
E	2.40	2.60	K	0.35	0.41
F	0.89	1.20	L	5° TYP.	
			M	0.70 REF.	

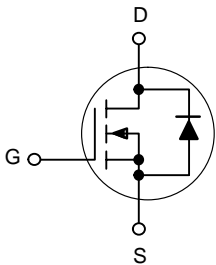

Marking :

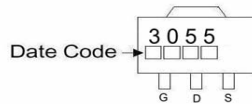

Absolute Maximum Ratings

Parameter	Symbol	Ratings	Unit
Drain-Source Voltage	V_{DS}	30	V
Gate-Source Voltage	V_{GS}	± 20	V
Continuous Drain Current, $V_{GS}@10V$	$I_D@T_A=25^\circ C$	15	A
Continuous Drain Current, $V_{GS}@10V$	$I_D@T_A=100^\circ C$	9	A
Pulsed Drain Current ¹	I_{DM}	50	A
Total Power Dissipation	$P_D@T_A=25^\circ C$	15	W
Operating Junction and Storage Temperature Range	T_j, T_{stg}	-55~+150	$^\circ C$

Thermal Data

Parameter	Symbol	Ratings	Unit
Thermal Resistance Junction-ambient	R_{thj-a}	42	$^\circ C/W$
Thermal Resistance Junction-case	R_{thj-c}	3	

Electrical Characteristics($T_j=25^\circ\text{C}$ Unless otherwise specified)

Parameter	Symbol	Min.	Typ.	Max.	Unit	Test Condition
Drain-Source Breakdown Voltage	BV_{DSS}	30	-	-	V	$V_{GS}=0V, I_D=250\mu A$
Breakdown Voltage Temp. Coefficient	$\Delta BV_{DS}/\Delta T_j$	-	0.037	-	V/ $^\circ\text{C}$	Reference to 25°C , $I_D=1mA$
Gate Threshold Voltage	$V_{GS(th)}$	1.0	-	3.0	V	$V_{DS}=V_{GS}, I_D=250\mu A$
Gate-Source Leakage Current	I_{GSS}	-	-	± 100	nA	$V_{GS}=\pm 20V$
Drain-Source Leakage Current ($T_j=25^\circ\text{C}$)	I_{DSS}	-	-	25	μA	$V_{DS}=30V, V_{GS}=0$
Drain-Source Leakage Current($T_j=150^\circ\text{C}$)		-	-	250	μA	$V_{DS}=24V, V_{GS}=0$
Static Drain-Source On-Resistance	$R_{DS(ON)}$	-	-	80	m Ω	$V_{GS}=10V, I_D=8A$
		-	-	100		$V_{GS}=4.5V, I_D=6A$
Total Gate Charge ²	Q_g	-	5.4	-	nC	$I_D=8A$ $V_{DS}=24V$ $V_{GS}=5V$
Gate-Source Charge	Q_{gs}	-	1.3	-		
Gate-Drain ("Miller") Charge	Q_{gd}	-	3.6	-		
Turn-on Delay Time ²	$T_{d(ON)}$	-	3.6	-	nS	$V_{DS}=15V$ $I_D=8A$ $V_{GS}=10V$ $R_G=3.4\Omega$ $R_D=1.9\Omega$
Rise Time	T_r	-	19.8	-		
Turn-off Delay Time	$T_{d(OFF)}$	-	13	-		
Fall Time	T_f	-	3.2	-		
Input Capacitance	C_{iss}	-	260	-	pF	$V_{GS}=0V$ $V_{DS}=25V$ $f=1.0MHz$
Output Capacitance	C_{oss}	-	144	-		
Reverse Transfer Capacitance	C_{rss}	-	13	-		

Source-Drain Diode

Parameter	Symbol	Min.	Typ.	Max.	Unit	Test Condition
Forward On Voltage ²	V_{SD}	-	-	1.3	V	$I_S=15A, V_{GS}=0V, T_j=25^\circ\text{C}$
Continuous Source Current(Body Diode)	I_S	-	-	15	A	$V_D=V_G=0V, V_S=1.3V$
Pulsed Source Current(Body Diode) ¹	I_{SM}	-	-	50	A	

Notes: 1.Pulse width limited by safe operating area.
2.Pulse width $\leq 300\mu s$, duty cycle $\leq 2\%$.

Characteristics Curve

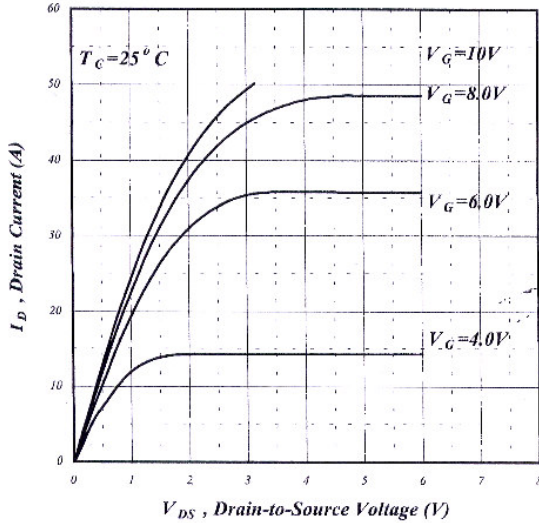

Fig 1. Typical Output Characteristics

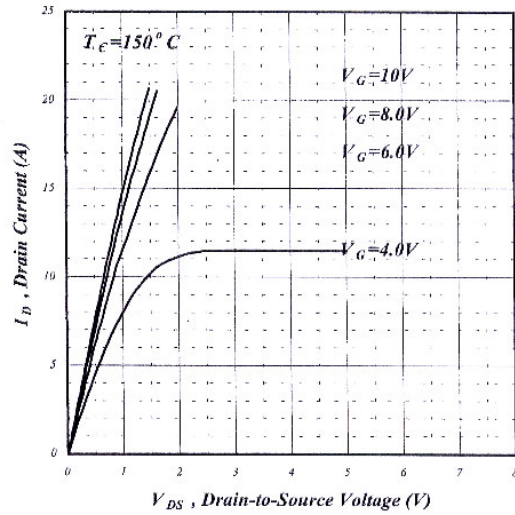

Fig 2. Typical Output Characteristics

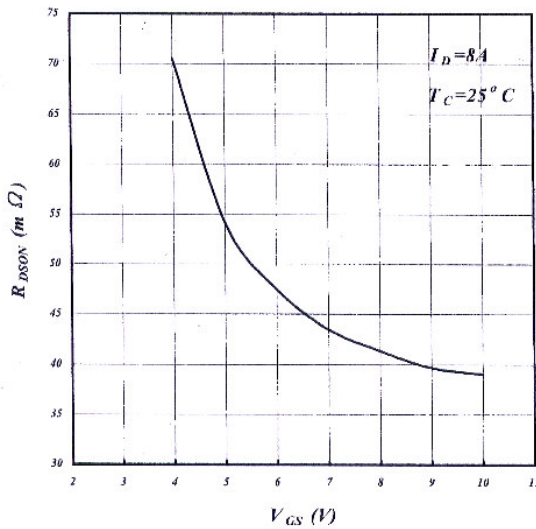

Fig 3. On-Resistance v.s. Gate Voltage

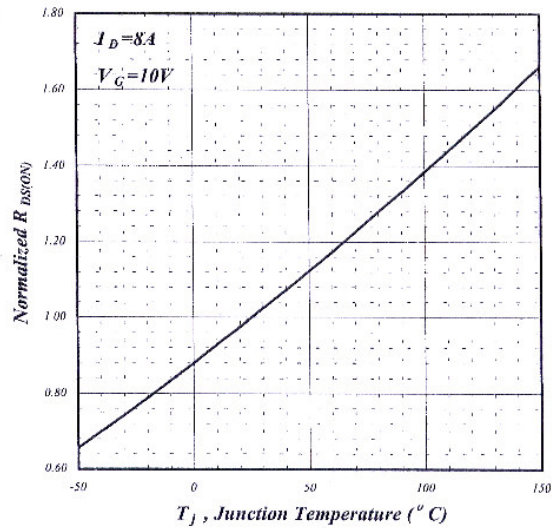

Fig 4. Normalized On-Resistance v.s. Junction Temperature

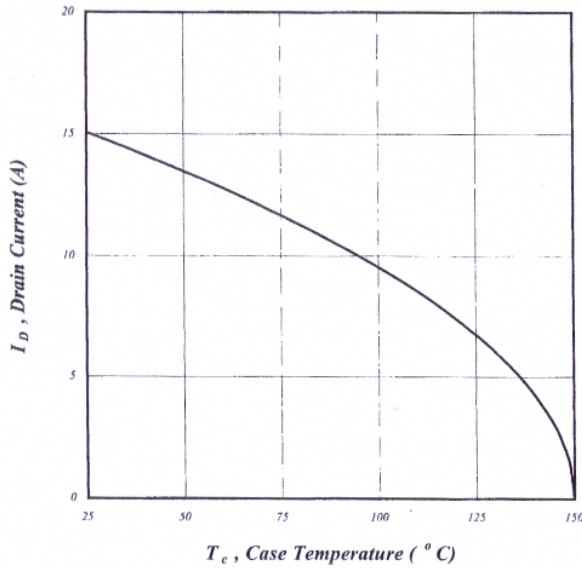

Fig 5. Maximum Drain Current v.s. Case Temperature

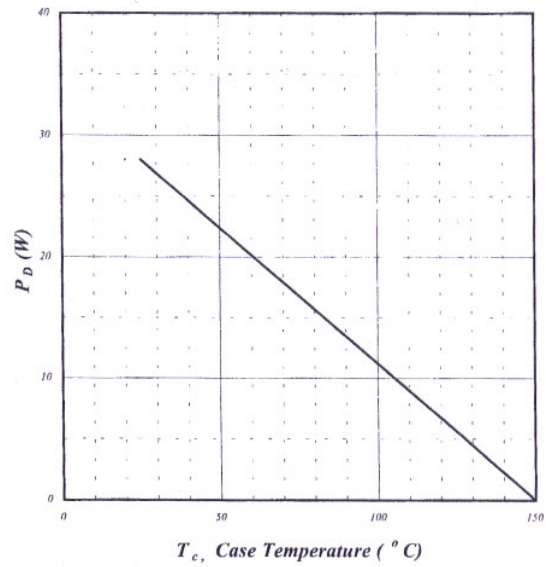

Fig 6. Typical Power Dissipation

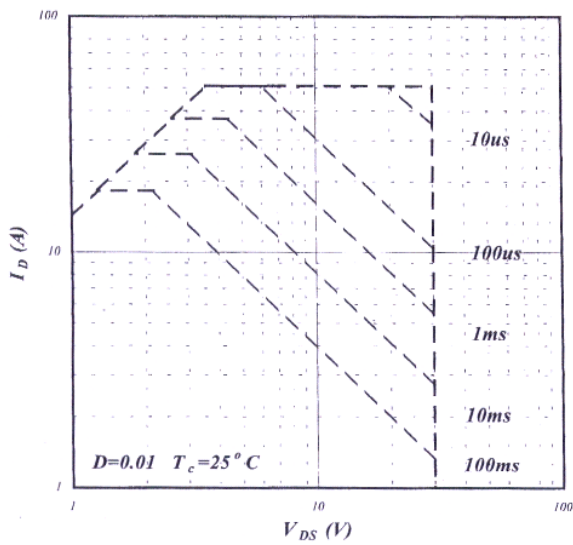

Fig 7. Maximum Safe Operating Area

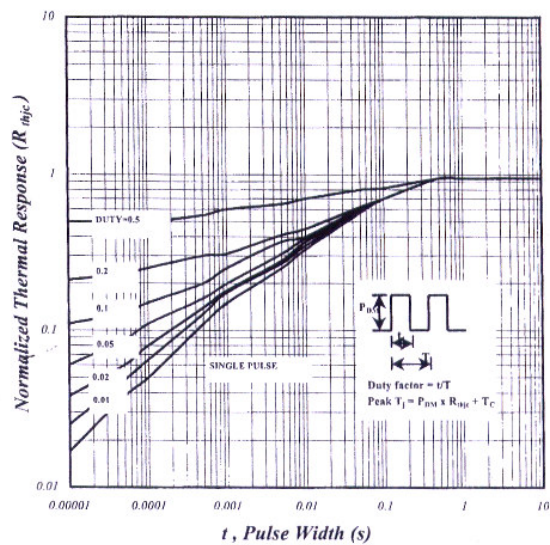

Fig 8. Effective Transient Thermal Impedance

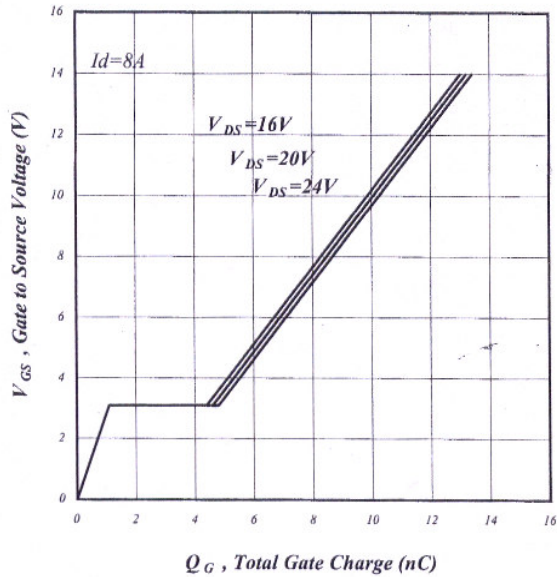

Fig 9. Gate Charge Characteristics

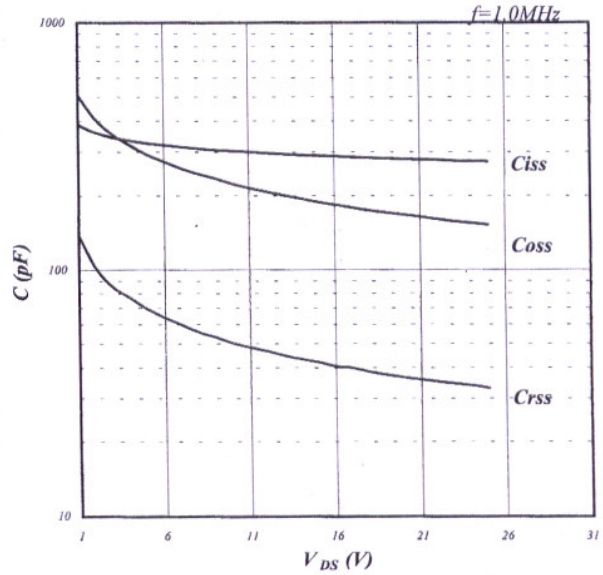

Fig 10. Typical Capacitance Characteristics

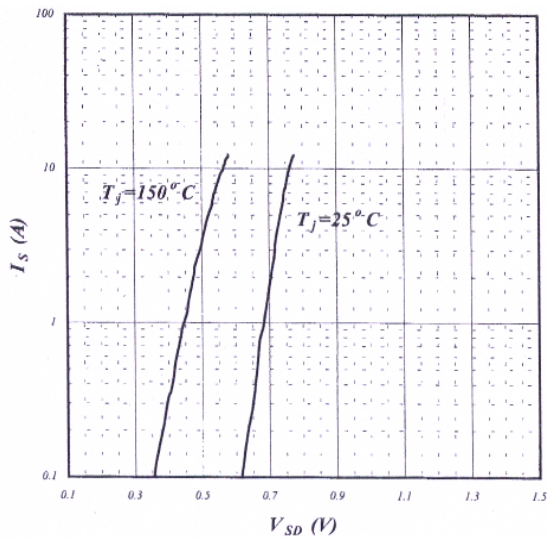

Fig 11. Forward Characteristic of Reverse Diode

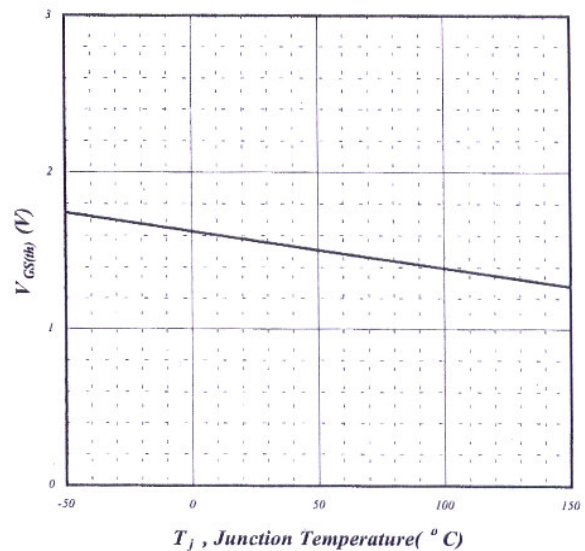

Fig 12. Gate Threshold Voltage v.s. Junction Temperature

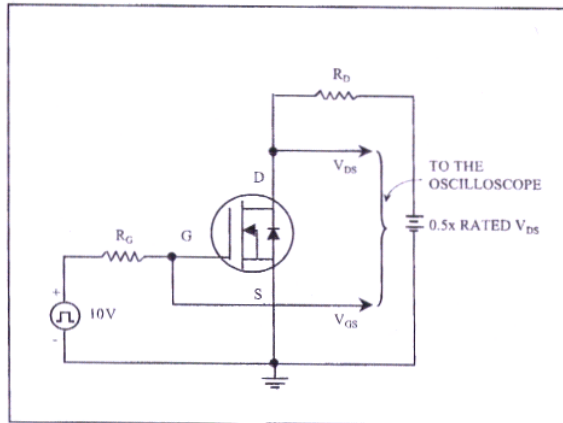

Fig 13. Switching Time Circuit

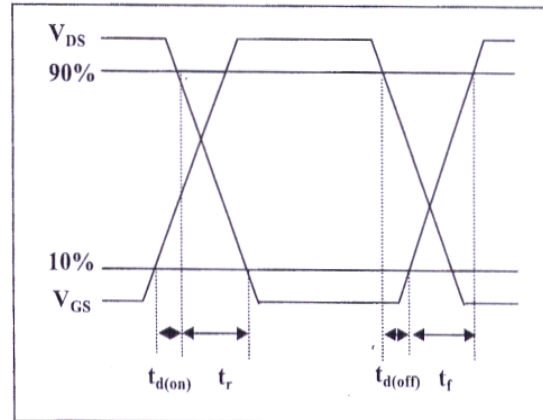

Fig 14. Switching Time Waveform

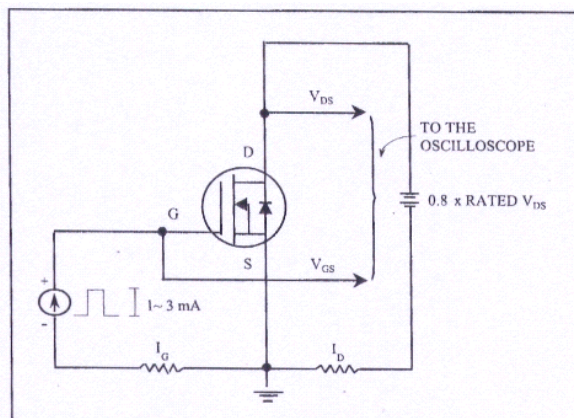

Fig 15. Gate Charge Circuit

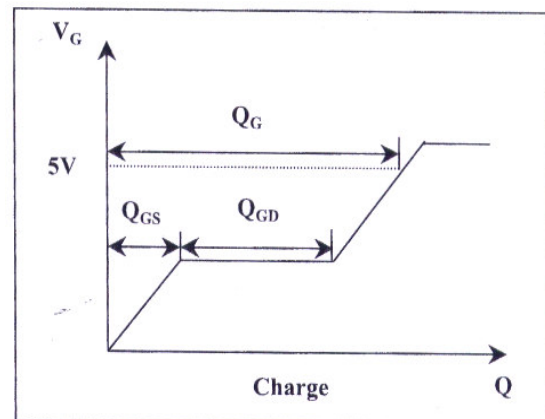

Fig 16. Gate Charge Waveform