

I/O Type Phone 8-bit MCU with DTMF Receiver & CPT Detector

Features**MCU Features**

- MCU operating voltage without CPT Detector $f_{SYS}=3.58\text{MHz}@2.2\text{V}\sim 5.5\text{V}$
- Program Memory: $4\text{K}\times 16 \sim 8\text{K}\times 16$
- RAM Data Memory: $1152\times 8 \sim 2112\times 8$
- 26 bidirectional I/Os with pull-high options
- 2 NMOS output-only lines
- 4 external interrupt input pins
- Dual 16-bit timers with interrupts
- Timer external input
- 8-level stack
- 32768Hz system oscillator
- 32768Hz to 3.58MHz frequency-up circuit
- Real time clock function
- Watchdog timer function
- PFD driver output
- DTMF generator
- DTMF receiver
- Power-down and wake-up feature for power-saving operation

- Multiple Operating Modes: Idle mode, Sleep mode, Green mode and normal mode
- Up to $1.117\mu\text{s}$ instruction cycle with 3.58MHz system clock at $V_{DD}=2.2\text{V}\sim 5.5\text{V}$
- Bit manipulation instructions
- Table read function
- 63 powerful instructions
- All instructions executed in 1 or 2 machine cycles
- Low voltage reset function
- Supported by comprehensive suite of hardware and software tools
- 64-pin LQFP package

CPT Detector Features

- Operating voltage: 2.5V~5.5V
- Low power consumption
- CPT Band: 305~640Hz detection
- Good performance:
 - -8 ~ -39 dBm at $V_{DD}=2.5\text{V}$
 - 0 ~ -27 dBm at $V_{DD}=5\text{V}$

General Description

These phone MCUs are a series of 8-bit high performance, RISC architecture microcontroller devices specially designed for telephone applications. Device flexibility is enhanced with their internal special features such as power-down and wake-up functions, DTMF generator, DTMF receiver, CPT detector, PFD driver, etc. These features combine to ensure applications require a minimum of external components and therefore reduce overall product costs.

Having the advantages of low-power consumption, high-performance, I/O flexibility as well as low-cost, these devices have the versatility to suit a wide range of application possibilities such as DTMF mode Caller ID phone, Home Security products, deluxe feature phones, cordless phones, fax and answering machines, etc.

The call progress tone detector is for Auto-dialing system use. Switched capacitor technology is implemented into the devices to obtain good band pass filter performance characteristics for 305Hz to 640Hz call progress tones which are dual tone multi-frequency signals. When a CPT signal is detected it generates relative envelopes for the microcontroller to determine whether to finish different kinds of CPT signal detections such as dial tones, busy tones, ring-back tones and reorder tones.

These devices will be ideally suited for phone products that comply with versatile dialer specification requirements for different areas or countries. These devices are fully supported by the Holtek range of fully functional development and programming tools, providing a means for fast and efficient product development cycles.

Selection Guide

The following table summarises the main features of each device.

Part No.	VDD	Program Memory	Data Memory	General I/O	Timer	CPT Detector	DTMF Generator	DTMF Receiver	Stack	Package
HT95R43	2.2V~5.5V	4K×16	1152×8	28	16-bit×2	√	√	√	8	64LQFP
HT95R44	2.2V~5.5V	8K×16	2112×8	28	16-bit×2	√	√	√	8	64LQFP

Block Diagram

The following block diagram illustrates the dual-chip structure of the devices, where an individual MCU and CPT Detector devices are combined into a single package.

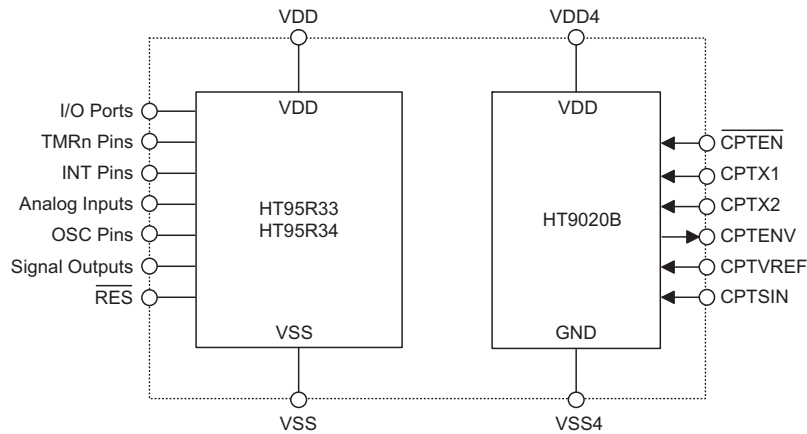

Internal Chip Interconnection Diagram

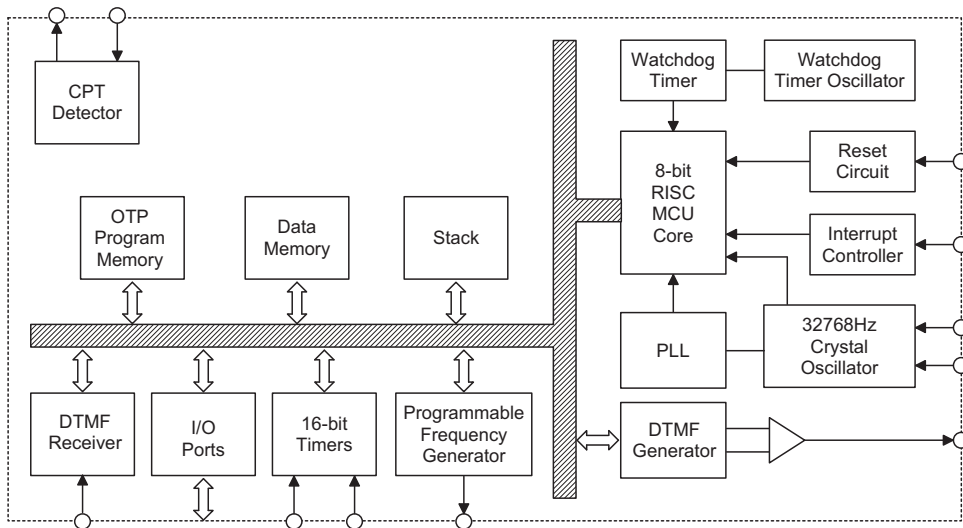

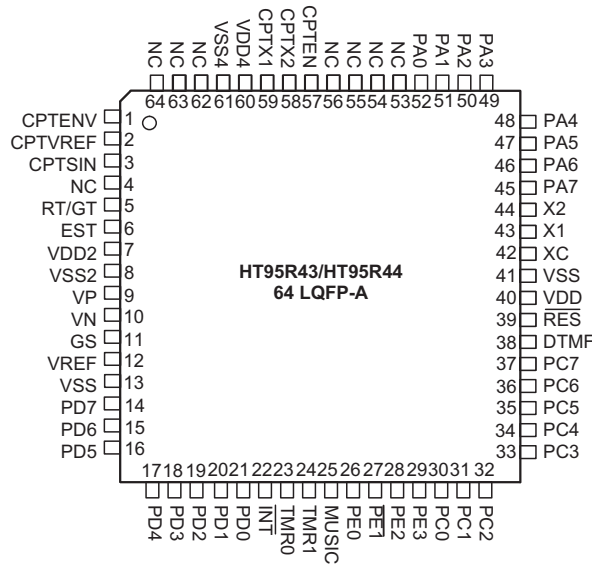
Pin Assignment

Pin Description

Pad Name	I/O	Options	Description
PA0~PA7	I/O	Pull-high Wake-up	Bidirectional 8-bit input/output port. Each individual pin on this port can be configured as a wake-up input by a configuration option. Software instructions determine if the pin is a CMOS output or Schmitt Trigger input. Configuration options determine which pins on the port have pull-high resistors.
PC0, PC5, PC7	I/O	Pull-high	Bidirectional input/output port. Software instructions determine if the pin is a CMOS output or Schmitt Trigger input. Configuration options determine which pins on the port have pull-high resistors. When the multi-function interrupt is enabled an interrupt will be generated whenever PC0 or PC5 has a falling edge, or PC7 has a rising edge. When in the idle mode such an interrupt will wake up the device.
PC1, PC4, PC6	I/O	Pull-high	Bidirectional input/output port. Software instructions determine if the pin is a CMOS output or Schmitt Trigger input. Configuration options determine which pins on the port have pull-high resistors.
PC2, PC3	O	—	NMOS output structures
PD0~PD7	I/O	Pull-high	Bidirectional 8-bit input/output port. Software instructions determine if the pin is a CMOS output or Schmitt Trigger input. Configuration options determine which nibble on the port have pull-high resistors.
PE0~PE3	I/O	Pull-high	Bidirectional 4-bit input/output port. Software instructions determine if the pin is a CMOS output or Schmitt Trigger input. Configuration options determine if all the pins on the port have pull-high resistors.
$\overline{\text{INT}}$	I	—	External interrupt Schmitt trigger input. Edge trigger activated on high to low transition. No pull-high resistor.
TMR0	I	—	Timer/Event Counter 0 Schmitt trigger input . No pull-high resistor.
TMR1	I	—	Timer/Event Counter 1 Schmitt trigger input . No pull-high resistor.
DTMF	O	—	Dual Tone Multi Frequency Output
MUSIC	O	—	CMOS output structure Programmable Frequency Divider pin.

Pad Name	I/O	Options	Description
RT/GT	I/O	—	Tone acquisition time and release time can be set through connection with external resistor and capacitor CMOS IN/OUT
EST	O	—	Early steering output CMOS out
VP	I	—	Operational amplifier non-inverting input
VN	I	—	Operational amplifier inverting input
GS	O	—	Operational amplifier output terminal
VREF	O	—	Reference voltage output, normally $V_{DD}/2$
X1 X2	I O	—	X1 and X2 are connected to an external 32768Hz crystal or resonator for the system clock.
XC	—	—	External low pass filter pin used for the frequency up conversion circuit.
RES	I	—	Schmitt trigger reset input. Active low.
VDD	—	—	Positive power supply
VSS	—	—	Negative power supply, ground.
VDD2	—	—	DTMF receiver positive power supply
VSS2	—	—	DTMF receiver negative power supply

Note: Each pin on PA can be programmed through a configuration option to have a wake-up function.

Functional Description

As these devices contain multiple internal chips, for a detailed functional description, users must refer to the relevant individual datasheets for both the MCU and the CPT Detector. The following table shows which individual devices are inside each package.

Device	MCU	CPT Detector
HT95R43	HT95R33	HT9020B
HT95R44	HT95R34	HT9020B

Multi-chip Internal Devices

Although most of the functional description material will be located in the individual datasheets, there are some special considerations which need to be taken into account when using multi-chip devices. These points will be mentioned in the hardware and software consideration sections.

Multi-chip Hardware Considerations

As these single-package multi-chip devices are composed of an individual MCU and CPT Detector chips, using them together requires the user to take care of some special points.

- **Absolute Maximum Ratings**
The Absolute Maximum Ratings for the two individual chips must be checked for discrepancies and the necessary care taken in device handling and usage.
- **Power Supply**
Examination of the block diagram will reveal that the CPT Detector ground and power supply pin, VSS4 and VDD4, are not internally connected to the MCU ground and power supply pins, VSS and VDD. For this reason these two pins must be connected externally.

When calculating the total current consumption of the device, the internal DC specifications of the two internal chips must be consulted and the individual currents added together.

When calculating the total current consumption of the device, the internal DC specifications of the two internal chips must be consulted and the individual currents added together.

- **Power Down and Wake up**
Please note that if the MCU is powered down or placed into a low power mode to conserve power, that the CPT Detector will continue running and will consume a certain amount of power. The CPT Detector can of course be powered down by pulling its CPTEN pin high.
- **Functional Pins**
Examination of the block diagram will reveal that the CPT Detector pins, CPTEN, CPTX1, CPTX2, CPTENV, CPTVREF, CPTSIN, VDD4, VSS4, have no internal connection to the MCU pins. For this reason these pins must be controlled and connected externally.

Multi-chip Programming Considerations

As there are no internal signal connections between the two internal chips there are no real programming considerations for these devices. It is only necessary to realise that if the MCU is switched into any of its low power modes or executes the HALT instruction by the application program to reduce power consumption, that the CPT Detector will continue operating and therefore contribute to the overall power consumption. The CPT Detector can only be powered-down manually using its CPTEN pin.

Application Circuits

DTMF Receiver Single-ended Input Application Circuit

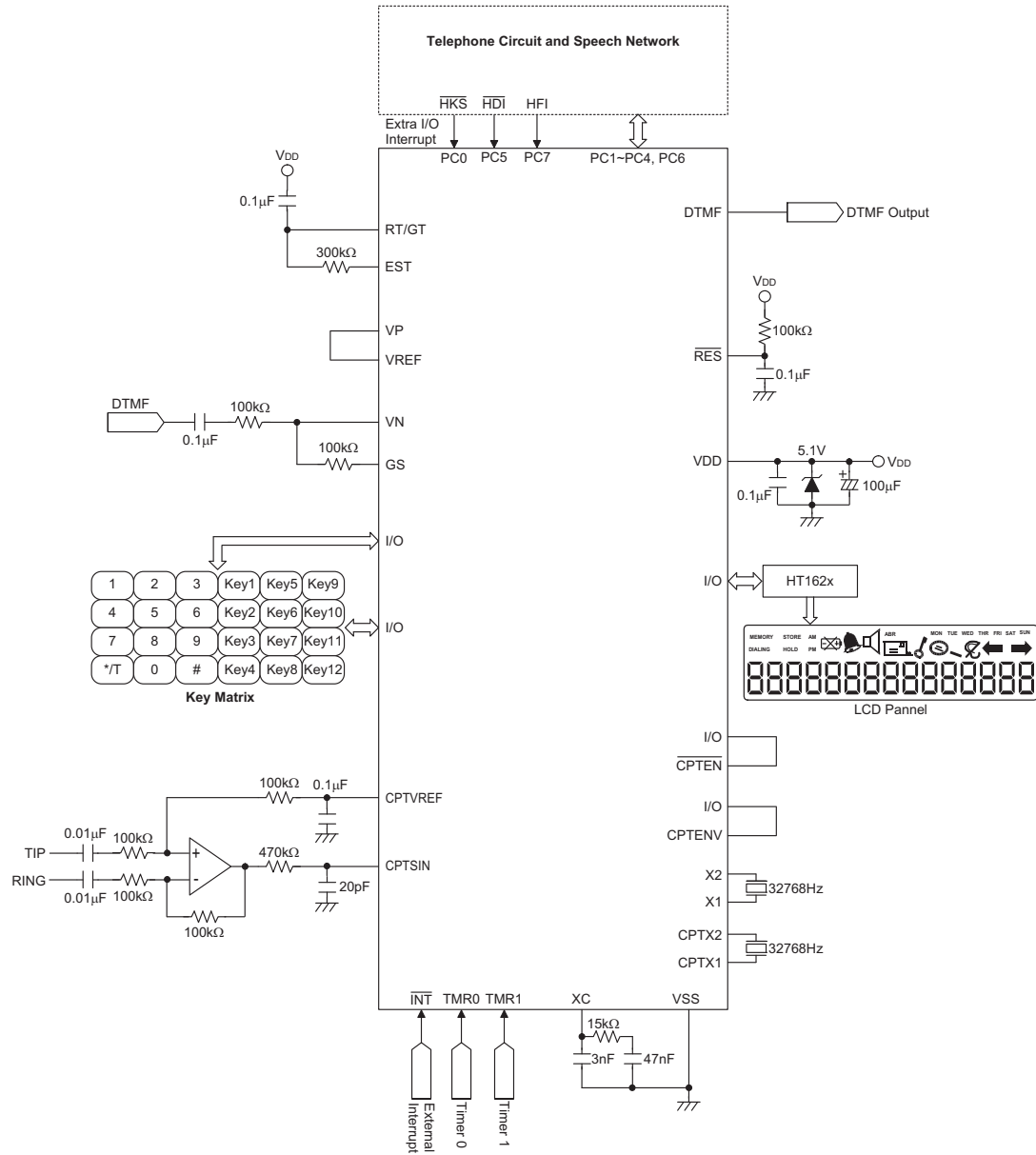

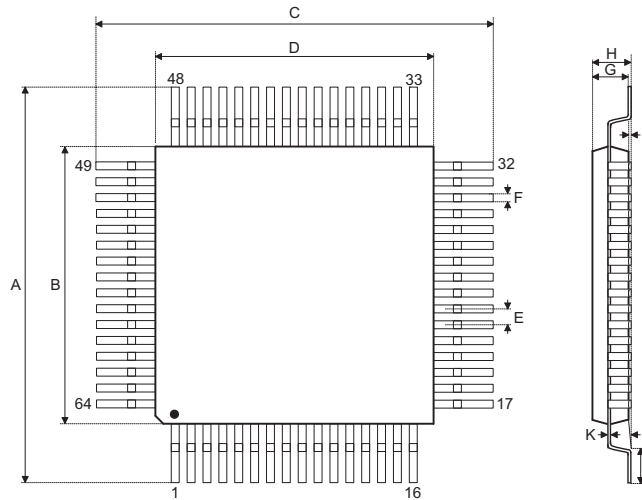
Package Information
64-pin LQFP (7mm×7mm) Outline Dimensions

Symbol	Dimensions in inch		
	Min.	Nom.	Max.
A	0.350	—	0.358
B	0.272	—	0.280
C	0.350	—	0.358
D	0.272	—	0.280
E	—	0.016	—
F	0.005	—	0.009
G	0.053	—	0.057
H	—	—	0.063
I	0.002	—	0.006
J	0.018	—	0.030
K	0.004	—	0.008
α	0°	—	7°

Symbol	Dimensions in mm		
	Min.	Nom.	Max.
A	8.90	—	9.10
B	6.90	—	7.10
C	8.90	—	9.10
D	6.90	—	7.10
E	—	0.40	—
F	0.13	—	0.23
G	1.35	—	1.45
H	—	—	1.60
I	0.05	—	0.15
J	0.45	—	0.75
K	0.09	—	0.20
α	0°	—	7°

Holtek Semiconductor Inc. (Headquarters)

No.3, Creation Rd. II, Science Park, Hsinchu, Taiwan
Tel: 886-3-563-1999
Fax: 886-3-563-1189
<http://www.holtek.com.tw>

Holtek Semiconductor Inc. (Taipei Sales Office)

4F-2, No. 3-2, YuanQu St., Nankang Software Park, Taipei 115, Taiwan
Tel: 886-2-2655-7070
Fax: 886-2-2655-7373
Fax: 886-2-2655-7383 (International sales hotline)

Holtek Semiconductor Inc. (Shenzhen Sales Office)

5F, Unit A, Productivity Building, No.5 Gaoxin M 2nd Road, Nanshan District, Shenzhen, China 518057
Tel: 86-755-8616-9908, 86-755-8616-9308
Fax: 86-755-8616-9722

Holtek Semiconductor (USA), Inc. (North America Sales Office)

46729 Fremont Blvd., Fremont, CA 94538, USA
Tel: 1-510-252-9880
Fax: 1-510-252-9885
<http://www.holtek.com>

Copyright © 2010 by HOLTEK SEMICONDUCTOR INC.

The information appearing in this Data Sheet is believed to be accurate at the time of publication. However, Holtek assumes no responsibility arising from the use of the specifications described. The applications mentioned herein are used solely for the purpose of illustration and Holtek makes no warranty or representation that such applications will be suitable without further modification, nor recommends the use of its products for application that may present a risk to human life due to malfunction or otherwise. Holtek's products are not authorized for use as critical components in life support devices or systems. Holtek reserves the right to alter its products without prior notification. For the most up-to-date information, please visit our web site at <http://www.holtek.com.tw>.