

# LINEAR INTEGRATED CIRCUITS

T-77-01

**Dual Attenuator,  $G_v = 17dB$ ,  $V_{CC} = 16V$  Max** 14-Lead DIP, See Diag. 247

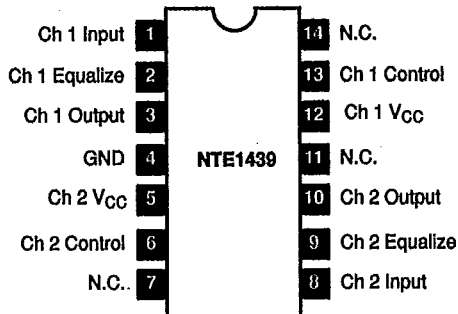

**Video IF Amp, Detector, AGC,  $V_{CC} = 12V$  Typ** 28-Lead DIP, See Diag. 253

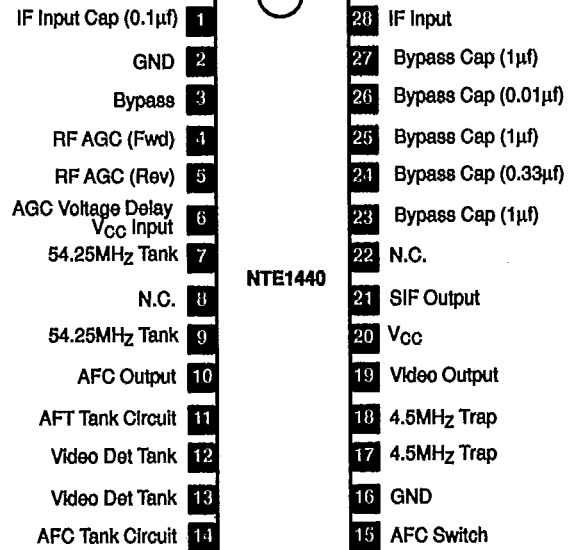

**FM IF System,  $V_{CC} = 12V$**  16-Lead DIP, See Diag. 248

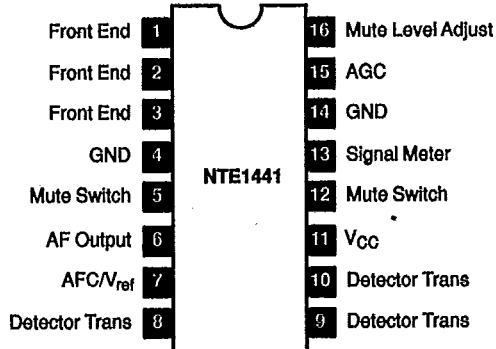

**Balance Modulator,  $V_{CC} = 12V$**  14-Lead DIP, See Diag. 247

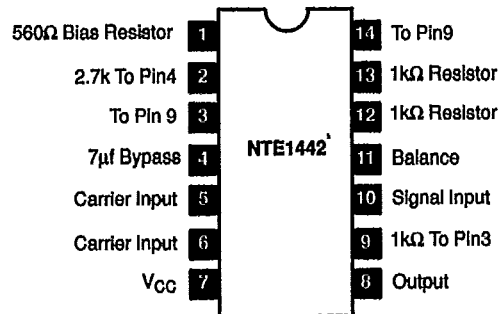

**Sound IF Amp,  $V_{CC} = 12V$**  14-Lead DIP, See Diag. 247

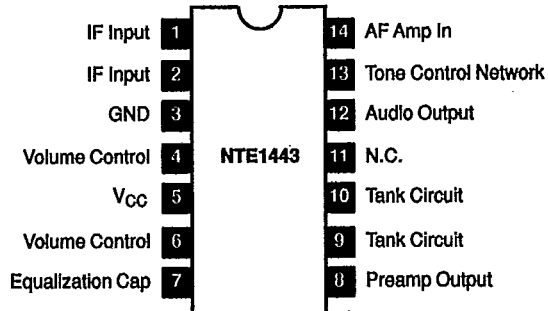

**Servo Control for VCR,  $V_{CC} = 15.6V$**  16-Lead DIP See Diag. 249

