



U7SH32

CMOS IC

2-INPUT OR GATE

DESCRIPTION

The U7SH32 is a 2-input OR gate, it provides the Function $Y=A+B$.

FEATURES

- * Operation Voltage Range: 2~5.5V
- * Low Power Dissipation: $I_{CC}=2\mu A(\text{Max})$
- * High Speed: $t_{PD}=3.8\text{ns}(\text{Typ})$
- * High Noise Immunity

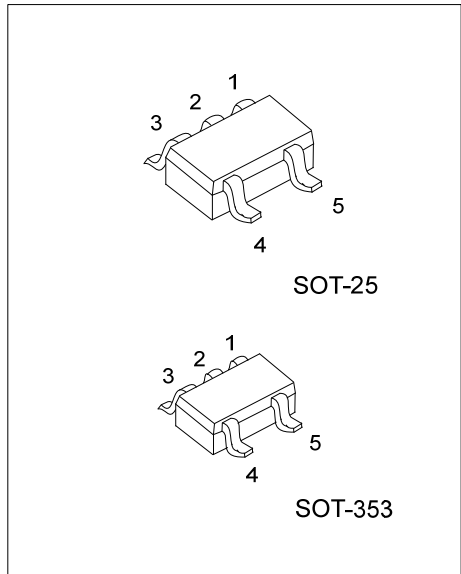

ORDERING INFORMATION

Order Number		Package	Packing
Lead Free	Halogen Free		
U7SH32L-AF5-R	U7SH32G-AF5-R	SOT-25	Tape Reel
U7SH32L-AL5-R	U7SH32G-AL5-R	SOT-353	Tape Reel

<p>U7SH32L-AF5-R</p> <p>(1)Packing Type (2)Package Type (3)Lead Free</p>	<p>(1) R: Tape Reel (2) AF5: SOT-25, AL5: SOT-353 (3) G: Halogen Free, L: Lead Free</p>
--	---

MARKING

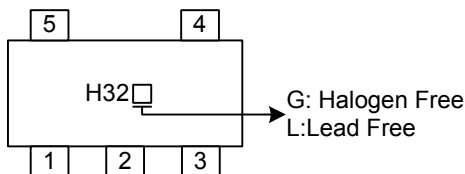

■ PIN CONFIGURATION

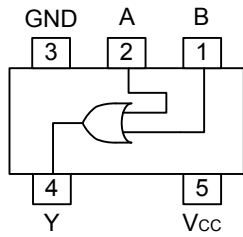

■ FUNCTION TABLE (each gate)

INPUT		OUTPUT
A	B	Y
L	L	L
L	H	H
H	L	H
H	H	H

■ LOGIC DIAGRAM (positive logic)

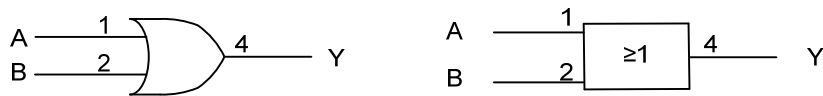

■ ABSOLUTE MAXIMUM RATING (unless otherwise specified)(Note 1)

PARAMETER	SYMBOL	RATINGS	UNIT
Supply Voltage	V_{CC}	-0.5~7	V
Input Voltage	V_{IN}	-0.5~7	V
Output Voltage	V_{OUT}	-0.5~ $V_{CC}+0.5$	V
Input Clamp Current	I_{IK}	-20	mA
Output Clamp Current	I_{OK}	±20	mA
Output Current	I_{OUT}	±25	mA
V_{CC} or GND Current	I_{CC}	±50	mA
Power Dissipation	P_D	200	mW
Storage Temperature	T_{STG}	-65 ~ +150	°C

Note 1. The input and output voltage ratings may be exceeded if the input and output current ratings are observed.

2. Absolute maximum ratings are those values beyond which the device could be permanently damaged.

Absolute maximum ratings are stress ratings only and functional device operation is not implied.

■ RECOMMENDED OPERATING CONDITIONS

PARAMETER	SYMBOL	CONDITIONS	MIN	TYP	MAX	UNIT
Supply Voltage	V_{CC}		2		5.5	V
Input Voltage	V_{IN}		0		5.5	V
Output Voltage	V_{OUT}		0		V_{CC}	V
Input Transition Rise or Fall Rate	dt/dv	$V_{CC}=3.3+0.3V$			100	ns/V
		$V_{CC}=5.0+0.5V$			20	
Operating Temperature	T_A		-40		85	°C

■ STATIC CHARACTERISTICS

PARAMETER	SYMBOL	TEST CONDITIONS	$T_A=25^{\circ}C$			$-40\sim 85^{\circ}C$		UNIT
			MIN	TYP	MAX	MIN	MAX	
High-Level Input Voltage	V_{IH}	$V_{CC}=2.0V$	1.5			1.5		V
		$V_{CC}=3.0V$	2.1			2.1		
		$V_{CC}=5.5V$	3.85			3.85		
Low-Level Input Voltage	V_{IL}	$V_{CC}=2.0V$			0.5		0.5	V
		$V_{CC}=3.0V$			0.9		0.9	
		$V_{CC}=5.5V$			1.65		1.65	
High-Level Output Voltage	V_{OH}	$V_{CC}=2.0V, I_{OH}=-50\mu A$	1.9	2.0		1.9		V
		$V_{CC}=3.0V, I_{OH}=-50\mu A$	2.9	3.0		2.9		
		$V_{CC}=4.5V, I_{OH}=-50\mu A$	4.4	4.5		4.4		
		$V_{CC}=3.0V, I_{OH}=-4mA$	2.58			2.48		
		$V_{CC}=4.5V, I_{OH}=-8mA$	3.94			3.8		
Low-Level Output Voltage	V_{OL}	$V_{CC}=2.0V, I_{OL}=50\mu A$			0.1		0.1	V
		$V_{CC}=3.0V, I_{OL}=50\mu A$			0.1		0.1	
		$V_{CC}=4.5V, I_{OL}=50\mu A$			0.1		0.1	
		$V_{CC}=3.0V, I_{OL}=4mA$			0.36		0.44	
		$V_{CC}=4.5V, I_{OL}=8mA$			0.36		0.44	
Input Leakage Current	$I_{I(LEAK)}$	$V_{CC}=0\sim 5.5V, V_{IN}=V_{CC}$ or GND			±0.1		±1	μA
Quiescent Supply Current	I_{CC}	$V_{CC}=5.5V, V_{IN}=V_{CC}$ or GND, $I_{OUT}=0$			2		20	μA
Input Capacitance	C_{IN}	$V_{CC}=5V, V_{IN}=V_{CC}$ or GND		4	10		10	pF

■ DYNAMIC CHARACTERISTICS (Input: $t_R, t_F=3ns$)

PARAMETER	SYMBOL	TEST CONDITIONS	T _A =25°C			-40~85°C		UNIT
			MIN	TYP	MAX	MIN	MAX	
Propagation Delay From Input (A or B) to Output(Y)	t _{PLH}	V _{CC} =3.3±0.3, C _L =15pF		5.5	7.9	1.0	9.5	ns
	t _{PHL}			5.5	7.9	1.0	9.5	
	t _{PLH}	V _{CC} =3.3±0.3, C _L =50pF		8.0	11.4	1.0	13.0	
	t _{PHL}			8.0	11.4	1.0	13.0	
Propagation Delay From Input (A or B) to Output(Y)	t _{PLH}	V _{CC} =5±0.5, C _L =15pF		3.8	5.5	1.0	6.5	ns
	t _{PHL}			3.8	5.5	1.0	6.5	
	t _{PLH}	V _{CC} =5±0.5, C _L =50pF		5.3	10	1.0	8.5	
	t _{PHL}			5.3	10	1.0	8.5	
Power Dissipation Capacitance	C _{PD}	No load		15				pF

UTC assumes no responsibility for equipment failures that result from using products at values that exceed, even momentarily, rated values (such as maximum ratings, operating condition ranges, or other parameters) listed in products specifications of any and all UTC products described or contained herein. UTC products are not designed for use in life support appliances, devices or systems where malfunction of these products can be reasonably expected to result in personal injury. Reproduction in whole or in part is prohibited without the prior written consent of the copyright owner. The information presented in this document does not form part of any quotation or contract, is believed to be accurate and reliable and may be changed without notice.