

isc Silicon NPN Power Transistor

BU931RPF1

DESCRIPTION

- High Voltage
- DARLINGTON

APPLICATIONS

- High ruggedness electronic ignitions
- High voltage ignition coil driver

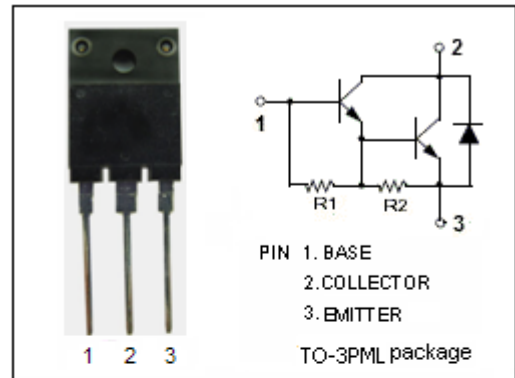

ABSOLUTE MAXIMUM RATINGS (T_a=25°C)

SYMBOL	PARAMETER	VALUE	UNIT
V _{CBO}	Collector-Base Voltage	450	V
V _{CEO}	Collector-Emitter Voltage	400	V
V _{EBO}	Emitter-Base Voltage	5	V
I _C	Collector Current	15	A
I _{CM}	Collector Current-peak	30	A
I _B	Base Current	1	A
I _{BM}	Base Current-peak	5	A
P _C	Collector Power Dissipation @T _C =25°C	60	W
T _j	Junction Temperature	150	°C
T _{stg}	Storage Temperature Range	-40~150	°C

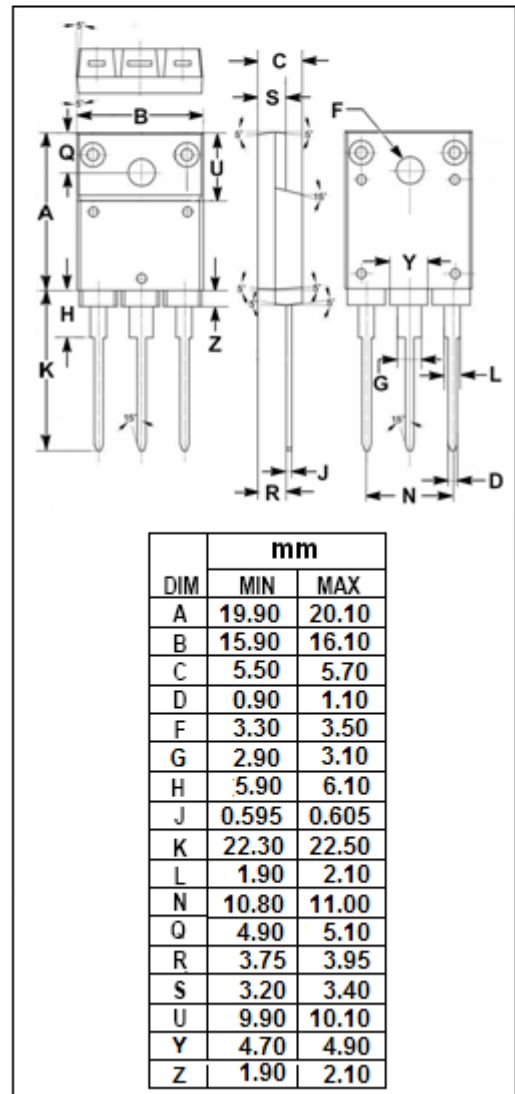

THERMAL CHARACTERISTICS

SYMBOL	PARAMETER	MAX	UNIT
R _{th j-c}	Thermal Resistance, Junction to Case	2.08	°C/W

isc Silicon NPN Power Transistor

BU931RPF1

ELECTRICAL CHARACTERISTICS

T_C=25°C unless otherwise specified

SYMBOL	PARAMETER	CONDITIONS	MIN	TYP.	MAX	UNIT
V _{CEO(SUS)}	Collector-Emitter Sustaining Voltage	I _C = 0.1A; I _B = 0; L= 10mH	400			V
V _{CE(sat)-1}	Collector-Emitter Saturation Voltage	I _C = 7A; I _B = 70mA			1.6	V
V _{CE(sat)-2}	Collector-Emitter Saturation Voltage	I _C = 8 A; I _B = 100mA			1.8	V
V _{CE(sat)-3}	Collector-Emitter Saturation Voltage	I _C = 10 A; I _B = 250mA			1.8	V
V _{BE(sat)-1}	Base-Emitter Saturation Voltage	I _C = 8 A; I _B = 100mA			2.2	V
V _{BE(sat)-2}	Base-Emitter Saturation Voltage	I _C = 10A; I _B = 250mA			2.2	V
I _{CES}	Collector Cutoff Current	V _{CE} = 450V; V _{BE} = 0 V _{CE} = 450V; V _{BE} = 0; T _j = 125°C			1.0 5.0	mA
I _{CEO}	Collector Cutoff Current	V _{CE} = 400V; I _B = 0			1.0	mA
I _{EBO}	Emitter Cutoff Current	V _{EB} = 5V; I _C = 0			50	mA
h _{FE}	DC Current Gain	I _C = 5A; V _{CE} = 10V	300			
V _{ECF}	C-E Diode Forward Voltage	I _F = 10A			2.8	V