

### Packages



3 pin SIP (suffix UA)

### Features and Benefits

1. Operation down to 2.5V
2. Wide operating voltage range
3. High sensitivity for direct reed switch replacement applications
4. Omnipolar, output switches with absolute value of North or South pole from magnet
6. Temperature compensation
7. Open-Collector pre-driver
8. 60V maximum withstand voltage
9. Reverse polarity protection
10. Package: TO-92S(SIP)

### Functional Block Diagram

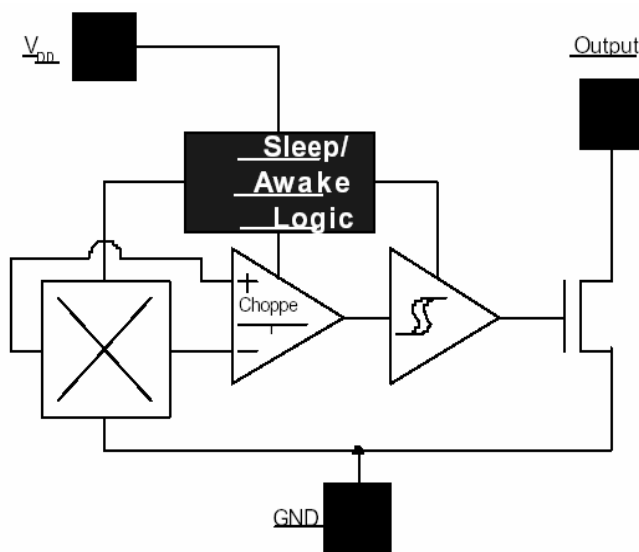

### Application Examples

1. Brush-less DC Motor
2. Brush-less DC Fan
3. Revolution counting
4. Speed measurement

### General Description:

The SS40A Omnipolar Hall effect sensor IC is fabricated from mixed signal CMOS technology. It incorporates advanced chopper-stabilization techniques to provide accurate and stable magnetic switch points.

The circuit design provides an internally controlled clocking mechanism to cycle power to the Hall element and analog signal processing circuits. This serves to place the high current-consuming portions of the circuit into a “Sleep” mode. Periodically the device is “Awakened” by this internal logic and the magnetic flux from the Hall element is evaluated against the predefined thresholds. If the flux density is above or below the  $B_{OP}/B_{RP}$  thresholds then the output transistor is driven to change states accordingly. While in the “Sleep” cycle the output transistor is latched in its previous state. The design has been optimized for service in applications requiring extended operating lifetime in battery powered systems. An internal bandgap regulator is used to provide temperature compensated supply voltage for internal circuits and allows a wide operating supply range.

The output transistor of the SS40A will be latched on ( $B_{OP}$ ) in the presence of a sufficiently strong South or North magnetic field facing the marked side of the package. The output will be latched off ( $B_{RP}$ ) in the absence of a magnetic field.

### Typical Application Circuit

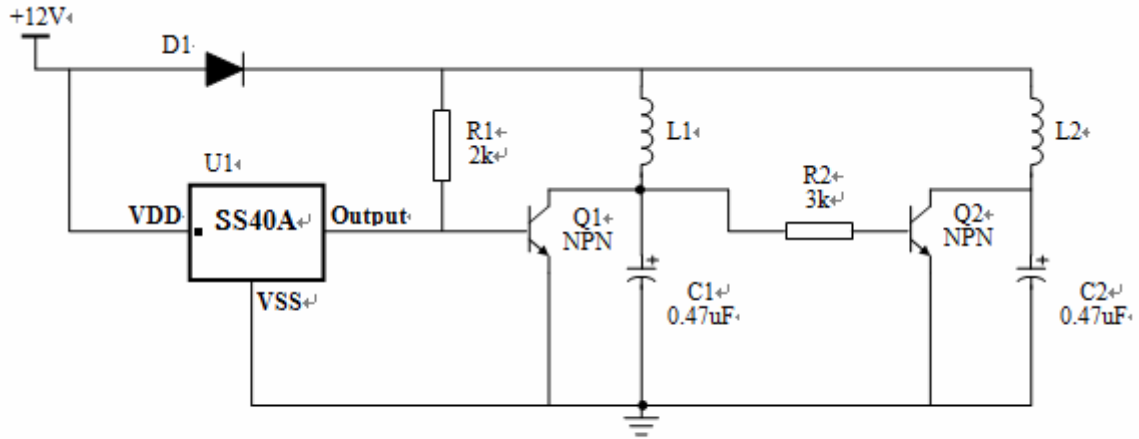

### Brush-less DC Fan

SEC's pole-independent sensing technique allows for operation with either a north pole or south pole magnet orientation, enhancing the manufacturability of the device. The state-of-the-art technology provides the same output polarity for either pole face.

It is strongly recommended that an external bypass be connected (in close proximity to the Hall sensor) between the supply and ground of the device to reduce both external noise and noise generated by the chopper-stabilization technique. This is especially true due to the relatively high impedance of battery supplies.

### Functional Block Diagrams

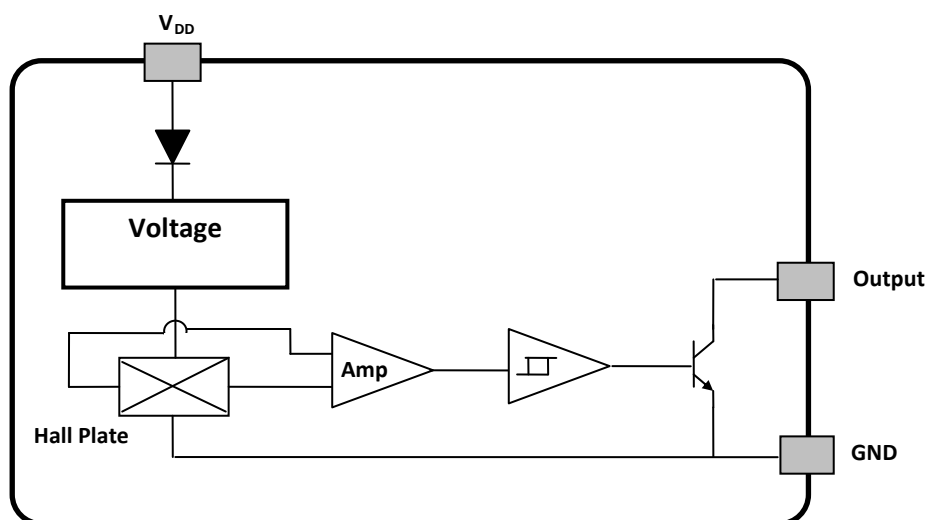

### Pin Definitions and Descriptions

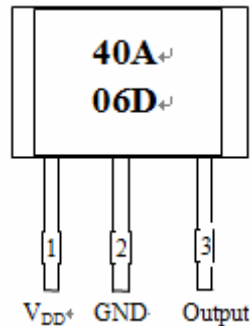

SIP Pin №	Name	Type	Function
1	VDD	Supply	Supply Voltage pin
3	OUT	Output	Open Drain Output pin
2	GND	Ground	Ground pin

Table 1: Pin definitions and descriptions

### Absolute Maximum Ratings

Parameter	Symbol	Value	Units
Supply Voltage (operating)	$V_{DD}$	24	V
Reverse Voltage,	$-V_{DD}$	-24	V
Output Voltage	$V_{OUT}$	30	V
Output Current	$I_{OUT}$	50	mA
Operating Temperature Range	$T_A$	-20 to 85	°C
Storage Temperature Range	$T_S$	-55 to 150	°C
ESD Sensitivity	-	4000	V

Table 2: Absolute maximum ratings

Exceeding the absolute maximum ratings may cause permanent damage. Exposure to absolute-maximum-rated conditions for extended periods may affect device reliability.

### DC Electrical Characteristics

DC Operating Parameters:  $T_A = 25^\circ\text{C}$ ,  $V_{DD} = 2.75\text{V}$ .

Parameter	Symbol	Test Conditions	Min	Typ	Max	Units
Operating Voltage	$V_{DD}$	Operating	4.5	5	24	V
Supply Current	$I_{DD}$	Average		5	10	mA
Saturation Voltage	$V_{SAT}$	$I_{OUT} = 20\text{mA}$ , $B > B_{OP}$		0.4	0.5	V
Output Leakage	$I_{OFF}$	$B < B_{RP}$ , $V_{OUT} = 20\text{V}$		0.01	5	$\mu\text{A}$
Output Rise Time	$t_r$	$R_L = 1.1\text{K } \Omega$ , $C_L = 20\text{pf}$		0.3	1.5	$\mu\text{s}$
Output Fall Time	$t_f$	$R_L = 1.1\text{K } \Omega$ , $C_L = 20\text{pf}$		0.3	1.5	$\mu\text{s}$

Table 3: DC electrical characteristics

### Magnetic Characteristics

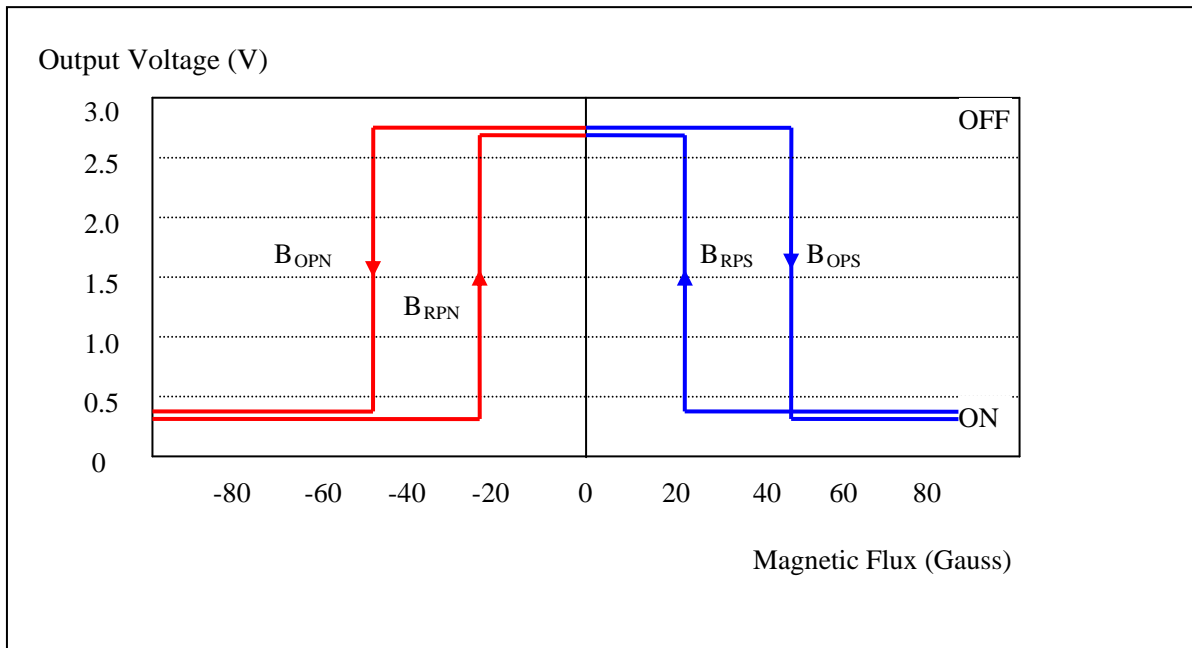

Operating Parameters:  $T_A = 25^\circ\text{C}$ ,  $V_{DD} = 2.75V_{DC}$

SS40A

Parameter	Symbol	Min	Type	Max	Units
Operating Point	$B_{OP}$	-		70	Gs
Release Point	$B_{RP}$	-70		-	Gs
Hysteresis	$B_{HYST}$	60		100	Gs

Table 4: Magnetic Specifications

### ESD Protection

Human Body Model (HBM) tests according to: Mil. Std. 883F method 3015.7

Parameter	Symbol	Limit Values		Unit	Notes
		Min	Max		
ESD Voltage	$V_{ESD}$		$\pm 4$	kV	

### Performance Characteristics

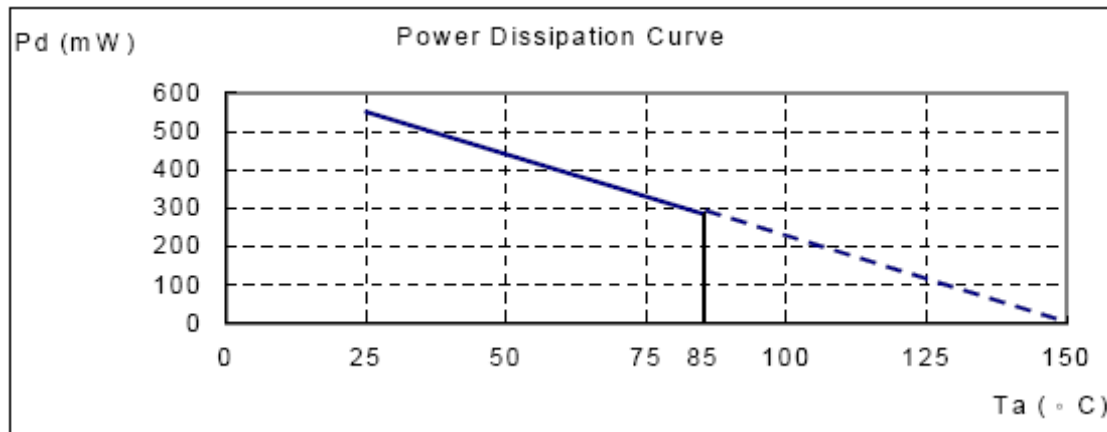

### Unique Features

#### CMOS Hall IC Technology

The chopper stabilized amplifier uses switched capacitor techniques to eliminate the amplifier offset voltage, which, in bipolar devices, is a major source of temperature sensitive drift. CMOS makes this advanced technique possible. The CMOS chip is also much smaller than a bipolar chip, allowing very sophisticated circuitry to be placed in less space. The small chip size also contributes to lower physical stress and less power consumption.

### Installation Comments

Consider temperature coefficients of Hall IC and magnetic, as well as air gap and life time variations. Observe temperature limits during wave soldering. Typical IR solder-reflow profile:

- No Rapid Heating and Cooling.
- Recommended Preheating for max. 2minutes at 150°C
- Recommended Reflowing for max. 5seconds at 240°C

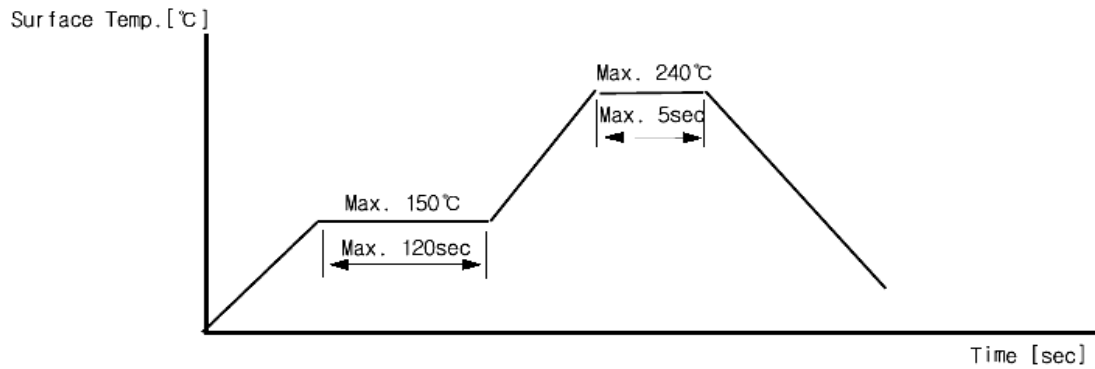

## ESD Precautions

Electronic semiconductor products are sensitive to Electro Static Discharge (ESD).

Always observe Electro Static Discharge control procedures whenever handling semiconductor products.

### Package UA, 3-Pin

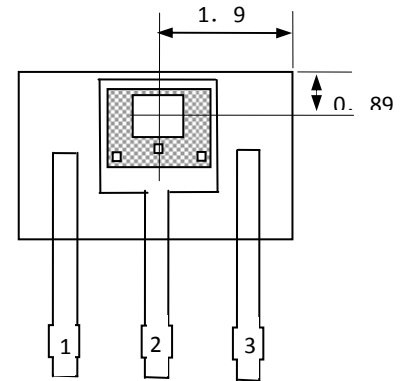
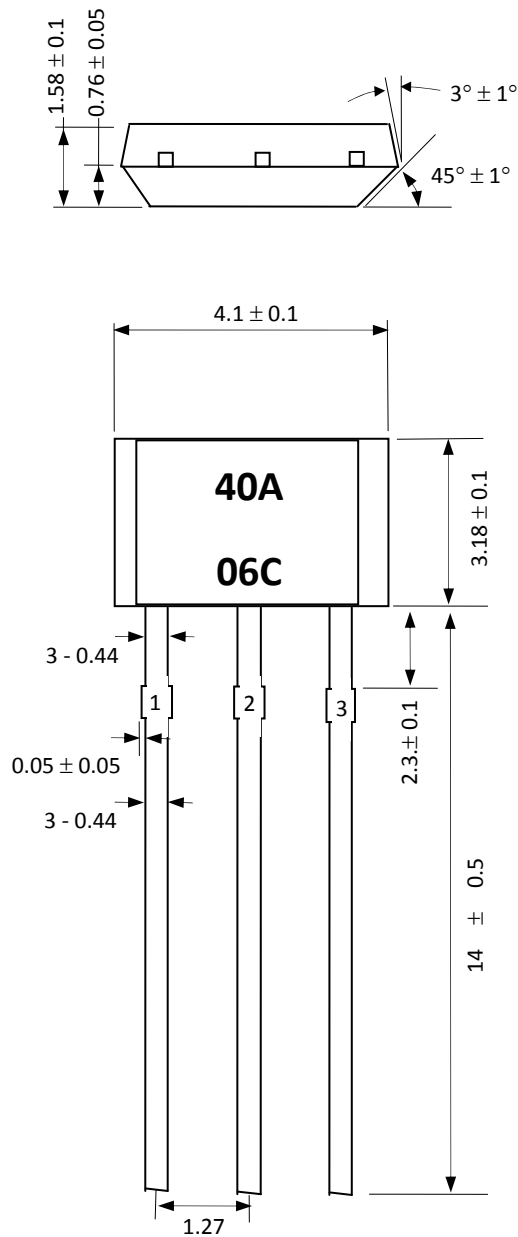

**Sensor Location**

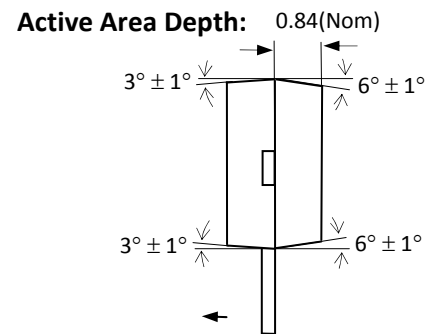

**Notes:**

- 1). Controlling dimension : mm ;
- 2). Leads must be free of flash and plating voids ;
- 3). Do not bend leads within 1 mm of lead to package interface ;

SIP:

### Ordering Information

Part No.	Pb-free	Temperature Code	Package Code	Packing
SS40AEUA	YES	-40°C to 85°C	TO-92	Bulk, 1000 pieces/bag
SS40AKUA	YES	-40°C to 125°C	TO-92	Bulk, 1000 pieces/bag
SS40ALUA	YES	-40°C to 150°C	TO-92	Bulk, 1000 pieces/bag