

FAN REMOTE CONTROL DECODER USED TOGETHER WITH SC5104

DESCRIPTION

SC8207 is a high performance electronic fan controller LSI, Speed control, off-timer, nature wind, sleep mode are all built into a single chip. Light control, buzzer output, key control input, as well as remote control decoding circuitry are all provided to build a full function electronic fan with remote control capability having the highest performance with the least external components. Pin assignment and application circuit are optimized for easy PCB layout and cost saving for electronic fan application.

SC8207 adopted SDIP-22 or DIP-20 package.

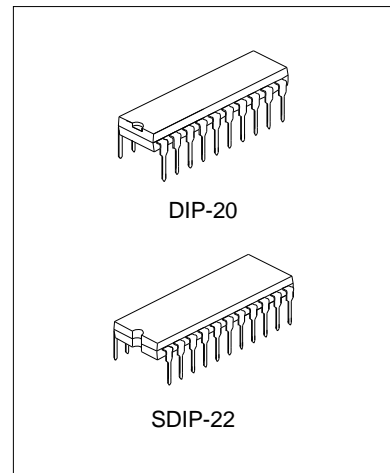

FEATURES

- * Two groups swing function: level swing , cold-wind switch level swing , vertical swing
- * Independent light controlling: extension “ L”
- * Three operation modes: ordinary, nature and rhythm sleep.
- * Three speed modes: strong, middle and low
- * Memory start-up mode
- * Middle wind start-up
- * Buzzer indicator function operation
- * Two bits consumer code
- * Built-in 455kHz oscillator circuit
- * Continued press key for 6 sec, send out “Bi-Bi”
- * Cooperate with SC5104 coder can build a full function electronic
- * "ON/OFF" key select: "ON/OFF" ——“K” version
"ON/SPEED" —— other version
- * Timer mode: A4: 0.5, 1, 2, 4 hours accumulated timer
N3: 1, 2, 4 hours non-accumulated

APPLICATIONS

- * Fan remote controller
- * Air cleaner
- * Humidifier
- * Heater

ORDERING INFORMATION

Part	Package	Accumulated	Non-accumulated	Light control	Cold-wind switch	Vertical swing
SC8207N3	DIP-20	--	√	--	--	√
SC8207N3L	SDIP-22	--	√	√	--	√
SC8207A4K	DIP-20	√	--	--	--	√
SC8207A4KL	SDIP-22	√	--	√	--	√
SC8207A4KS	DIP-20	√	--	--	√	--
SC8207A4KSL	SDIP-22	√	--	√	√	--

Note: “A4” indicated have four time output (0.5, 1, 2, 4 hour) accumulated timer mode.

“N3” indicated have three time output (1, 2, 4 hour) non-accumulated timer mode.

“L” indicated have light output mode.

BLOCK DIAGRAM

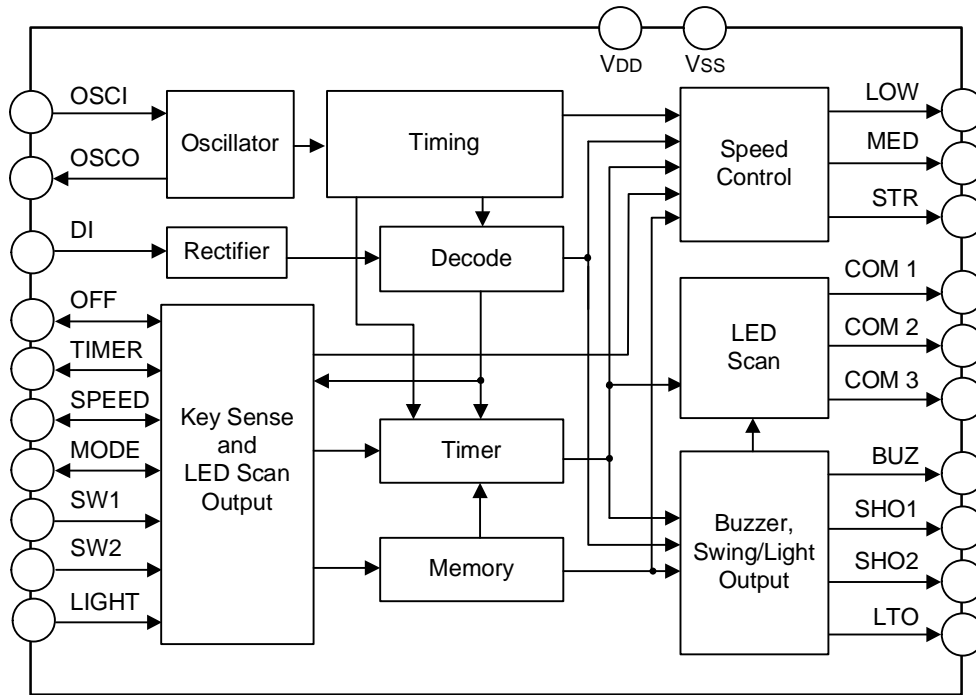

ABSOLUTE MAXIMUM RATING (T_{amb}=25°C)

Characteristics	Symbol	Ratings	Unit
Supply Voltage	V _{DD}	-0.3~6	V
Input/Output Voltage	V _{IN}	V _{SS} -0.3V ~ V _{DD} +0.3V	V
Power Consumption	P _D	500	mW
Operating Temperature	T _{opr}	-10 ~ +70	°C
Storage Temperature	T _{stg}	-40~+125	°C

DC ELECTRICAL CHARACTERISTICS (unless otherwise specified, T_{amb}=25°C, V_{DD}=5.0V)

Characteristics	Symbol	Test conditions	Min.	Typ.	Max.	Unit
Supply Voltage	V _{DD}	--	3.0	5.0	6.0	V
Static Consumption Current	I _{SB}	V _{DD} -V _{SS} =5V, OSC stop, no load	--	--	500	μA
Input High Level Voltage	V _{IH}	--	0.7V _{DD}		V _{DD}	V
Input Low Level Voltage	V _{IL}	--	0	--	0.3V _{DD}	V
OFF, MODE, SPEED, TIMER Scan Output Current	I _{OH}	V _{DD} =5.0V	--	10	--	mA
COM1~COM3 Scan Output Sink Current	I _{OL}	V _{DD} =5.0V, V _o =0.7V	--	40	--	mA
Driver Output Current	I _{OL}	V _{DD} =5.0V, V _o =0.7V	--	10	--	mA
Buzzer Output Current	I _{OH}	V _{DD} =5.0V, V _o =4.3V	--	5	--	mA

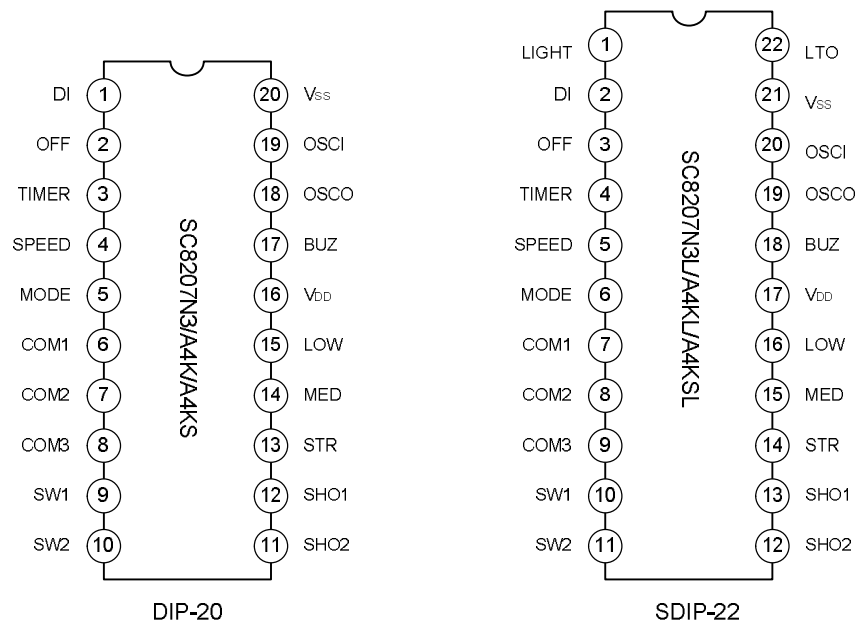
PIN CONFIGURATION

PIN DESCRIPTION

DIP-20 pin no.	SDIP-22 pin no.	Symbol	Description
--	1	LIGHT	Light control key input.
1	2	DI	Remote control sensor input.
2	3	OFF	OFF control key input, shared with LED scan output.
3	4	TIMER	TIMER control key input and LED scan output.
4	5	SPEED	SPEED key control input and LED scan output.
5	6	MODE	MODE key control input and LED scan output.
6	7	COM1	Consumer code C2 select and LED scan common port.
7	8	COM2	Consumer code C1 select and LED scan common port.
8	9	COM3	LED scan common port.
9	10	SW1	LEVEL SWING key control and consumer code select diode connect port.
10	11	SW2	COLD key control (SC8207A4KS) /VERTICAL SWING key control port(N3, A4K)
11	12	SHO2	Cold wind motor /vertical swing drive port
12	13	SHO1	Level swing output port
13	14	STR	Strong wind drive output
14	15	MED	Middle wind drive output
15	16	LOW	Low wind drive output
16	17	V _{DD}	Positive power
17	18	BUZ	Buzzer drive output
18	19	OSCO	455kHz oscillator input/output port
19	20	OSCI	
20	21	V _{SS}	Negative power
--	22	LTO	Light drive output

FUNCTION DESCRIPTIONS

SC8207 is an electronic fan control IC, it use electronic touch switch and timer replace the traditional switch and timer. SC8207 improved nature wind and sleep wind mode except hold the traditional fan functions, and improved two groups of swing control and light control function. SC8206 cooperate with SC5104 encode IC, implement the remote control of the fan.

“OFF” key:

It used to shut down the power of motor, fan stop operating. And the control circuit resume static state, and stored the operate mode of power on. When started next time, it is activated into the operation mode stored in the operation memory (Timer and sleep wind mode will not be stored).

“ON/SPEED” key:

It start fan if pressed when fan is off. It turn on the fan with middle wind for increase start moment. After three second, it resume low wind mode, or the operation mode stored in the operating memory.

This key set the operate mode when fan is on, if successive pressing of ON/SPEED key, it will operate as low wind, middle wind, strong wind, low wind, middle windgo along with cycle.

“ON/OFF” key (extension K)

It start fan if pressed when fan is off. It turn on the fan with middle wind for increase start moment. After three second, it resume low wind mode, or the operation mode stored in the operating memory.

It turn off the power when fan is on, fan stopped, control circuit resume static state, and stored the operate mode into memory. When the fan turn on next time, it start in the operate mode in the memory (timer and sleep mode will not be stored).

“SPEED” key (extension K)

SPEED key is used to turn on the fan change speed of the fan. When successive pressing of SPEED key, fan will operate as follows: low wind, middle wind, strong wind, low wind.....go along with cycle.

“MODE” key:

It used to select the operating mode. If pressed successively when fan is on, it will operate as follows: normally wind, nature wind, sleep wind, normally, nature windgo along with cycle.

- a) Ordinary wind: the he wind speed is set by SPEED key and does not change as time passes.
- b) Nature wind: it is set in program, and operate with “SPEED” key, can produce strong nature wind, middle nature wind, low nature wind, simulate the really nature wind.
- c) Sleep wind: In sleep wind mode, the wind speed steps down automatically one level every interval, until it reaches low wind level.

Where is the rule of down:

- 1) If fan set in strong wind mode at first, it operate in strong nature wind for half an hour, then switch into middle nature wind, after half an hour switch into low nature wind, until the preset time end or turn off fan.
- 2) If fan set in middle wind mode at first, it operates in middle nature wind for half an hour, then switch into low nature wind, until the preset time end or turn off fan.
- 3) If fan set in low nature wind at first, it operates in low nature wind, until the preset time end or turn off.

“TIMER” key:

This key used to set the preset off time.

Type mark with “A4” mean have four section time output (0.5, 1, 2, 4hour) accumulated.

Type mark with “N3” means have three section time output (1, 2, 4 hour) non-accumulated.

When fan is in the time mode, LED will indicate the remain time, means the fan will stop after the display time.

“LEVEL SWING” key:

If pressed when fan is in the operate mode, it can control the fan swing, it is invalid when fan stopped.

“VERTICAL SWING” key:

N3: If pressed when fan is in the operate mode, it can control the fan vertical swing, it is invalid when fan stopped.

A4: If pressed when fan is in the operate mode, it can control the fan vertical swing. If continue pressed, fan up to down swing. When release the key, swing stopped.

“COLD WIND” key:

If pressed when fan is in the operate mode, it can control the fan cold-wind switch, it is invalid when fan stopped.

“LIGHT” key:

It is used to control light, is independent of the operate mode.

Buzzer output:

- a) Turn on send out “Bi-Bi”
- b) Turn off send out “Bi-“
- c) Other available operate (include key press and remote controller receive) send out “Bi”

CONTROL PANEL

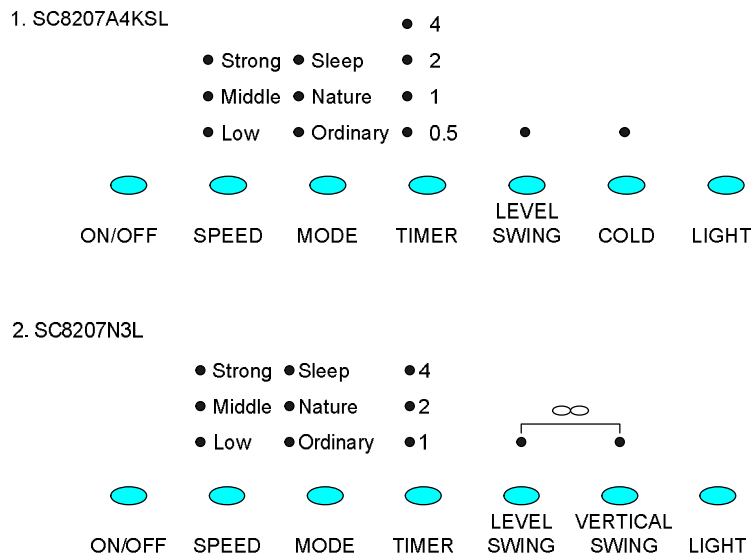

TYPICAL APPLICATION CIRCUIT

Power circuit

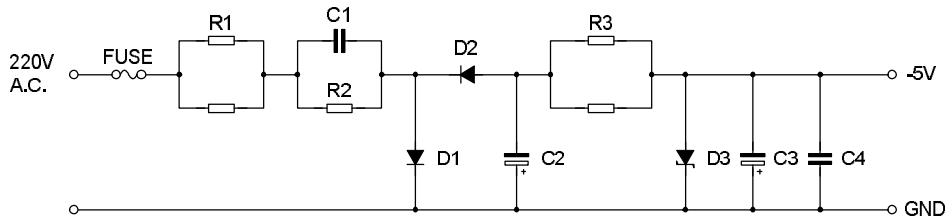

Controller unit

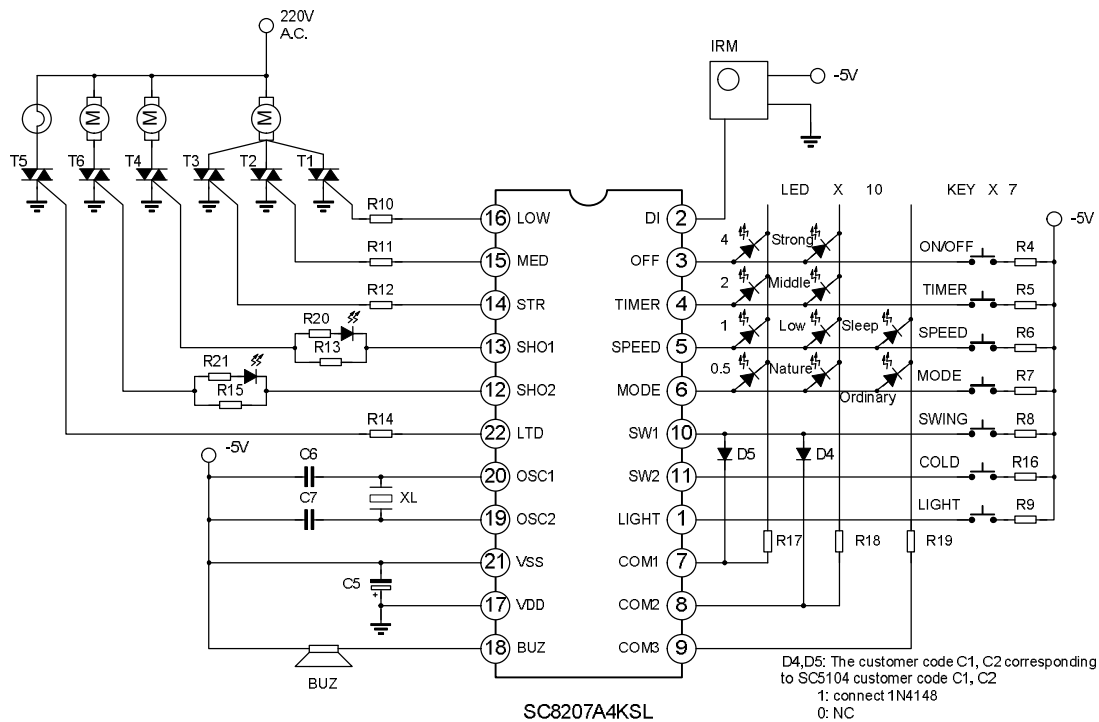

COMPONENTS LIST

Symbol	value	Symbol	value
FUSE	1A, 250V	C4	0.1 μ F,
R1	2x180 Ω /2W	C5	47 μ F, 10V
R2	200k Ω /0.5W	C6, C7	100pF
R3	2x47 Ω /0.25W	D1, D2	1N4007
R4~R9, R16	10K Ω , 0.25W	D3	5.1V, 1W
R10~R15	470 Ω , 0.25W	XL	455KHz
R17~R19	120 Ω , 0.25W	BUZ	ϕ 27
R20, R21	560 Ω , 0.25W	LED	ϕ 3x12
C1	1.2 μ F, 400VAC	D4, D5	1N4148
C2	470 μ F, 16V	KEY	6mmX7
C3	470 μ F, 10V	T1~T6	Z00607MA, MAC97A6

SC5104 transmitter controller unit

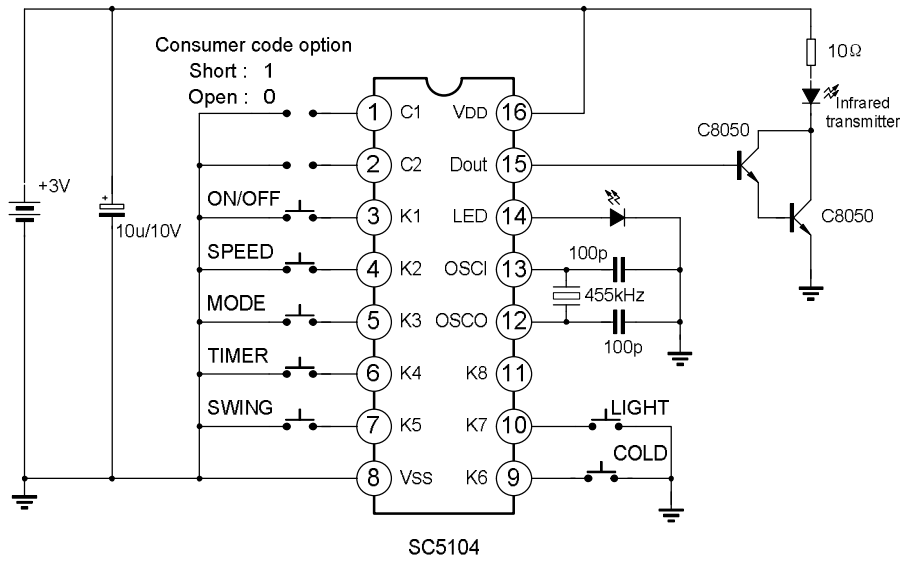

PACKAGE OUTLINE

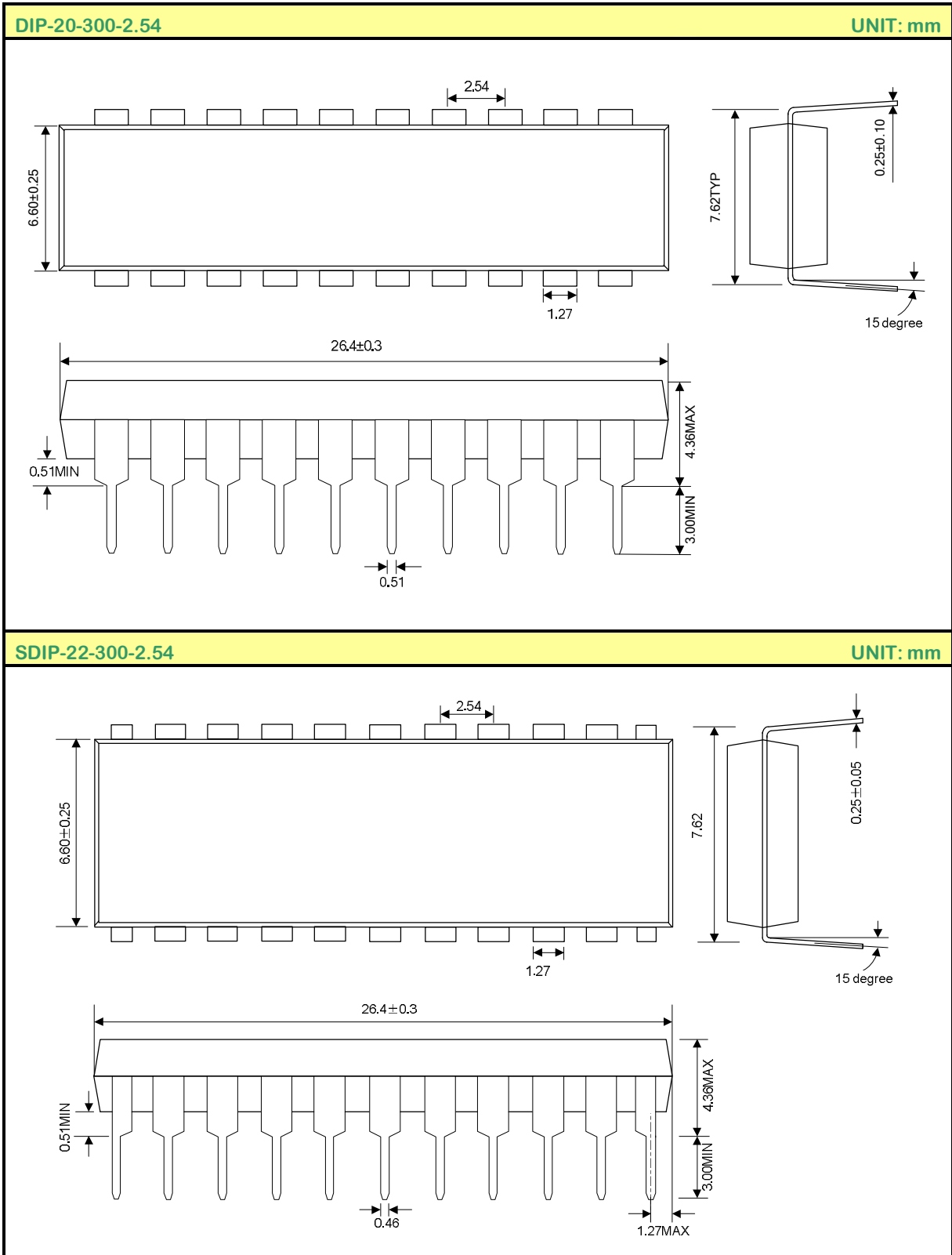



HANDLING MOS DEVICES:

Electrostatic charges can exist in many things. All of our MOS devices are internally protected against electrostatic discharge but they can be damaged if the following precautions are not taken:

- Persons at a work bench should be earthed via a wrist strap.
- Equipment cases should be earthed.
- All tools used during assembly, including soldering tools and solder baths, must be earthed.
- MOS devices should be packed for dispatch in antistatic/conductive containers.