

## Quadruple Rail-to-Rail Operational Amplifiers

### Features

- Wide Supply Operation Range +4.5V to +20V
- Input Common Voltage Range Beyond the Rails
- Rail-to-Rail Output Voltage Swing
- High Peak Source Capability 1300mA
- High Peak Sink Capability 850mA
- Low Input Offset Voltage 3mV (Typical)
- Wide -3dB Bandwidth 35MHz
- Quiescent Current: 8.5mA
- Large DC Voltage Gain 80dB (Typical)
- Slew-Rate 50V/μs
- Unit-Gain Stable

### Applications

- Portable Equipment
- LCD-TV Equipment
- Battery-Powered Equipment
- ASIC Input or Output Amplifier
- Low Power/Low Voltage Applications

### General Description

The G1584 consists of one independent, high gain, internally frequency compensated operational amplifiers which was designed to operate from a single power supply over a wide range of voltages. Operation from split power supplies is also possible. The input common mode range of the G1584 can be beyond the rails, and the G1584 is with rail-to-rails output voltage swing. The quiescent current is 8.5mA, typically.

The G1584 also feature fast slewing and settle-times, as well as high output drive capability of source 1300mA /sink 850mA. These features make this amplifier ideal for use as reference buffers for TFT-LCD. Other applications include battery power, portable devices, and anywhere low power consumption is important.

The G1584 is housed in a TSSOP-14, TSSOP-14 (FD) and TQFN4X4-16 package.

### Ordering Information

ORDER NUMBER	MARKING	TEMP. RANGE	PACKAGE (Green)
G1584D21U	G1584	-40°C~ +85°C	TSSOP-14
G1584FA1U	G1584	-40°C~ +85°C	TSSOP-14 (FD)
G1584R81U	1584	-40°C to +85°C	TQFN4X4-16

Note: D2:TSSOP-14 FA:TSSOP-14 (FD) R8:TQFN4X4-16

1: Bonding Code

U: Tape & Reel

### Pin Configuration

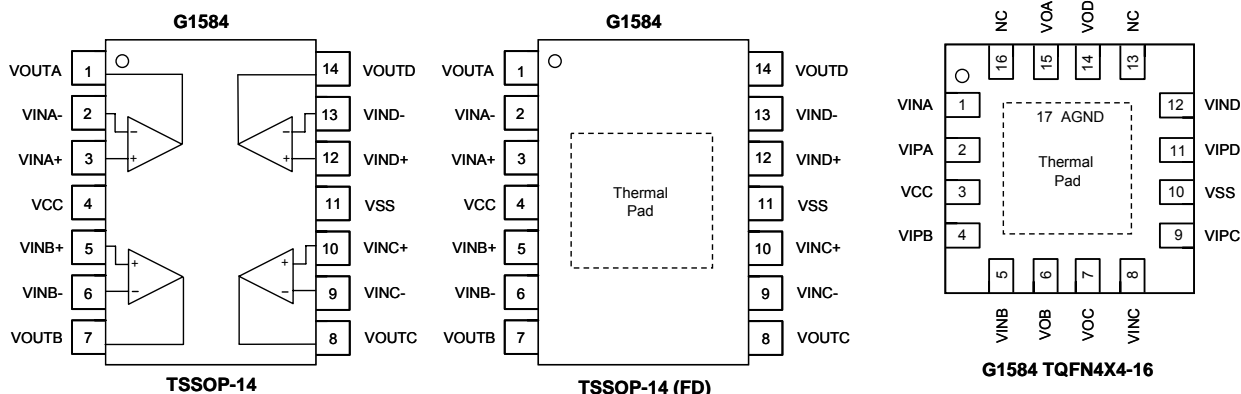

Note: Recommend connecting the Thermal Pad to the Pin#11 VSS for excellent power dissipation.

Note: Recommend connecting the Thermal Pad to the Pin#10 VSS for excellent power dissipation.