

P 2500 A ... P 2500 M

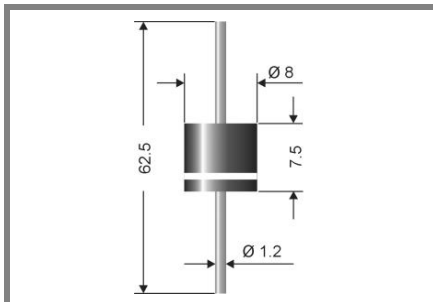

Axial lead diode

Standard silicon rectifier diodes

P 2500 A ... P 2500 M

Forward Current: 25 A

Reverse Voltage: 50 to 1000 V

Features

- Max. solder temperature: 260 °C
- Plastic material has UL classification 94V-0

Mechanical Data

- Plastic case: 8 x 7,5 [mm]
- Weight approx.: 2,4 g
- Terminals: plated terminals solderable per MIL-STD-750
- Mounting position: any
- Standard packaging: 500 pieces per Ammo or 1000 pieces per reel

- 1) Valid, if leads are kept at ambient temperature at a distance of 0 mm from case
- 2) $I_F = 5 \text{ A}$, $T_A = 25 \text{ °C}$, $V_F@25\text{A}$ for types: P2500A-G < 960mV, P2500J-M < 1030mV
- 3) $T_A = 25 \text{ °C}$
- 4) Thermal resistance from junction to lead/terminal at a distance 0 mm from case
- 5) Max. junction temperature $T_j \leq 185 \text{ °C}$ in reverse mode $V_R = 50\% V_{RRM}$, $T_j \leq 200 \text{ °C}$ in bypass mode

Type	Repetitive peak reverse voltage V_{RRM} V	Surge peak reverse voltage V_{RSM} V	Max. reverse recovery time $I_F = - A$ $I_R = - A$ $I_{RR} = - A$ t_{rr} ns	Max. forward voltage $V_F^{(2)}$
P 2500 A	50	50	-	0,85
P 2500 B	100	100	-	0,85
P 2500 D	200	200	-	0,85
P 2500 G	400	400	-	0,85
P 2500 J	600	600	-	0,87
P 2500 K	800	800	-	0,87
P 2500 M	1000	1000	-	0,87

Absolute Maximum Ratings

$T_A = 25 \text{ °C}$, unless otherwise specified

Symbol	Conditions	Values	Units
I_{FAV}	Max. averaged fwd. current, R-load, $T_A = 50 \text{ °C}^1$	25	A
I_{FRM}	Repetitive peak forward current $f > 15 \text{ Hz}^1$	90	A
I_{FSM}	Peak forward surge current 50 Hz half sinus-wave 3	650	A
i^2t	Rating for fusing, $t < 10 \text{ ms}^3$	2100	A ² s
R_{thA}	Max. thermal resistance junction to ambient 1		K/W
R_{thL}	Max. thermal resistance junction to terminals 4	0,8	K/W
T_j	Operating junction temperature	- 50 ... + 175 ($T_j \leq 200 \text{ °C}^5$)	°C
T_s	Storage temperature	- 50 ... + 175	°C

Characteristics

$T_A = 25 \text{ °C}$, unless otherwise specified

Symbol	Conditions	Values	Units
I_R	Maximum leakage current, $T_j = 25 \text{ °C}$; $V_R = V_{RRM}$	<10	µA
	$T_j = \text{°C}$; $V_R = V_{RRM}$		
C_j	Typical junction capacitance (at MHz and applied reverse voltage of V)	-	pF
Q_{rr}	Reverse recovery charge ($U_R = V$; $I_F = A$; $dI_F/dt = A/ms$)	-	µC
E_{RSM}	Non repetitive peak reverse avalanche energy ($I_R = mA$; $T_j = \text{°C}$; inductive load switched off)	-	mJ

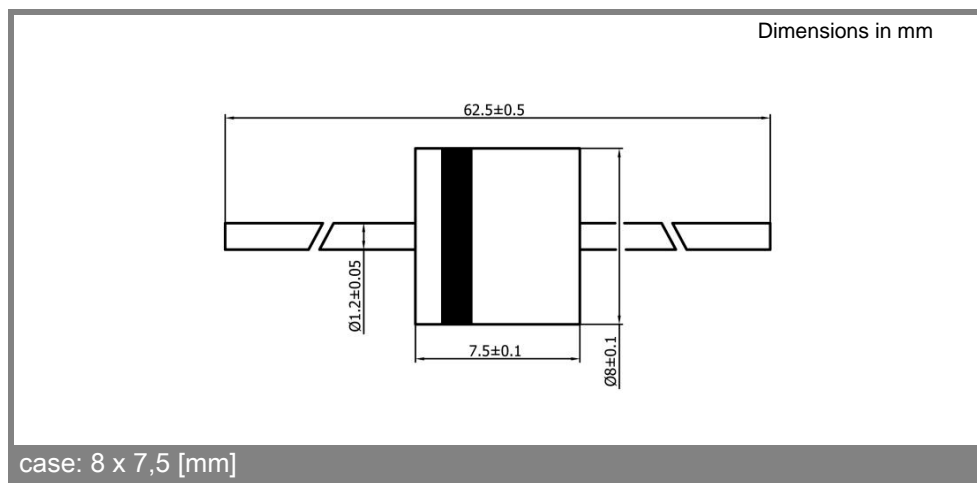

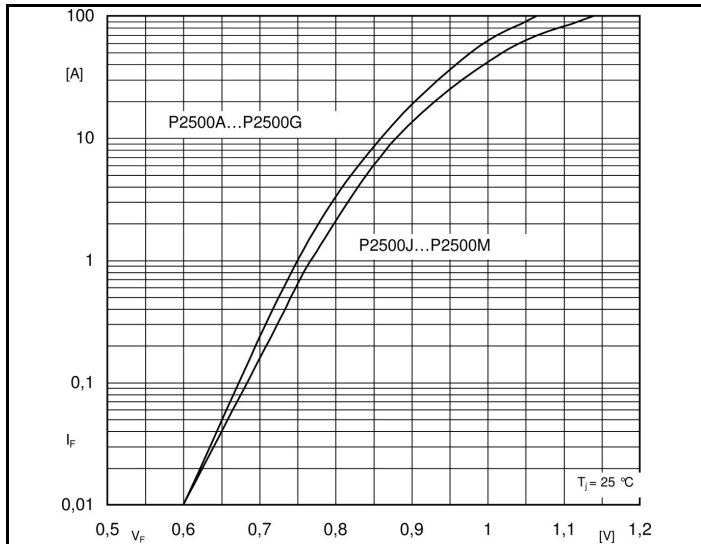

Fig. 1 Forward characteristics (typical values)

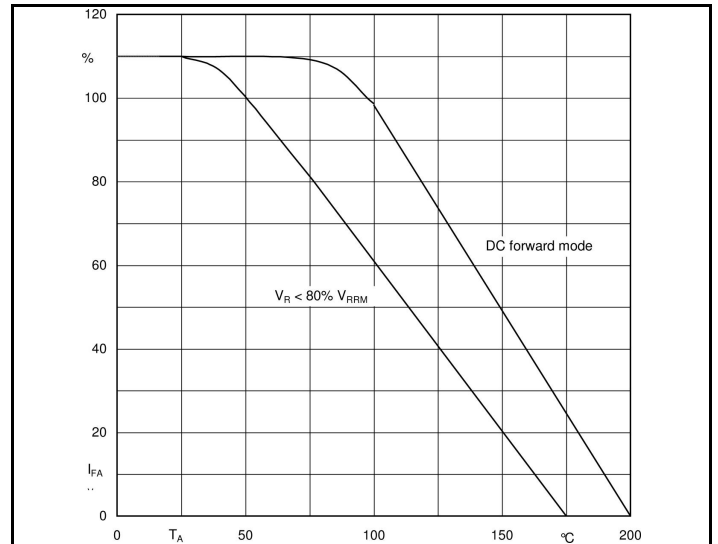

Fig. 2 Rated forward current vs. amb. temperature ¹⁾

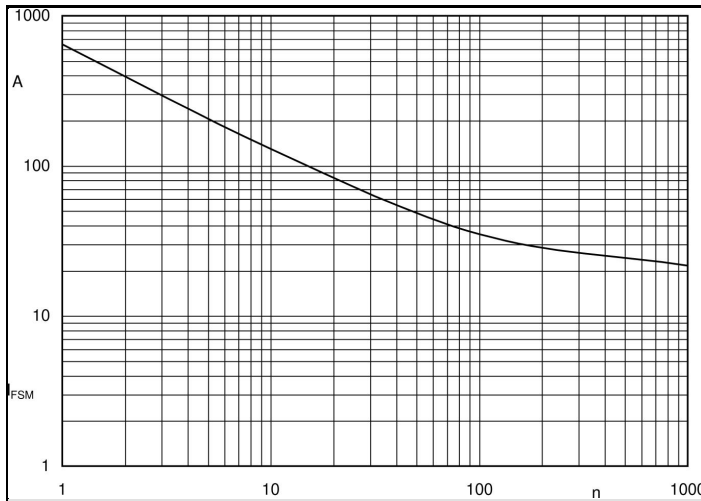

Fig. 3 I_{FSM} current versus number of cycles at 50 Hz

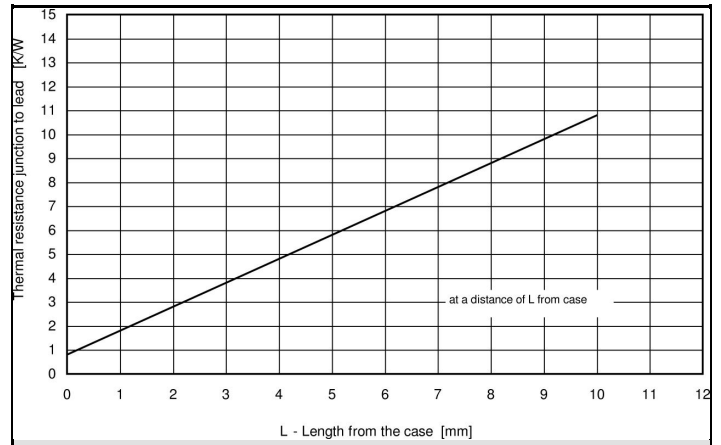

Fig. 4, Thermal resistance versus length from case