



AN1229

APPLICATION NOTE

SD2932 RF MOSFET FOR 300W FM AMPLIFIER

Serge Juhel

1. ABSTRACT

This application note gives a description of a broadband power amplifier operating over the frequency range 88 - 108 MHz and using the new STMicroelectronics RF MOSFET transistor SD2932.

Table 1: Typical Achievable Performances

Device	1 X SD2932
Frequency	88-108 MHz
Vdd	50 V
Idq	200 mA
Pout	300 W
Gain	>19 dB
Input Return Loss	<-11 dB
Drain Efficiency	>70%

2. AMPLIFIER DESIGN.

2.1. Input Matching Network.

Typical input gate to gate impedance of SD2932 at 100 MHz is $Z_{in} = R_s + jX_s = 2 - 2.6 j$, and can also be expressed as the combination of parallel resistance and reactance using the following formulae :

$$R_p = R_s \times [1 + (X_s / R_s)^2] = 5.38 \text{ ohms}$$

$$X_p = R_p / (X_s / R_s) = -4.14 j \text{ ohms}$$

Therefore, in order to achieve good input matching performances over the frequency range 88-108 MHz the unbalanced 50 ohms is to be transformed into an impedance with a value as close as possible to R_p of 5.38 ohms.

From the circuit schematic given in Fig. 6 , we can see that the input matching network is based on a two section balun (1:1 balun in cascade with a 9:1 balun transformer) which will transform the unbalanced 50 ohms to a balanced 5.56 ohms (2 x 2.78 ohms / 9:1 ratio). The first section, a 5" long - 50 ohms coaxial cable and the second section, a two 3.9" long - 25 ohms flexible coaxial cables with ferrite core NEOSIDE, are connected as described: a 10 nH inductor (L1) is connected between the two gates to compensate SD2932 input parallel reactance X_p . quasi-neutral region of the junction. The breakdown-voltage regime is the avalanching of carriers due to the electric field being greater than the critical electric field (approximately 1×10^5 V/cm). Under these conditions an electron can be accelerated by the electric field.

Due to elastic and inelastic scattering this electron acceleration can generate more than one carrier and thus a multiplication scheme transpires.

2.2. Input Matching Network Tuning.

Figure 1: Input Impedance of 1:1 Balun in Cascade with 4:1 Balun

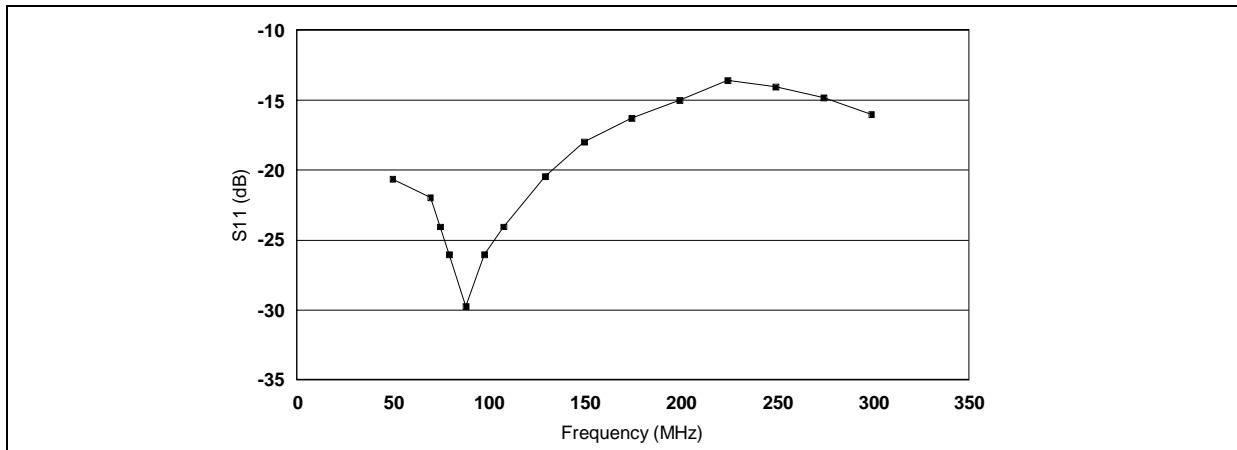
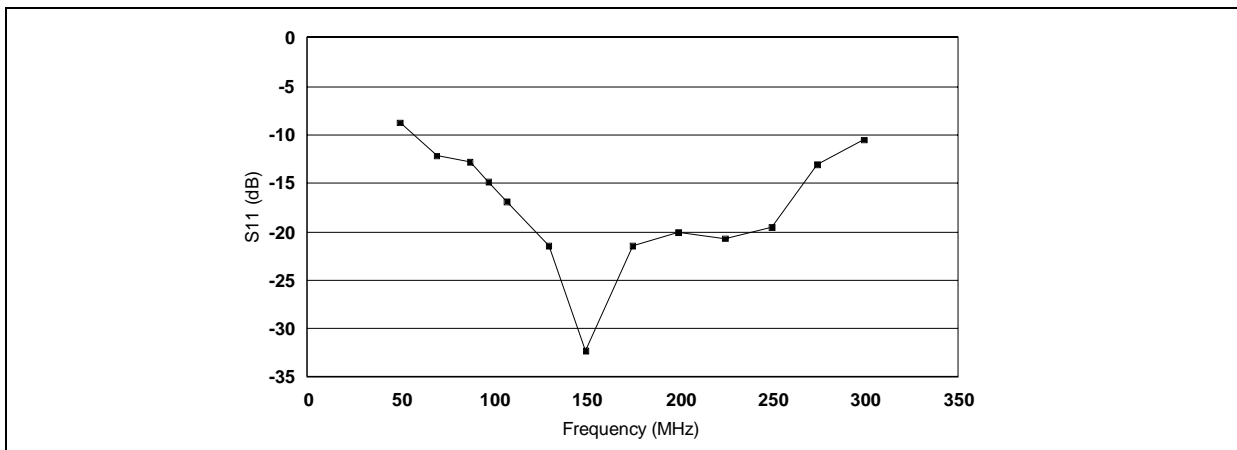

Figure 2: Input Impedance of 1:1 Balun in Cascade with 9:1 Balun



SD2932 input matching network was tuned in order to achieve the best compromise in terms of power gain (Gp) and input return loss (Rtl) over the frequency range 88 - 108 MHz. Best results were achieved by adding a 10 pF chip capacitor (C1) between RFIN and the 1nF blocking capacitor (C2).

2.3. Output Matching Network.

The output impedance of each side is a combination of the output capacitance C_{OSS} (195 pF) and the optimum load resistance which can be determined as follows :

$$R_p = (0.85 \times V_{dd})^2 / (2 \times P_{out}) = (0.85 \times 50V) / (2 \times 150W) = 6.02 \text{ ohms}$$

The total optimum load , seen by SD2932 (drain to drain) , is 2 x 6.02 = 12.04 ohms. Therefore, a simple two section balun (1:1 balun in cascade with a 4:1 balun transformer) is used to transform the unbalanced 50 ohms to a balanced 12.5 ohms (2 x 6.25 ohms) which is very near to the total optimum load resistance.

The first section, a 5" long - 50 ohms flexible coaxial cable, and the second section, two 5" long - 25 ohms flexible coaxial cables, are connected as described in figure 6.

To compensate for the output capacitance C_{OSS} of SD2932 , a 40nH inductor (L2) is connected between the two drains. This LC network (L2 & C_{OSS}) is a high pass filter with a resonance frequency calculated at 10 % below the minimum operating frequency :

$$C_{OSS} = C_{OSS} \text{ (per side)} / 2 = 180 \text{ pF} / 2 = 90 \text{ pF}$$

$$\text{Frequency of resonance} = 0.9 \times 88 \text{ MHz} = 80 \text{ MHz}$$

$$L2 \times C_{OSS} (2\text{pf})^2 = 1 \rightarrow L2 = 44 \text{ nH}$$

Figure 3: Power Gain vs. Frequency

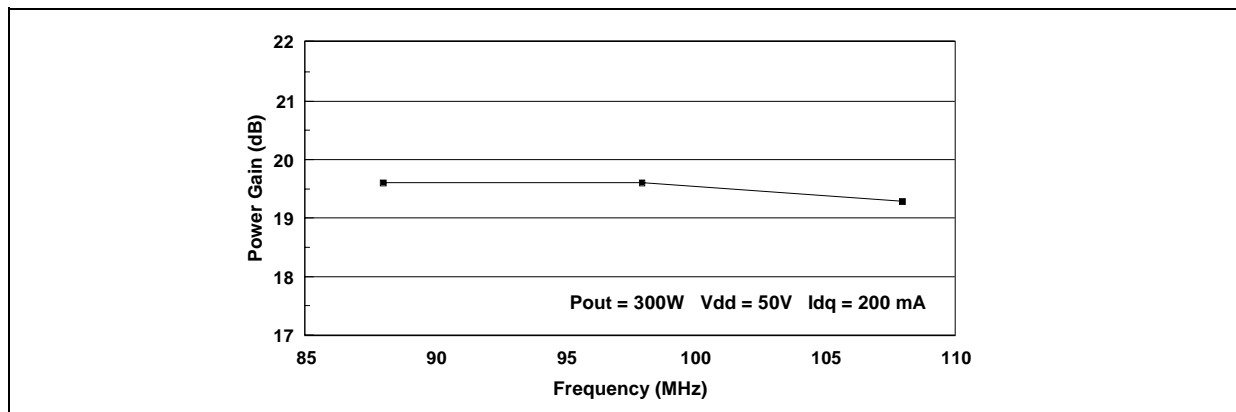

Figure 4: Drain Efficiency vs. Frequency

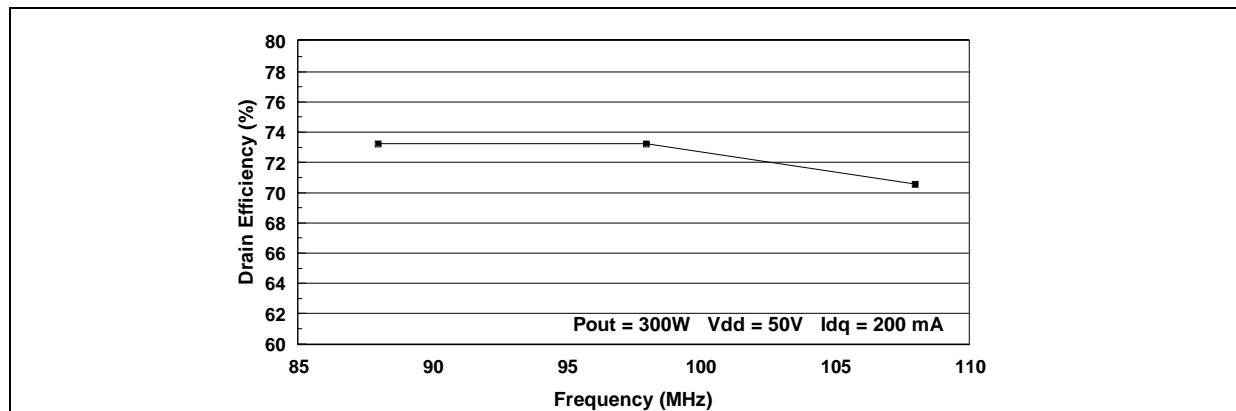
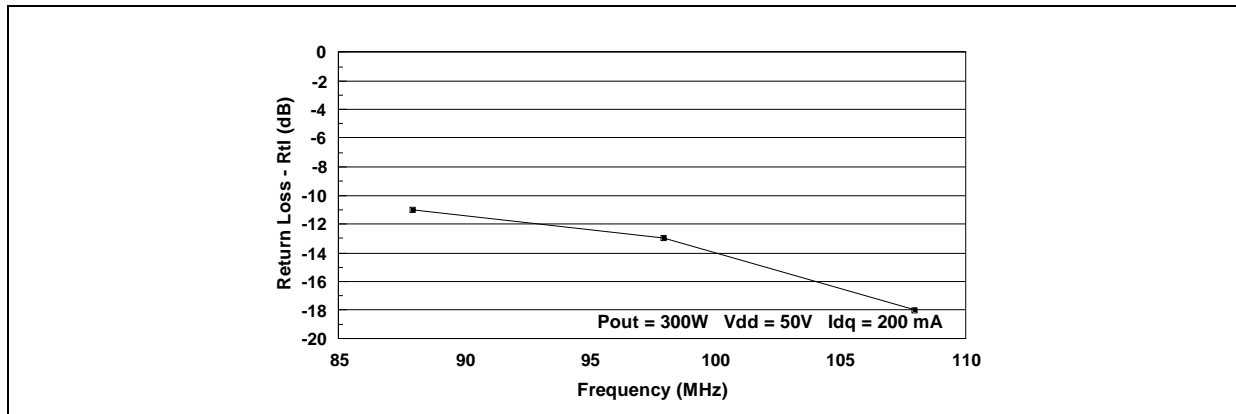

Figure 5: Input Return Loss vs. Frequency



3. MEASURED SD2932 TYPICAL PERFORMANCES AND CONCLUSION.

Figures 3, 4 & 5 show power gain, efficiency and input return loss over the frequency range 88 - 108 MHz at a constant output power of 300 Watts and a drain supply voltage of 50 Volts and a quiescent current of 200 mA. Typical performances are as follows:

Table 2.

	MIN	MAX
Gp	19.3dB	19.6dB
R _{TL}	-18dB	-11dB
Eff	71%	73%

Finally, in this report we have demonstrated ST SD2932 MOSFET transistor excellent performance as a wide band 300W - 50V push-pull amplifier for FM applications.

Figure 6: 88-108MHz Circuit Schematic

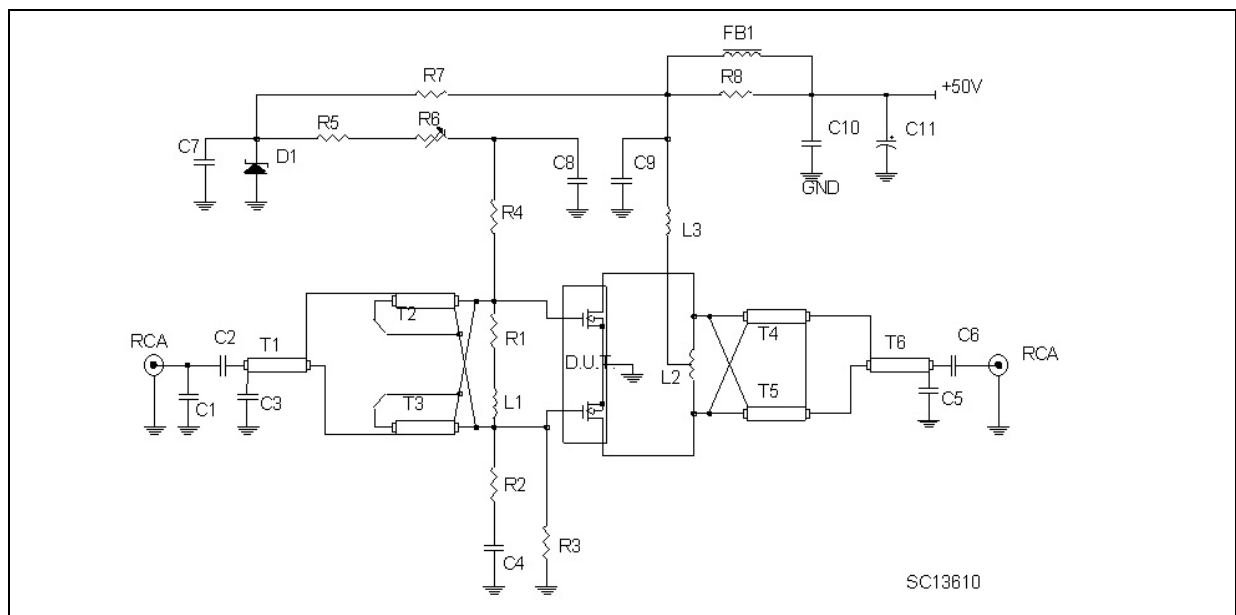

Table 3: 88-108MHz Circuit Components List

PCB	1/32" Woven Fiberglass 0.0030 Cu, 2 side, $\epsilon_r = 4.8$
T1	50 Ohm Flexible Coax Cable OD 0.006", 5" Long
T2/ T3	9:1 Transformer, 25 Ohm Flexible Coax Cable OD 0.1" 3.9". Ferrite Core NEOSIDE
T4 / T5	4:1 Transformer, 25 Ohm Flexible Coax Cable OD 0.1" 5.0" Long.
T6	50 Ohm Flexible Coax Cable OD 0.1" 5.0" Long.
FB1	VK200
C1	10pf Ceramic Capacitor
C2/C3/C4/C7/C8	1 nF Chip Capacitor
C5/C6	1 nF ATC chip Capacitor
C9	470 pF ATC Chip Capacitor
C10	100 nF Chip Capacitor
R1	56 Ohm Resistor
R2/R4	10 Ohm Chip Resistor
R3	10K Ohm Resistor
R5	5.6K Ohm Resistor
R6	10K Ohm. 10 Turn Trim Resistor
R7	3.3K Ohm/ 1 W Resistor
R8	15 Ohm/ 1 W Resistor
D1	6.8 V Zener Diode
L1	10 nH Inductor
L2	40 nH Inductor
L3	70 nH Inductor

Information furnished is believed to be accurate and reliable. However, STMicroelectronics assumes no responsibility for the consequences of use of such information nor for any infringement of patents or other rights of third parties which may result from its use. No license is granted by implication or otherwise under any patent or patent rights of STMicroelectronics. Specification mentioned in this publication are subject to change without notice. This publication supersedes and replaces all information previously supplied. STMicroelectronics products are not authorized for use as critical components in life support devices or systems without express written approval of STMicroelectronics.

The ST logo is a trademark of STMicroelectronics

© 2000 STMicroelectronics - Printed in Italy - All rights reserved

STMicroelectronics GROUP OF COMPANIES

Australia - Brazil - China - Finland - France - Germany - Hong Kong - India - Italy - Japan - Malaysia - Malta - Morocco - Singapore - Spain - Sweden - Switzerland - United Kingdom - U.S.A.

<http://www.st.com>