



1N70

Power MOSFET

1.2A, 700V N-CHANNEL POWER MOSFET

DESCRIPTION

The UTC **1N70** is a high voltage MOSFET and is designed to have better characteristics, such as fast switching time, low gate charge, low on-state resistance and have a high rugged avalanche characteristics. This power MOSFET is usually used at high speed switching applications in power supplies, PWM motor controls, high efficient DC to DC converters and bridge circuits.

FEATURES

- * $R_{DS(ON)} = 13.5\Omega @ V_{GS} = 10V$.
- * Ultra Low gate charge (typical 5.0nC)
- * Low reverse transfer capacitance ($C_{RSS} =$ typical 3.0 pF)
- * Fast switching capability
- * Avalanche energy specified
- * Improved dv/dt capability, high ruggedness

SYMBOL

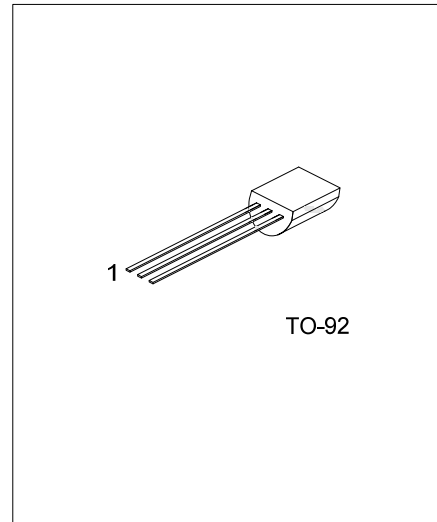
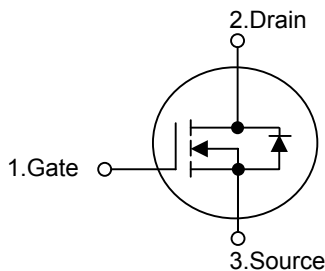

ORDERING INFORMATION

Ordering Number		Package	Pin Assignment			Packing
Lead Free	Halogen Free		1	2	3	
1N70L-T92-B	1N70G-T92-B	TO-92	G	D	S	Tape Box
1N70L-T92-K	1N70G-T92-K	TO-92	G	D	S	Bulk
1N70L-T92-R	1N70G-T92-R	TO-92	G	D	S	Tape Reel

<p>1N70L-T92-B</p> <p>(1)Packing Type (2)Package Type (3)Lead Free</p>	<p>(1) B: Tape Box, K: Bulk, T: Tube, R: Tape Reel (2) T92: TO-92 (3) G: Halogen Free, L: Lead Free</p>
--	---

■ ABSOLUTE MAXIMUM RATINGS ($T_C = 25^\circ\text{C}$, unless otherwise specified)

PARAMETER	SYMBOL	RATINGS	UNIT
Drain-Source Voltage	V_{DSS}	700	V
Gate-Source Voltage	V_{GSS}	± 30	V
Avalanche Current (Note 2)	I_{AR}	1.2	A
Continuous Drain Current	I_D	1.2	A
Pulsed Drain Current (Note 2)	I_{DM}	4.8	A
Avalanche Energy	Single Pulsed (Note 3)	E_{AS}	50
	Repetitive (Note 2)	E_{AR}	4.0
Peak Diode Recovery dv/dt (Note 4)	dv/dt	4.5	V/ns
Power Dissipation	P_D	3	W
Junction Temperature	T_J	+150	$^\circ\text{C}$
Operating Temperature	T_{OPR}	-55 ~ +150	$^\circ\text{C}$
Storage Temperature	T_{STG}	-55 ~ +150	$^\circ\text{C}$

Notes: 1. Absolute maximum ratings are those values beyond which the device could be permanently damaged.

Absolute maximum ratings are stress ratings only and functional device operation is not implied.

2. Repetitive Rating: Pulse width limited by maximum junction temperature

3. $L = 60\text{mH}$, $I_{AS} = 1\text{A}$, $V_{DD} = 50\text{V}$, $R_G = 25\Omega$, Starting $T_J = 25^\circ\text{C}$

4. $I_{SD} \leq 1.2\text{A}$, $di/dt \leq 200\text{A}/\mu\text{s}$, $V_{DD} \leq BV_{DSS}$, Starting $T_J = 25^\circ\text{C}$

■ THERMAL DATA

PARAMETER	SYMBOL	RATINGS	UNIT
Junction to Ambient	θ_{JA}	79	$^\circ\text{C}/\text{W}$
Junction to Case	θ_{Jc}	29	$^\circ\text{C}/\text{W}$

■ ELECTRICAL CHARACTERISTICS (T_C=25°C, unless otherwise specified.)

PARAMETER	SYMBOL	TEST CONDITIONS	MIN	TYP	MAX	UNIT
OFF CHARACTERISTICS						
Drain-Source Breakdown Voltage	BV _{DSS}	V _{GS} = 0V, I _D = 250μA	700			V
Drain-Source Leakage Current	I _{DSS}	V _{DS} = 700V, V _{GS} = 0V			10	μA
Gate-Source Leakage Current	Forward	I _{GSS}			100	nA
	Reverse				V _{GS} = 30V, V _{DS} = 0V	
Breakdown Voltage Temperature Coefficient	ΔBV _{DSS} /ΔT _J	I _D = 250μA		0.4		V/°C
ON CHARACTERISTICS						
Gate Threshold Voltage	V _{GS(TH)}	V _{DS} = V _{GS} , I _D = 250μA	2.0		4.0	V
Static Drain-Source On-State Resistance	R _{DS(ON)}	V _{GS} = 10V, I _D = 0.6A		9.3	13.5	Ω
DYNAMIC CHARACTERISTICS						
Input Capacitance	C _{ISS}	V _{DS} =25V, V _{GS} =0V, f=1MHz		120	150	pF
Output Capacitance	C _{OSS}			20	25	pF
Reverse Transfer Capacitance	C _{RSS}			3.0	4.0	pF
SWITCHING CHARACTERISTICS						
Turn-On Delay Time	t _{D(ON)}	V _{DD} =350V, I _D =1.2A, R _G =50Ω (Note 2,3)		5	20	ns
Turn-On Rise Time	t _R			25	60	ns
Turn-Off Delay Time	t _{D(OFF)}			7	25	ns
Turn-Off Fall Time	t _F			25	60	ns
Total Gate Charge	Q _G	V _{DS} =560V, V _{GS} =10V, I _D =1.2A (Note 2,3)		5.0	6.0	nC
Gate-Source Charge	Q _{GS}			1.0		nC
Gate-Drain Charge	Q _{GD}			2.6		nC
SOURCE-DRAIN DIODE RATINGS AND CHARACTERISTICS						
Drain-Source Diode Forward Voltage	V _{SD}	V _{GS} =0V, I _S = 1.2A			1.4	V
Maximum Continuous Drain-Source Diode Forward Current	I _S				1.2	A
Maximum Pulsed Drain-Source Diode Forward Current	I _{SM}				4.8	A
Reverse Recovery Time	t _{rr}	V _{GS} =0V, I _S = 1.2A		160		ns
Reverse Recovery Charge	Q _{RR}	dI _F /dt = 100A/μs (Note1)		0.3		μC

Notes: 1. Repetitive Rating: Pulse width limited by maximum junction temperature

2. Pulse Test: Pulse Width ≤300μs, Duty Cycle ≤2%

3. Essentially Independent of Operating Temperature

■ TEST CIRCUITS AND WAVEFORMS

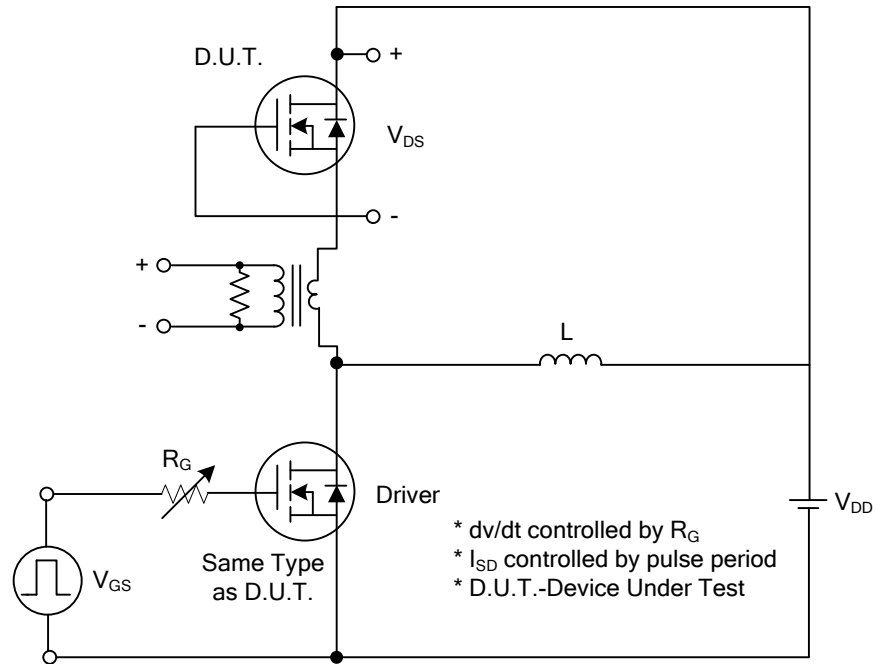

Peak Diode Recovery dv/dt Test Circuit

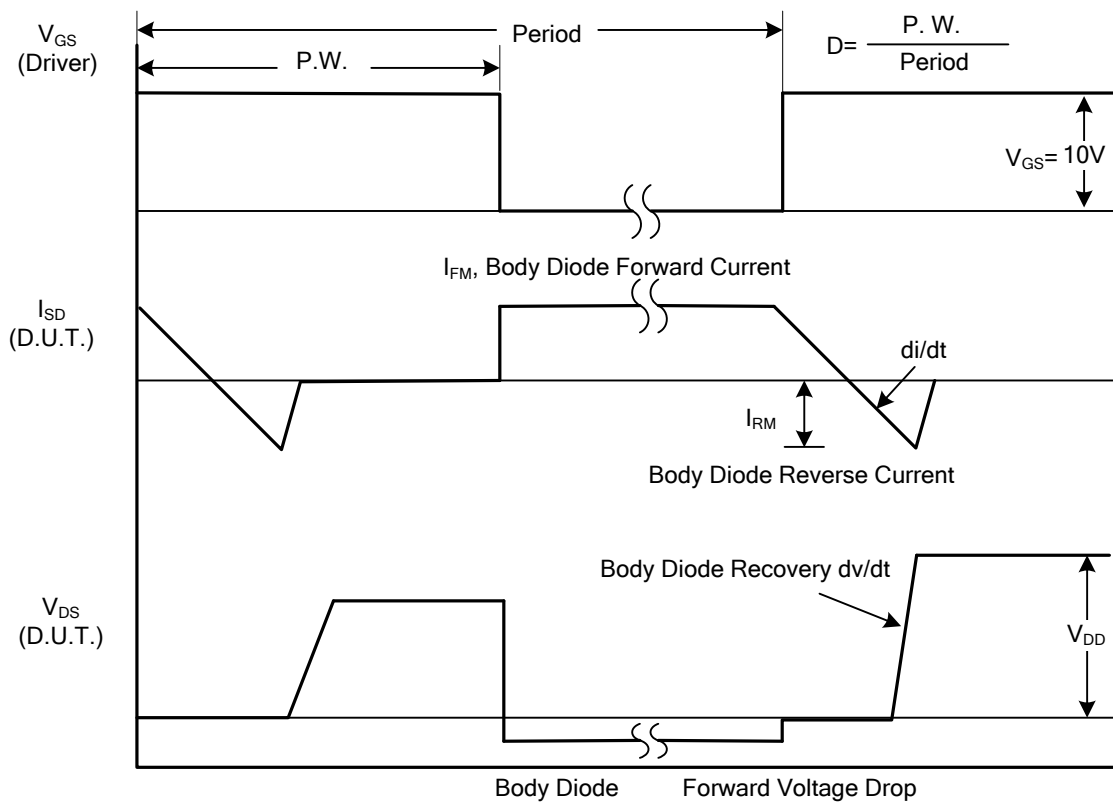

Peak Diode Recovery dv/dt Waveforms

■ TEST CIRCUITS AND WAVEFORMS (Cont.)

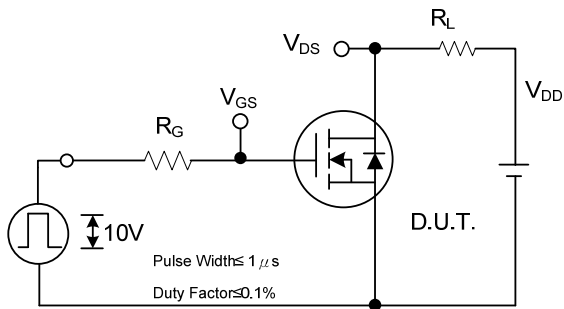

Switching Test Circuit

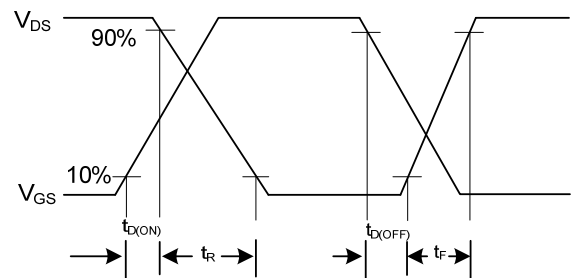

Switching Waveforms

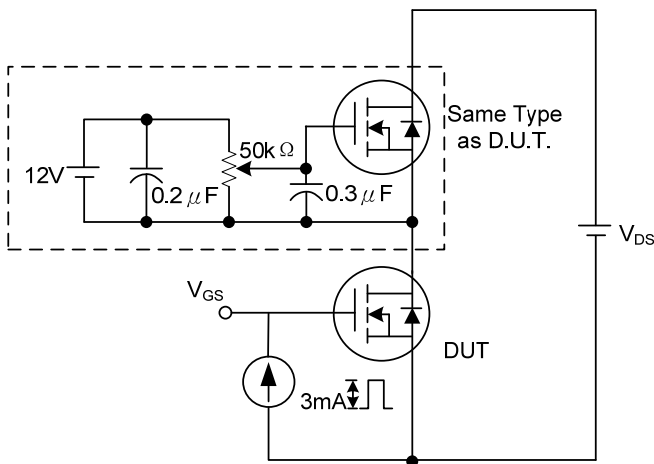

Gate Charge Test Circuit

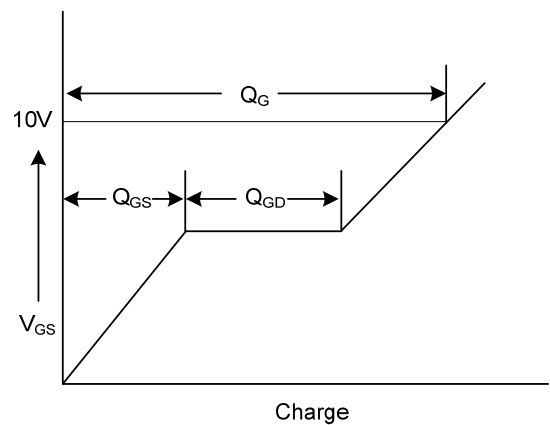

Gate Charge Waveform

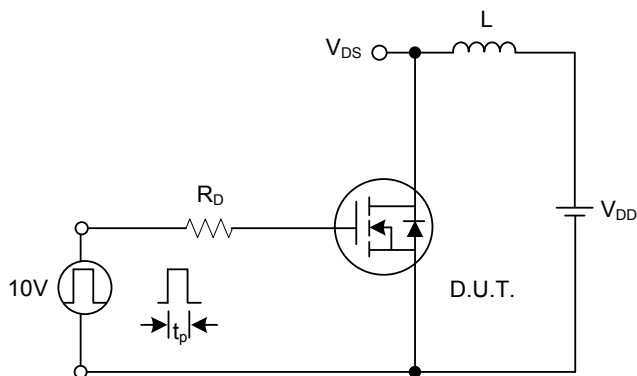

Unclamped Inductive Switching Test Circuit

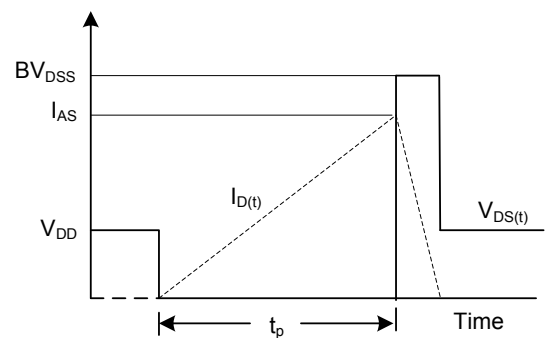

Unclamped Inductive Switching Waveforms

TYPICAL CHARACTERISTICS

Output Characteristics

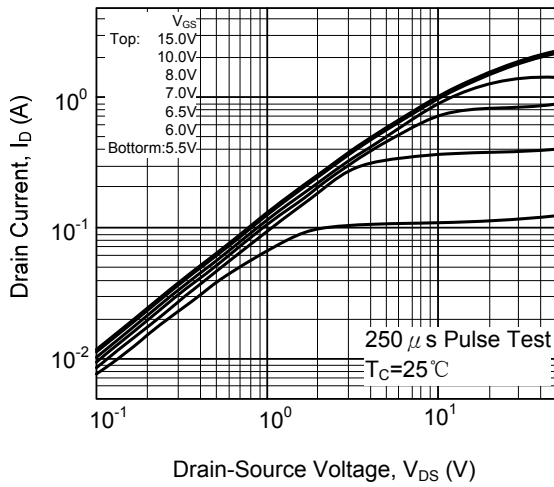

Transfer Characteristics

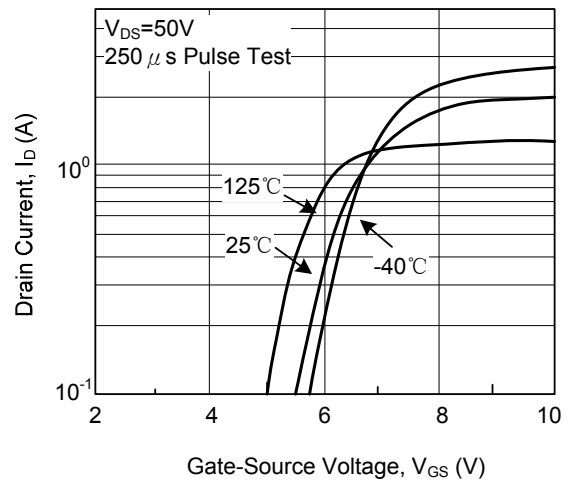

On-Resistance vs. Drain Current

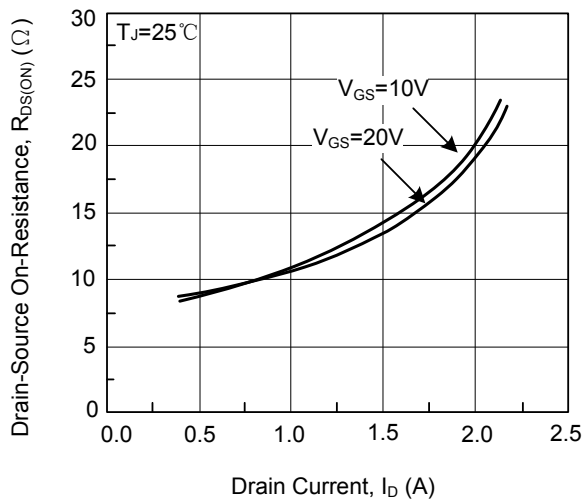

Source- Drain Diode Forward Voltage

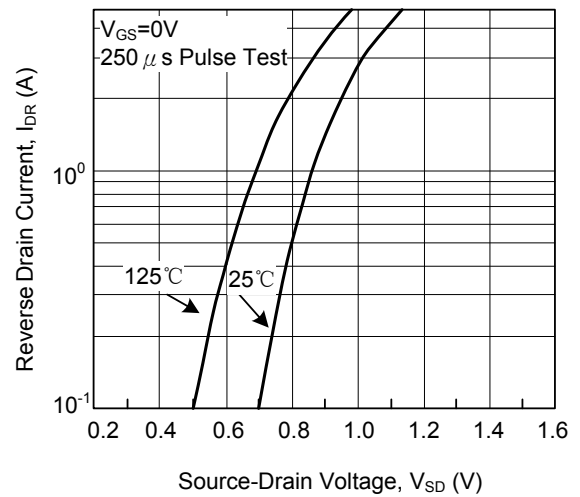

Capacitance vs. Drain-Source Voltage

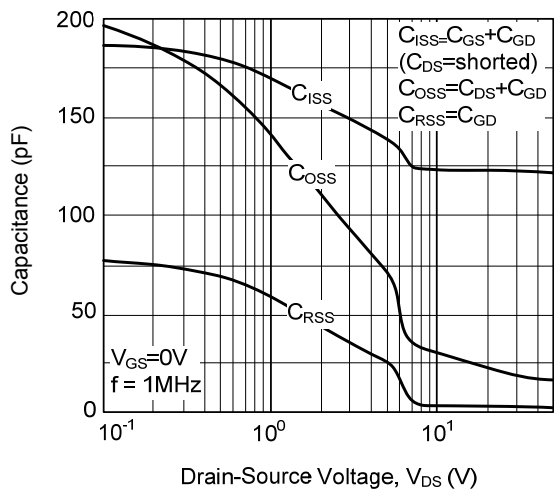

Gate Charge vs. Gate-Source Voltage

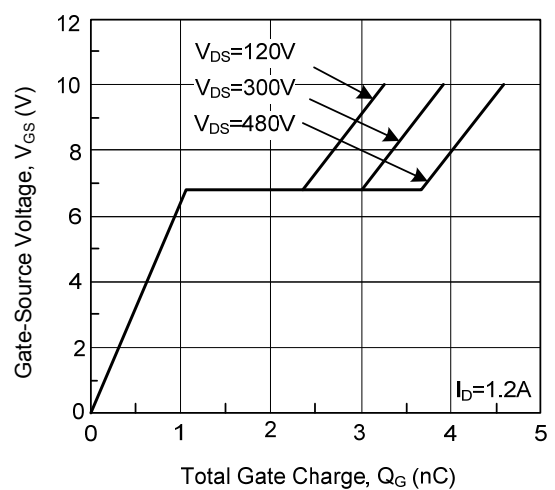

TYPICAL CHARACTERISTICS(Cont.)

Breakdown Voltage vs. Temperature

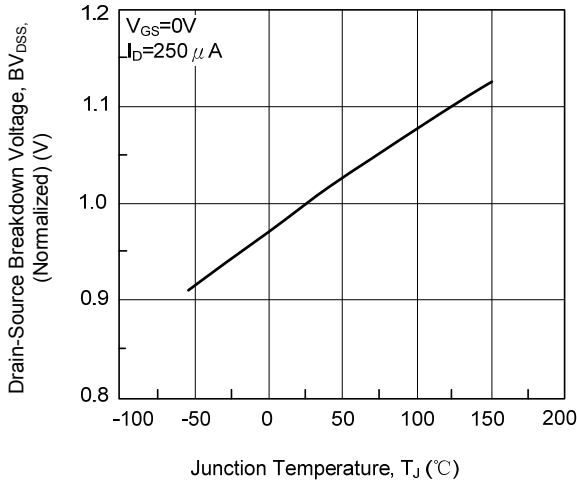

On-Resistance vs. Temperature

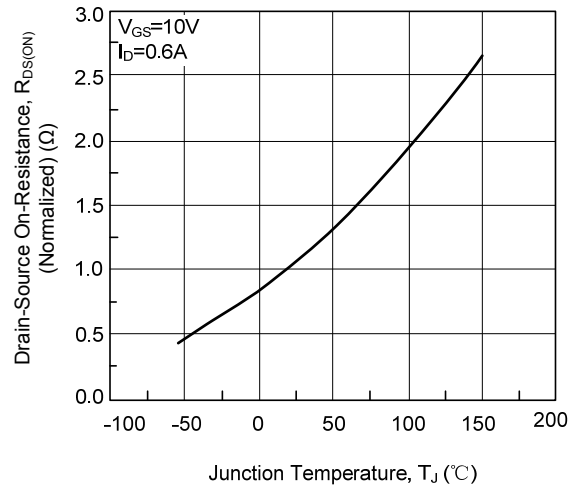

Max. Safe Operating Area

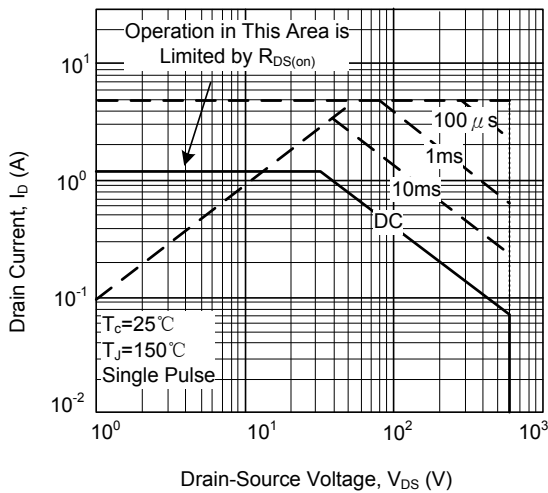

Max. Drain Current vs. Case Temperature

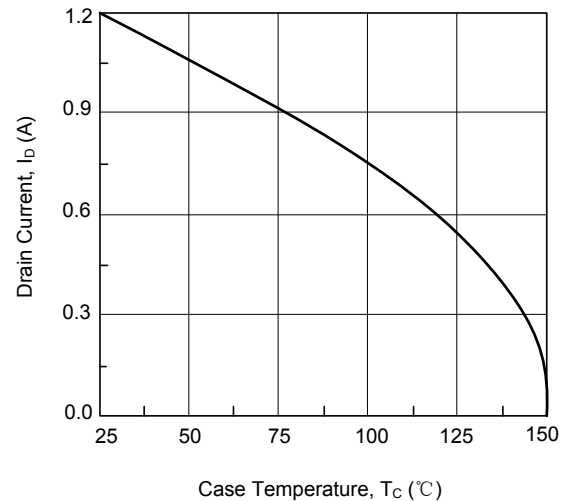

Thermal Response

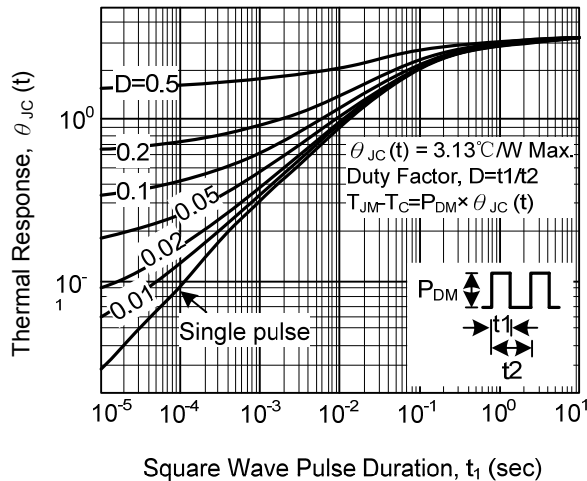

UTC assumes no responsibility for equipment failures that result from using products at values that exceed, even momentarily, rated values (such as maximum ratings, operating condition ranges, or other parameters) listed in products specifications of any and all UTC products described or contained herein. UTC products are not designed for use in life support appliances, devices or systems where malfunction of these products can be reasonably expected to result in personal injury. Reproduction in whole or in part is prohibited without the prior written consent of the copyright owner. The information presented in this document does not form part of any quotation or contract, is believed to be accurate and reliable and may be changed without notice.