

**PLEASE CHECK WWW.MOLEX.COM FOR LATEST PART INFORMATION**

**Part Number:** [0191930293](#)  
**Status:** **Active**  
**Description:** VersaKrimp™ Ring Tongue Terminal for 4 AWG Wire

**Documents:**

[Drawing \(PDF\)](#) [RoHS Certificate of Compliance \(PDF\)](#)

**Agency Certification**

CSA LR18689  
 UL E32244

**General**

Product Family Ring and Spade Terminals  
 Series [19193](#)  
 Crimp Quality Equipment Yes  
 Mil-Spec N/A  
 Product Name VersaKrimp™  
 Type Ring

**Physical**

Barrel Type Closed - Brazed  
 Insulation None  
 Material - Plating Mating Tin  
 Packaging Type Bag  
 Plating min: Mating (µin) 100  
 Plating min: Mating (µm) 2.5  
 Plating min: Termination (µin) 100  
 Plating min: Termination (µm) 2.5  
 Stud Size 5/8" (M16)  
 Termination Interface: Style Crimp or Compression  
 Wire Size AWG 4

**Material Info**

Old Part Number F-370-58

**Reference - Drawing Numbers**

Sales Drawing SD-19193-006

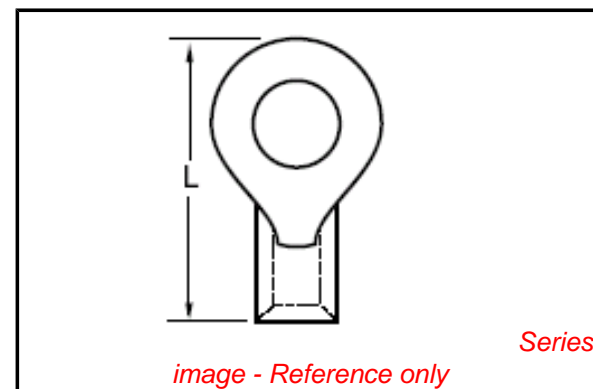

image - Reference only

**EU RoHS**

**ELV and RoHS Compliant**  
**REACH SVHC Contains SVHC: No**  
**Halogen-Free Status**  
**Not Reviewed**

**China RoHS**



**Need more information on product environmental compliance?**

Email [productcompliance@molex.com](mailto:productcompliance@molex.com)  
 For a multiple part number RoHS Certificate of Compliance, [click here](#)

Please visit the [Contact Us](#) section for any non-product compliance questions.

**Search Parts in this Series**

[19193Series](#)

**Application Tooling | [FAQ](#)**

*Tooling specifications and manuals are found by selecting the products below. Crimp Height Specifications are then contained in the Application Tooling Specification document.*

**Global**

Description	Product #
Putt Pump Dieless Head System	<a href="#">0192860065</a>
Manual tool for Crimping non-insulated 8AWG thru 4/0 Terminals	<a href="#">0192940008</a>
Manual Putt Pump Hydraulic System, Die set required	<a href="#">0192860117</a>
Die Set (large) for the HHLS Hydraulic Crimper	<a href="#">0192900007</a>
Hand Crimp Tool	<a href="#">0640013900</a>

This document was generated on 04/14/2010

**PLEASE CHECK [WWW.MOLEX.COM](http://WWW.MOLEX.COM) FOR LATEST PART INFORMATION**

Customer Dwg:

MATERIAL: Copper  
 PLATING: Electro-Tin  
 STUD SIZE: "D" ±.005

- 10 - .198
- 14 - .265
- 56 - .328
- 38 - .390
- 76 - .453
- 12 - .515
- 58 - .656
- 34 - .781
- 209 = .209
- 413 = .413

VERSAKRIMP

BRAZE SEAM

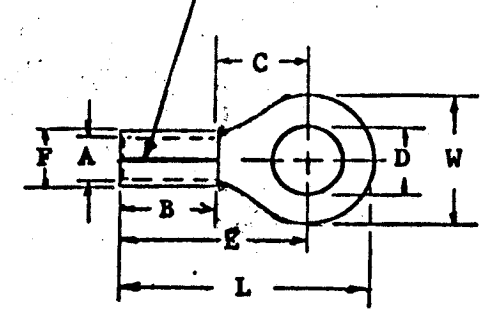

Customer Dimensions

Part No.	Wire Size	"W"	"C" Min	"E" Max	"B" Min	"L" Max	"A" Min	Stock Thkns. (A)	"F" Max	AVAILABLE STUD SIZE
F-366-	#4	.652 .678	.520	1.028	.425	1.385	.280	REF. .075	.470	209, 413 10, 14, 56, 38, 76, 12,
F-367-	#4	.465 .485	.520	1.028	.425	1.288	.280	REF. .075	.470	10, 14, 56
F-369-	#4	.875 .895	.989	1.497	.425	1.970	.280	REF. .075	.470	14, 56, 38, 76, 12, 58
F-370-	#4	1.250 1.270	.989	1.497	.425	2.158	.280	REF. .075	.470	14, 56, 38, 76, 12, 58, 34

For parts to be on tape add "T" at end of part number.



TITLE: "F" RING TONGUE TERMINAL

DIMENSIONAL TOLERANCE UNLESS OTHERWISE SPECIFIED		
FRAC.	DEC.	ANG.
±	±	±

REVISION	SCALE: NONE	DATE
	DRWN. BY: LEM	3/2/70
	CHKD. BY:	
	APPRD. BY:	
A	ETC 50245 11/2 RGM	DRAWING NO.: