

CJD31C NPN  
CJD32C PNP

**SURFACE MOUNT  
COMPLEMENTARY SILICON  
POWER TRANSISTORS**



www.centrasemi.com

**DPAK  
POWER!**

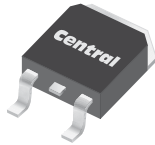

**DPAK TRANSISTOR CASE**

**DESCRIPTION:**

The CENTRAL SEMICONDUCTOR CJD31C, CJD32C types are Complementary Silicon Power Transistors manufactured by the epitaxial base process, mounted in a surface mount package designed for power amplifier and high speed switching applications.

**MARKING: FULL PART NUMBER**

**MAXIMUM RATINGS:** ( $T_C=25^\circ\text{C}$  unless otherwise noted)

	SYMBOL		UNITS
Collector-Base Voltage	$V_{CBO}$	100	V
Collector-Emitter Voltage	$V_{CEO}$	100	V
Emitter-Base Voltage	$V_{EBO}$	5.0	V
Continuous Collector Current	$I_C$	3.0	A
Peak Collector Current	$I_{CM}$	5.0	A
Continuous Base Current	$I_B$	1.0	A
Power Dissipation	$P_D$	15	W
Power Dissipation ( $T_A=25^\circ\text{C}$ )	$P_D$	1.56	W
Operating and Storage Junction Temperature	$T_J, T_{stg}$	-65 to +150	$^\circ\text{C}$
Thermal Resistance	$\theta_{JC}$	8.33	$^\circ\text{C/W}$
Thermal Resistance	$\theta_{JA}$	80.1	$^\circ\text{C/W}$

**ELECTRICAL CHARACTERISTICS:** ( $T_C=25^\circ\text{C}$  unless otherwise noted)

SYMBOL	TEST CONDITIONS	MIN	MAX	UNITS
$I_{CEO}$	$V_{CE}=60\text{V}$		50	$\mu\text{A}$
$I_{CES}$	$V_{CE}=100\text{V}$		20	$\mu\text{A}$
$I_{EBO}$	$V_{EB}=5.0\text{V}$		1.0	mA
$BV_{CEO}$	$I_C=30\text{mA}$	100		V
$V_{CE(SAT)}$	$I_C=3.0\text{A}, I_B=375\text{mA}$		1.2	V
$V_{BE(ON)}$	$V_{CE}=4.0\text{V}, I_C=3.0\text{A}$		1.8	V
$h_{FE}$	$V_{CE}=4.0\text{V}, I_C=1.0\text{A}$	25		
$h_{FE}$	$V_{CE}=4.0\text{V}, I_C=3.0\text{A}$	10	50	
$f_T$	$V_{CE}=10\text{V}, I_C=500\text{mA}, f=1.0\text{MHz}$	3.0		MHz
$h_{fe}$	$V_{CE}=10\text{V}, I_C=500\text{mA}, f=1.0\text{kHz}$	20		

R2 (4-January 2010)

CJD31C NPN  
CJD32C PNP



**SURFACE MOUNT  
COMPLEMENTARY SILICON  
POWER TRANSISTORS**

**DPAK TRANSISTOR CASE - MECHANICAL OUTLINE**

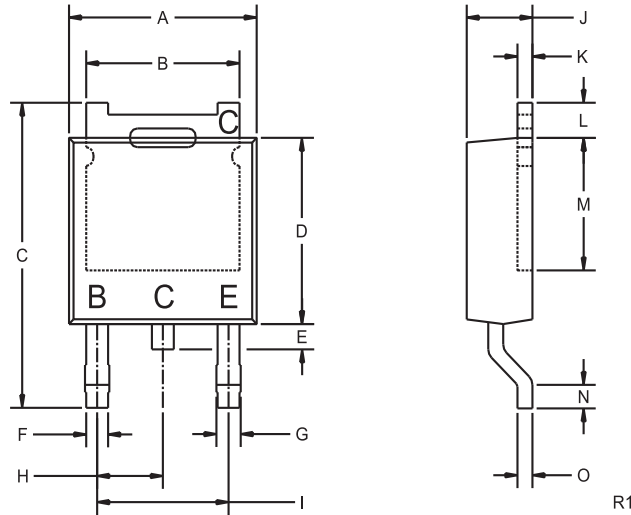

DIMENSIONS				
SYMBOL	INCHES		MILLIMETERS	
	MIN	MAX	MIN	MAX
A	0.250	0.265	6.35	6.73
B	0.205	0.215	5.21	5.46
C	0.374	0.409	9.50	10.40
D	0.235	0.245	5.97	6.22
E	0.025	0.040	0.64	1.02
F	0.025	0.035	0.64	0.88
G	0.030	0.045	0.76	1.14
H	0.090		2.28	
I	0.180		4.57	
J	0.086	0.094	2.19	2.38
K	0.018	0.023	0.46	0.58
L	0.040	0.050	1.02	1.27
M	0.170	-	4.32	-
N	0.020	-	0.51	-
O	0.018	0.023	0.46	0.58

**LEAD CODE:**  
B) BASE  
C) COLLECTOR  
E) EMITTER  
C) COLLECTOR

**MARKING:**  
**FULL PART NUMBER**

DPAK TRANSISTOR (REV: R1)

R2 (4-January 2010)