

構造(Structure): シリコンモノリシック集積回路 (Silicon Monolithic Integrated Circuit)

製品名(Product) : 7.1ch モードセクタ・入力セクタ内蔵サウンドプロセッサ
(7.1ch Sound Processors with Built-in Mode and Input Selectors)

形名 (Type): **BD3471KS2**

パッケージ(Package): SQFP-T80C

機能(Function) :

- Electronic Volume: +32 ~ -95dB / 0.5dB step, Mute
- Mode Selector: LINE(MAIN, SUB), MULTI1, MULTI2, MUte
- Mode Selector: LINE, MULTI1, MULTI2, MUte
- REC Output: 3 stereo output
- MAIN Output: 1 stereo output
- SUB Output: 2 stereo output
- Input Att for ADC: 0, -6, -6.5, -7.5, -9, -12dB, Mute
- Equalizer: SWch, HPF, LPF

○絶対最大定格 (Absolute Maximum Ratings) (Ta=25°C)

項目 (Item)	記号 (Symbol)	定格 (Rating)	単位 (Unit)
正電源電圧(Positive power supply)	Vcc	+7.75 ※1	V
負電源電圧(Negative power supply)	Vee	-7.75 ※1	V
許容損失(Power dissipation)	Pd	1750 ※2	mW
入力電圧範囲 (Input voltage)	Vin	Vee-0.2 ~ Vcc+0.2	V
動作温度範囲(Operating temperature)	Topr	-40 ~ +85	°C
保存温度範囲(Storage temperature)	Tastg	-55 ~ +125	°C

※1: GND を基準として、印加できる最大電圧。(Based on GND, the maximum voltage which can impress.)

※2: Ta>25°Cでは、17.5mW/°Cで軽減。ローム標準基板(サイズ:70mm×70mm×1.6mm)装着時。

(This value decreases 17.5mW/°C for Ta=25°C or more. A standard board, 70×70×1.6 mm, shall be mounted.)

※3: 動作電圧範囲内であれば、動作温度範囲内で一応の回路機能動作が保証されています。

許容損失の条件も温度と関連しますのでご注意ください。

また、この範囲内の電気的特性で定められている条件以外では、その電気的特性の規格値を保証できませんが、本来の機能は維持しています。

(If it within operation voltage range, circuit function operation is guaranteed within operation temp.

It corralled to conditions of power dissipation to temp.

Please watch out except condition stipulated by electrical characteristics within the range, It cannot guarantee standard value of electrical characteristics. But it retains original function.)

○動作条件 (Operating Condition) (Ta=25°C)

項目 (Item)	記号 (Symbol)	範囲 (Range)	単位 (Unit)
正電源電圧(Positive power supply)	Vcc	+6.5 ~ +7.5 ※4	V
負電源電圧(Negative power supply)	Vee	-6.5 ~ -7.5 ※4	V

※4: GND を基準。(Based on GND.)

※5: 動作温度範囲内であれば動作電圧範囲で基本の回路機能動作が保証されていますが、ご使用の際にはよくご確認上、定数と素子の設定、電圧設定、温度設定をお願いします。

また、この範囲内の電気的特性で定められている条件以外では、その電気的特性の規格値を保証できませんが、本来の機能は維持しています。

(Within operation temp range, basic circuit function Operation is guaranteed within operation voltage range.

But please confirm set up of constant and element, voltage set up and temp set up on use.

Please watch out except condition stipulated by electrical characteristics within the range, It cannot guarantee standard value of electrical characteristics. But it retains original function.)

○外形寸法図・標印図 (Outline Dimension): SQFP-T80C (Unit: mm)

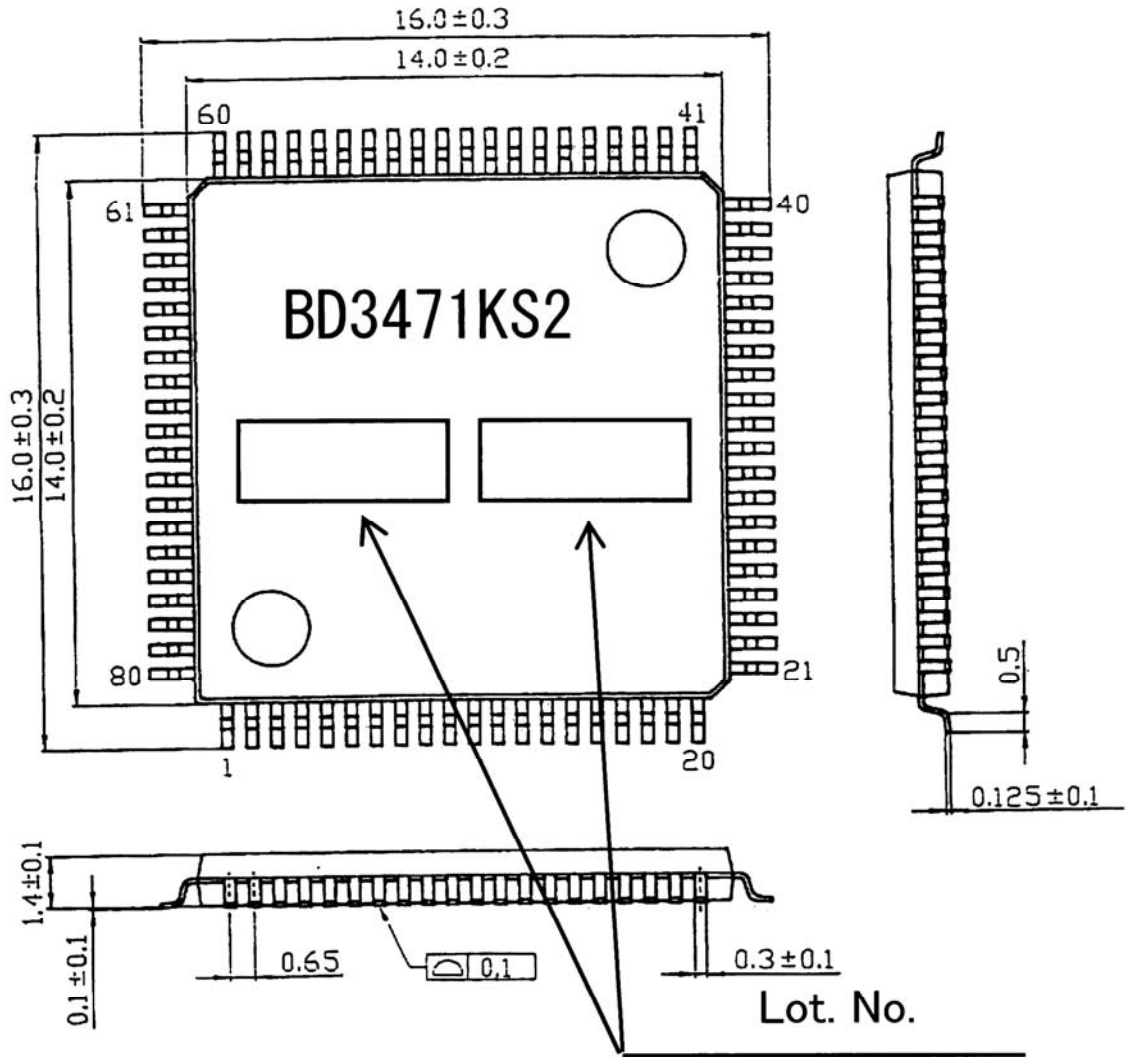

Fig-1 外形寸法図 (Outside dimension)

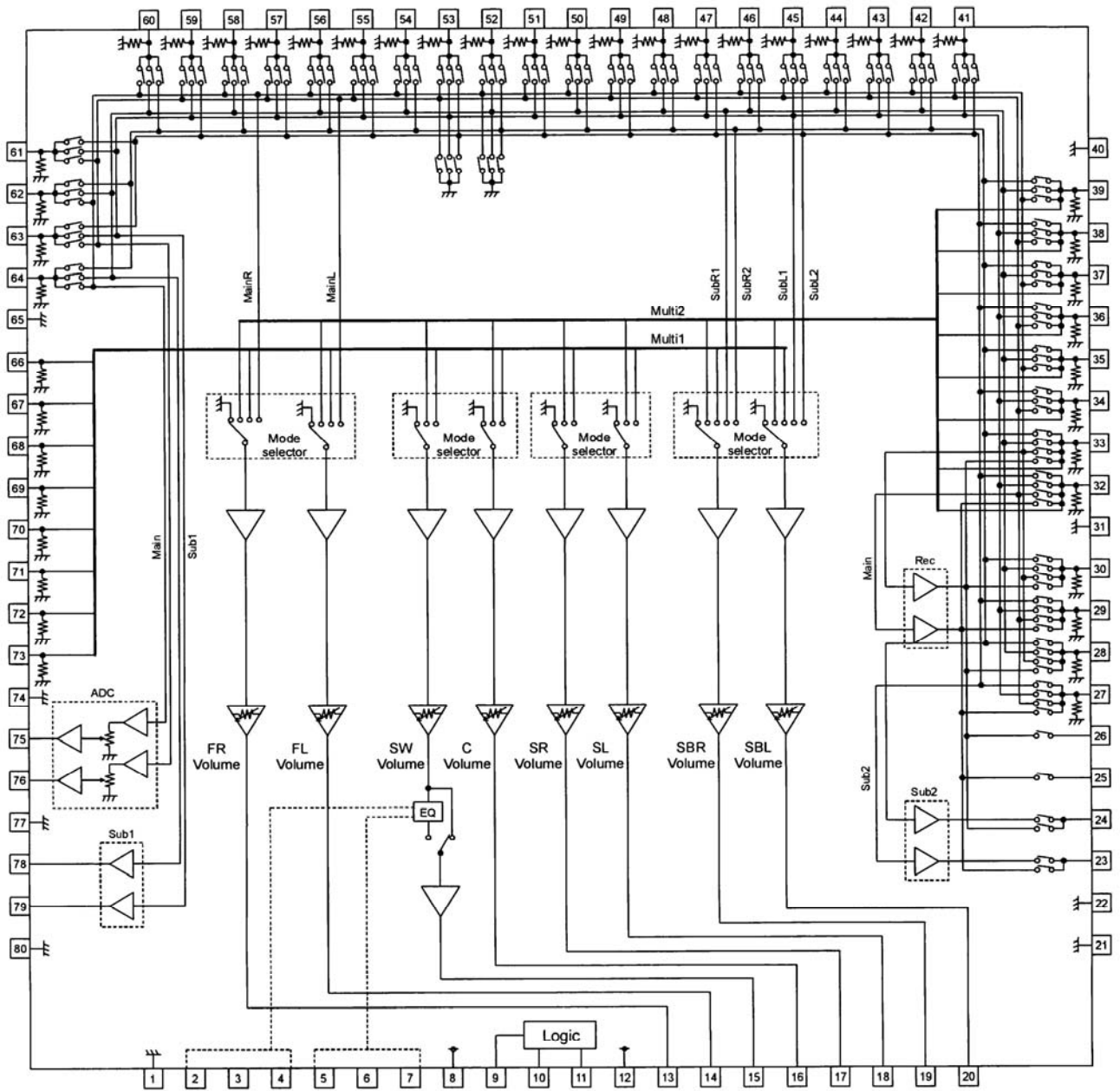

Fig-2 ブロック図 (Block Diagram)

○端子説明 (Description of terminal)

端子番号 (Terminal Number)	端子名 (Terminal Name)	端子説明 (Description of terminal)	端子番号 (Terminal Number)	端子名 (Terminal Name)	端子説明 (Description of terminal)
1	GND	アナロググランド端子 Analog ground terminal	21	GND	アナロググランド端子 Analog ground terminal
2	HPFN	HPFN 端子 HPFN terminal	22	GND	アナロググランド端子 Analog ground terminal
3	LPF01	LPF01 端子 LPF01 terminal	23	SUB2L	Lch SUB2 出力端子 Lch SUB2 output terminal
4	LPF02	LPF02 端子 LPF02 terminal	24	SUB2R	Rch SUB2 出力端子 Rch SUB2 output terminal
5	LPFN2	LPFN2 端子 LPFN2 terminal	25	RECL3	Lch REC 用出力端子 3 Lch REC output terminal 3
6	LPFN1	LPFN1 端子 LPFN1 terminal	26	RECR3	Rch REC 用出力端子 3 Rch REC output terminal 3
7	SWVOL	SWVOL 端子 SWVOL terminal	27	RECL2	Lch REC 用出力端子 2 Lch REC output terminal 2
8	VCC	正電源端子 Positive power supply terminal	28	RECR2	Rch REC 用出力端子 2 Rch REC output terminal 2
9	DGND	デジタルグランド端子 Digital ground terminal	29	RECL1	Lch REC 用出力端子 1 Lch REC output terminal 1
10	DA	データラッチ入力端子 Data and latch input terminal	30	RECR1	Rch REC 用出力端子 1 Rch REC output terminal 1
11	CL	クロック入力端子 Clock input terminal	31	GND	アナロググランド端子 Analog ground terminal
12	VEE	負電源端子 Negative power supply terminal	32	SBLIN2	SBLch DVD 用入力端子 SBLch input terminal for DVD
13	OUTFR	FRch 出力端子 FRch Output terminal	33	SBRIN2	SBRch DVD 用入力端子 SBRch input terminal for DVD
14	OUTFL	FLch 出力端子 FLch Output terminal	34	SLIN2	SLch DVD 用入力端子 SLch input terminal for DVD
15	OUTSW	SWch 出力端子 SWch Output terminal	35	SRIN2	SRch DVD 用入力端子 SRch input terminal for DVD
16	OUTC	Cch 出力端子 Cch Output terminal	36	CIN2	Cch DVD 用入力端子 Cch input terminal for DVD
17	OUTSR	SRch 出力端子 SRch Output terminal	37	SWIN2	SWch DVD 用入力端子 SWch input terminal for DVD
18	OUTSL	SLch 出力端子 SLch Output terminal	38	FLIN2	FLch DVD 用入力端子 FLch input terminal for DVD
19	OUTSBR	SBRch 出力端子 SBRch Output terminal	39	FRIN2	FRch DVD 用入力端子 FRch input terminal for DVD
20	OUTSBL	SBLch 出力端子 SBLch Output terminal	40	GND	アナロググランド端子 Analog ground terminal

○端子説明 (Description of terminal)

端子番号 (Terminal Number)	端子名 (Terminal Name)	端子説明 (Description of terminal)	端子番号 (Terminal Number)	端子名 (Terminal Name)	端子説明 (Description of terminal)
41	INL12	Lch 入力端子 12 Lch input terminal 12	61	INL2	Lch 入力端子 2 Lch input terminal 2
42	INR12	Rch 入力端子 12 Rch input terminal 12	62	INR2	Rch 入力端子 2 Rch input terminal 2
43	INL11	Lch 入力端子 11 Lch input terminal 11	63	INL1	Lch 入力端子 1 Lch input terminal 1
44	INR11	Rch 入力端子 11 Rch input terminal 11	64	INR1	Rch 入力端子 1 Rch input terminal 1
45	INL10	Lch 入力端子 10 Lch input terminal 10	65	GND	アナロググランド端子 Analog ground terminal
46	INR10	Rch 入力端子 10 Rch input terminal 10	66	SBLIN1	SBLch DSP 用入力端子 SBLch input terminal for DSP
47	INL9	Lch 入力端子 9 Lch input terminal 9	67	SBRIN1	SBRch DSP 用入力端子 SBRch input terminal for DSP
48	INR9	Rch 入力端子 9 Rch input terminal 9	68	SLIN1	SLch DSP 用入力端子 SLch input terminal for DSP
49	INL8	Lch 入力端子 8 Lch input terminal 8	69	SRIN1	SRch DSP 用入力端子 SRch input terminal for DSP
50	INR8	Rch 入力端子 8 Rch input terminal 8	70	CIN1	Cch DSP 用入力端子 Cch input terminal for DSP
51	INL7	Lch 入力端子 7 Lch input terminal 7	71	SWIN1	SWch DSP 用入力端子 SWch input terminal for DSP
52	INR7	Rch 入力端子 7 Rch input terminal 7	72	FLIN1	FLch DSP 用入力端子 FLch input terminal for DSP
53	INL6	Lch 入力端子 6 Lch input terminal 6	73	FRIN1	FRch DSP 用入力端子 FRch input terminal for DSP
54	INR6	Rch 入力端子 6 Rch input terminal 6	74	GND	アナロググランド端子 Analog ground terminal
55	INL5	Lch 入力端子 5 Lch input terminal 5	75	ADCR	Rch ADC 用出力端子 Rch output terminal to ADC
56	INR5	Rch 入力端子 5 Rch input terminal 5	76	ADCL	Lch ADC 用出力端子 Lch output terminal to ADC
57	INL4	Lch 入力端子 4 Lch input terminal 4	77	GND	アナロググランド端子 Analog ground terminal
58	INR4	Rch 入力端子 4 Rch input terminal 4	78	SUB1R	Rch SUB1 出力端子 Rch SUB1 Output terminal
59	INL3	Lch 入力端子 3 Lch input terminal 3	79	SUB1L	Lch SUB1 出力端子 Lch SUB1 Output terminal
60	INR3	Rch 入力端子 3 Rch input terminal 3	80	GND	アナロググランド端子 Analog ground terminal

○電気的特性 (Electrical characteristic)

(特に指定のない限り、 $T_a=25^{\circ}\text{C}$ 、 $V_{cc}=7\text{V}$ 、 $V_{ee}=-7\text{V}$ 、 $f=1\text{kHz}$ 、 $V_{in}=1\text{Vrms}$ 、 $R_L=10\text{k}\Omega$ 、
ステレオ入力セレクタ(MAIN, SUB)=IN1、モードセレクタ(FL, FRch)=LINE、モードセレクタ(SW, C, SL, SRch)=MULTI1、
モードセレクタ(SBL, SBRch)=MULTI1、入力アッテネータ=0dB、入力ゲイン=0dB、ボリューム=0dB、イコライザ=OFFとする。)
(Unless specified particularly, $T_a=25^{\circ}\text{C}$ 、 $V_{cc}=7\text{V}$ 、 $V_{ee}=-7\text{V}$ 、 $f=1\text{kHz}$ 、 $V_{in}=1\text{Vrms}$ 、 $R_L=10\text{k}\Omega$ 、
Stereo input selector(MAIN, SUB)=IN1, Mode selector(FL, FRch)=LINE, Mode selector(SW, C, SL, SRch)=MULTI1,
Mode selector(SBL, SBRch)=MULTI1, Input Att=0dB, Input gain=0dB, Volume=0dB, Equalizer=off.)

	記号 (Symbol)	項目 (Parameter)	規格値 (Limit)			単位 (Unit)	測定条件 (Conditions)
			Min.	Typ.	Max.		
TOTAL	Iq	正電源回路電流 Positive circuit current	-	30	60	mA	No signal
		負電源回路電流 Negative circuit current	-60	-30	-		
	Gv	出力電圧利得 Output voltage gain	-1.5	0	1.5	dB	13~20pin output
	CB	チャンネル・バランス Channel balance	-0.5	0	0.5	dB	C Channel reference, 13~20pin output
	THD	全高調波歪率 Total harmonic distortion	-	0.0004	0.02	%	BW=400~30kHz 13~20pin output
	Vom	最大出力電圧 Maximum output voltage	3.8	4.2	-	Vrms	THD=1%, VOLUME=+10dB 13~20pin output
	Vno	出力雑音電圧 Output noise voltage	-	1.5	10	μVrms	$R_g=0\Omega$, BW=IHF-A 13~20pin output
	Vnor	残留雑音電圧 Residual output noise voltage	-	1	8	μVrms	Volume=Mute, $R_g=0\Omega$, BW=IHF-A 13~20pin output
	CT	チャンネル間クロストーク Cross-talk between channels	-	-105	-80	dB	$R_g=0\Omega$, BW=IHF-A 13, 14pin output
	CS	セレクタ間クロストーク Cross-talk between selectors	-	-105	-80	dB	$R_g=0\Omega$, BW=IHF-A 13, 14pin output
	Rin	入力インピーダンス Input impedance	32	47	62	k Ω	27~30, 32~39, 61~64 66~73pin input
VOLUME	ATTmax	最大減衰量 Maximum attenuation	-	-115	-100	dB	Volume=Mute, BW=IHF-A
REC OUT	THDR	全高調波歪率 Total harmonic distortion	-	0.0005	0.02	%	BW=400~30kHz, $R_L=6.8\text{k}\Omega$ 23~30, 32, 33pin output

○制御信号仕様 (Specifications for Control Signal)

(1) 制御信号のタイミング規定 (Timing of control signal)

- ・データはクロック信号の立ち上がりで読み込みます。(Data is read at a rising edge of clock.)
- ・ラッチはクロック信号の立ち下がりでかかり、直前の 16bit のデータが IC 内部に取り込まれます。
(Latch is read at a falling edge of clock. And Data on the latest 16bit are taken in the inside of this IC.)
- ・ラッチ後のクロック、データ信号は LOW で終了して下さい。(Be sure to set DA and CL to LOW after latching.)

1byte=16bit

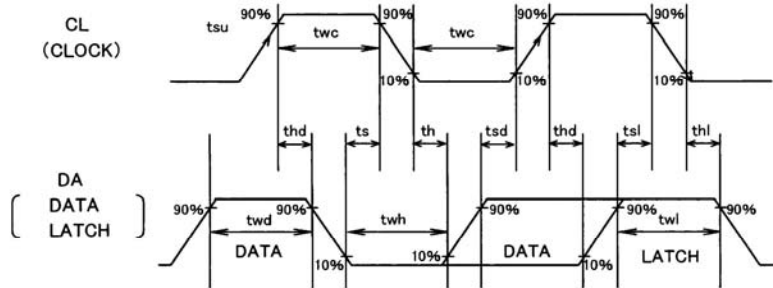

項目 (Parameter)	記号 (Symbol)	規格値 (Limit)			単位 (Unit)
		Min.	Typ.	Max.	
最小クロック幅 (Clock width)	twc	1.0	—	—	μ sec
最小データ幅 (Data width)	twd	1.0	—	—	μ sec
最小ラッチ幅 (Latch width)	twl	1.0	—	—	μ sec
LOW ホールド幅 (Low hold width)	twh	1.0	—	—	μ sec
データ・セットアップ時間 (DATA→CLK) (Data setup time (DATA→CLK))	tsd	0.5	—	—	μ sec
データ・ホールド時間 (CLK→DATA) (Data hold time (CLK→DATA))	thd	0.5	—	—	μ sec
ラッチ・セットアップ時間 (CLK→LATCH) (Latch setup time (CLK→LATCH))	tsl	0.5	—	—	μ sec
ラッチ・ホールド時間 (DATA→LATCH) (Latch hold time)	thl	0.5	—	—	μ sec
ラッチ・ロー・セットアップ時間 (Latch low setup time)	ts	0.5	—	—	μ sec
ラッチ・ロー・ホールド時間 (Latch low hold time)	th	0.5	—	—	μ sec

(2) 制御信号の電圧規定 (Voltage of control signal)

項目 (Parameter)	条件 (Condition)	規格(Limit)			単位 (Unit)
		Min.	Typ.	Max. (≤VCC)	
HIGH 入力電圧 (High input voltage)	Vcc=+6.5~ +7.5V Vee=-6.5~ -7.5V	2.3	—	5.5	V
LOW 入力電圧 (Low input voltage)		0	—	1.0	V

(3) 制御データの基本構成 (Basic Structure of Control Data)

←入力方向 (Input Direction)

D15	D14	D13	D12	D11	D10	D9	D8	D7	D6	D5	D4	D3	D2	D1	D0
Data												Select Address			

(4) 制御データ・テーブル (Table of Control Data)

←入力方向 (Input Direction)

Select Address No.	D15	D14	D13	D12	D11	D10	D9	D8	D7	D6	D5	D4	D3	D2	D1	D0				
0	Input Selector (MAIN)						Rec 1	Rec 2	Rec 3	Rec 4		Rec 5	0	0	0	0				
1	Input Selector (SUB1)						Input selector (SUB2)						0	0	0	1				
2	Mode Select FL, FRch		Mode Select C, SWch		Mode Select SL, SRch		Mode Select SBL, SBRch			ADC ATT			0	0	1	0				
3	Volume channel Select		Volume														0	0	1	1
4	0	SWch EQ	0	0	0	0	0	0	0	0	0	0	1	0	0	0				
5	TEST												1	0	0	1				
6	TEST												1	0	1	0				
7	0	A→B switch-time		0	B→A switch-time		Base clock	0	0	0	0	0	1	0	1	1				
	BD3843FS (6ch Selector IC)												*	1	0	0				
	BD3841FS (9ch Selector IC)												*	1	0	1				
	BD3812F (2ch volume IC)												*	1	1	*				

・同一シリアルラインで、BD3843FS(6ch selector IC)、BD3841FS(9ch selector IC)、BD3812F(2ch volume IC)を制御できます。
(Serial control lines can be shared with BD3843FS(6ch selector IC), BD3841FS(9ch selector IC) and BD3812F(2ch volume IC).)

・電源投入時毎に、全てのデータを初期設定してください。(Initialize all data at every turning on the power supply.)

(例/Example)

←入力方向 Input direction

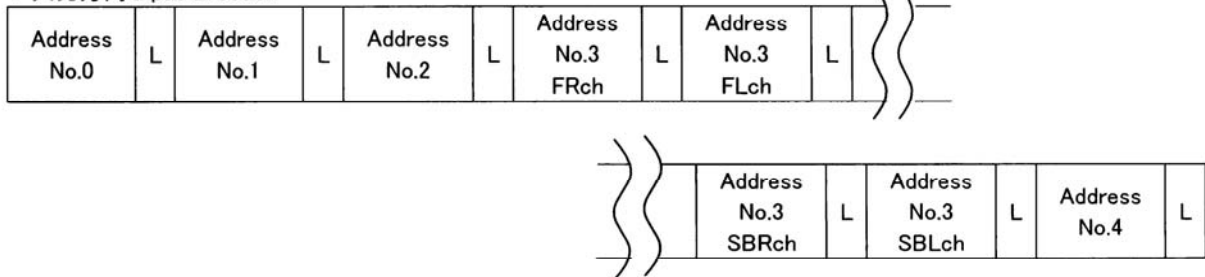

・電源投入後、2回目以降については変更したいデータのみを設定する事が可能です。
(At the second time after turning on the power supply, eight any data to be changed.)

Select Address No.0 設定表 (Select Address No.0 Setting Table)

Function & Setting		D15	D14	D13	D12	D11	D10	D9	D8	D7	D6	D5	D4	D3	D2	D1	D0																									
Input Selector (MAIN)	MUTE	0	0	0	0	0	0	Rec1	Rec2	Rec3	Rec4 / Sub2	Rec5	0	0	0	0	0																									
	IN1	0	0	0	0	0	1																																			
	IN2	0	0	0	0	1	0																																			
	IN3	0	0	0	0	1	1																																			
	IN4	0	0	0	1	0	0																																			
	IN5	0	0	0	1	0	1																																			
	IN6	0	0	0	1	1	0																																			
	IN7	0	0	0	1	1	1																																			
	IN8	0	0	1	0	0	0																																			
	IN9	0	0	1	0	0	1																																			
	IN10	0	0	1	0	1	0																																			
	IN11	0	0	1	0	1	1																																			
	IN12	0	0	1	1	0	0																																			
	IN13	0	0	1	1	0	1																																			
	IN14	0	0	1	1	1	0																																			
	IN15	0	0	1	1	1	1																																			
	IN16	0	1	0	0	0	0																																			
	IN17	0	1	0	0	0	1																																			
	IN18	0	1	0	0	1	0																																			
禁止 (Prohibition)		0	1	0	0	1	1	Rec1	Rec2																																	
	⋮	⋮	⋮	⋮	⋮	⋮	⋮																																			
	1	1	1	1	1	1	1																																			
Rec1	OFF	Input Selector (MAIN)						0	1																																	
	ON							1																																		
Rec2	OFF							Input Selector (MAIN)							0	1																										
	ON														1																											
Rec3	OFF													Input Selector (MAIN)								0	1																			
	ON																					1																				
Rec4 / Sub2	OFF																			Input Selector (MAIN)						Rec1	Rec2	Rec3	0	1												
	ON																												1													
	Rec4																																					0				
	Sub2																																					1				
Rec5	OFF																									Input Selector (MAIN)									Rec4 / Sub2	0	1					
	ON																																			1						

: Initial condition

Select Address No.1 設定表 (Select Address No.1 Setting Table)

Function & Setting		D15	D14	D13	D12	D11	D10	D9	D8	D7	D6	D5	D4	D3	D2	D1	D0
Input Selector (Sub1)	MUTE	0	0	0	0	0	0	Inout Selector (Sub2)						0	0	0	1
	IN1	0	0	0	0	0	1										
	IN2	0	0	0	0	1	0										
	IN3	0	0	0	0	1	1										
	IN4	0	0	0	1	0	0										
	IN5	0	0	0	1	0	1										
	IN6	0	0	0	1	1	0										
	IN7	0	0	0	1	1	1										
	IN8	0	0	1	0	0	0										
	IN9	0	0	1	0	0	1										
	IN10	0	0	1	0	1	0										
	IN11	0	0	1	0	1	1										
	IN12	0	0	1	1	0	0										
	IN13	0	0	1	1	0	1										
	IN14	0	0	1	1	1	0										
	IN15	0	0	1	1	1	1										
	IN16	0	1	0	0	0	0										
	IN17	0	1	0	0	0	1										
	IN18	0	1	0	0	1	0										
禁止 (Prohibition)		0	1	0	0	1	1										
		⋮	⋮	⋮	⋮	⋮	⋮										
		1	1	1	1	1	1										
Input Selector (Sub2)	MUTE	Input selector (Sub1)						0	0	0	0	0	0				
	IN1							0	0	0	0	0	1				
	IN2							0	0	0	0	1	0				
	IN3							0	0	0	0	1	1				
	IN4							0	0	0	1	0	0				
	IN5							0	0	0	1	0	1				
	IN6							0	0	0	1	1	0				
	IN7							0	0	0	1	1	1				
	IN8							0	0	1	0	0	0				
	IN9							0	0	1	0	0	1				
	IN10							0	0	1	0	1	0				
	IN11							0	0	1	0	1	1				
	IN12							0	0	1	1	0	0				
	IN13							0	0	1	1	0	1				
	IN14							0	0	1	1	1	0				
	IN15							0	0	1	1	1	1				
	IN16							0	1	0	0	0	0				
	IN17							0	1	0	0	0	1				
	IN18							0	1	0	0	1	0				
禁止 (Prohibition)								0	1	0	0	1					
								⋮	⋮	⋮	⋮						
								1	1	1	1						

: Initial condition

Select Address No.2 設定表 (Select Address No.2 Setting Table)

Function & Setting		D15	D14	D13	D12	D11	D10	D9	D8	D7	D6	D5	D4	D3	D2	D1	D0			
Mode Selector FL, FRch	MUTE*1	0	0	Mode Selector C, SWch		Mode Selector SL, SRch		Mode Selector SBL, SBRch			ADC ATT			0	0	1	0			
	MAIN	0	1																	
	MULTI1	1	0																	
	MULTI2	1	1																	
Mode Selector C, SWch	MUTE*1	Mode Selector FL, FRch		0	0	Mode Selector C, SWch		Mode Selector SBL, SBRch			ADC ATT			0	0	1	0			
	禁止 (Prohibition)			0	1															
	MULTI1			1	0															
	MULTI2			1	1															
Mode Selector SL, SRch	MUTE*1	Mode Selector FL, FRch		Mode Selector C, SWch		0	0	Mode Selector SBL, SBRch			ADC ATT			0	0	1	0			
	禁止 (Prohibition)					0	1													
	MULTI1					1	0													
	MULTI2					1	1													
Mode Selector SBL, SBRch	MUTE*1	Mode Selector FL, FRch		Mode Selector C, SWch		Mode Selector SL, SRch		0	0	0	ADC ATT			0	0	1	0			
	禁止 (Prohibition)							0	0	1										
	MULTI1							0	1	0										
	MULTI2							0	1	1										
	Sub1(L, R)							1	0	0										
	Sub2(L, R)							1	0	1										
	禁止 (Prohibition)							1	1	0										
	禁止 (Prohibition)							1	1	1										
ADC ATT	MUTE*1	Mode Selector FL, FRch		Mode Selector C, SWch		Mode Selector SL, SRch		Mode Selector SBL, SBRch			0	0	0	ADC ATT			0	0	1	0
	0dB										0	0	1							
	-6dB										0	1	0							
	-6.5dB										0	1	1							
	-7.5dB										1	0	0							
	-9dB										1	0	1							
	-12dB										1	1	0							
	禁止 (Prohibition)										1	1	1							

: Initial condition

※1. 全ての出力に高速 MUTE をかけたい場合、Mode Selector にて MUTE を設定してください
ただし、この設定方法の場合、データ送信後に POP ノイズが発生します
(When wanting to set high-speed MUTE on all output, set MUTE in Mode Selector.
In case of this way of setting, the POP noise occurs after data transmission.)

Select Address No.3 設定表 (Select Address No.3 Setting Table)

Function & Setting		D15	D14	D13	D12	D11	D10	D9	D8	D7	D6	D5	D4	D3	D2	D1	D0	
Volume channel Select	FR	0	0	0	Volume													
	FL	0	0	1														
	SW	0	1	0														
	C	0	1	1														
	SR	1	0	0														
	SL	1	0	1														
	SBR	1	1	0														
	SBL	1	1	1														
Volume	MUTE	Volume Channel Select			1	1	1	1	1	1	1	1	1	0	0	1	1	
	禁止 (Prohibition)					1	1	1	1	1	1	1	0					
	⋮					⋮	⋮	⋮	⋮	⋮	⋮	⋮	⋮					
	+32.0dB					0	1	0	0	0	0	0	0					1
	+31.5dB					0	1	0	0	0	0	0	0					0
	+31.0dB					0	0	1	1	1	1	1	1					1
	⋮					⋮	⋮	⋮	⋮	⋮	⋮	⋮	⋮					⋮
	+1.0dB					0	0	0	0	0	0	0	1					0
	+0.5dB					0	0	0	0	0	0	0	0					1
	禁止 (Prohibition)					0	0	0	0	0	0	0	0					0
	0dB					0	0	0	0	0	0	0	0					0
	-0.5dB					0	0	0	0	0	0	0	0					1
	⋮					⋮	⋮	⋮	⋮	⋮	⋮	⋮	⋮					⋮
	-31.0dB					0	0	1	1	1	1	1	1					0
	-31.5dB					0	0	1	1	1	1	1	1					1
	-32.0dB					0	1	0	0	0	0	0	0					0
	⋮				⋮	⋮	⋮	⋮	⋮	⋮	⋮	⋮	⋮					
	-63.0dB				0	1	1	1	1	1	1	1	0					
	-63.5dB				0	1	1	1	1	1	1	1	1					
	-64.0dB				1	0	0	0	0	0	0	0	0					
	⋮				⋮	⋮	⋮	⋮	⋮	⋮	⋮	⋮	⋮					
	-79.0dB				1	0	0	1	1	1	1	1	0					
	-79.5dB				1	0	0	1	1	1	1	1	1					
	-80.0dB				1	0	1	0	0	0	0	0	0					
	⋮				⋮	⋮	⋮	⋮	⋮	⋮	⋮	⋮	⋮					
	-94.0dB				1	0	1	1	1	1	1	0	0					
	-94.5dB				1	0	1	1	1	1	1	0	1					
	-95.0dB				1	0	1	1	1	1	1	1	0					
	禁止 (Prohibition)				1	0	1	1	1	1	1	1	1					
	⋮				⋮	⋮	⋮	⋮	⋮	⋮	⋮	⋮	⋮					
	⋮				1	1	1	1	1	1	1	1	1					

: Initial condition

Select Address No.4 設定表 (Select Address No.4 Setting Table)

Function & Setting		D15	D14	D13	D12	D11	D10	D9	D8	D7	D6	D5	D4	D3	D2	D1	D0
SWch EQ	PASS	0	0	0	0	0	0	0	0	0	0	0	0	1	0	0	0
	SWch EQ ON		1														

: Initial condition

Select Address No.7 設定表 (Select Address No.7 Setting Table)

Function & Setting		D15	D14	D13	D12	D11	D10	D9	D8	D7	D6	D5	D4	D3	D2	D1	D0
A→B switching-time	11msec	0	0	0	0	B→A switching-time	Base clock	0	0	0	0	0	0	1	0	1	1
	5msec		0	1													
	7msec		1	0													
	15msec		1	1													

Select Address No.7 設定表 (Select Address No.7 Setting Table)

Function & Setting		D15	D14	D13	D12	D11	D10	D9	D8	D7	D6	D5	D4	D3	D2	D1	D0
B→A switching-time	11msec	0	A→B switching-time	0	0	0	0	Base clock	0	0	0	0	0	1	0	1	1
	5msec					0	1										
	7msec					1	0										
	15msec					1	1										

Select Address No.7 設定表 (Select Address No.7 Setting Table)

Function & Setting		D15	D14	D13	D12	D11	D10	D9	D8	D7	D6	D5	D4	D3	D2	D1	D0
Base clock	× 1	0	A→B switching-time	0	B→A switching-time	0	0	0	0	0	0	0	0	1	0	1	1
	× 1/2					1											

○端子等価回路および説明 (Terminal Equivalent Circuit and Description)

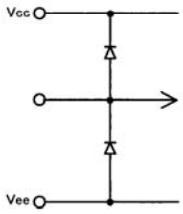
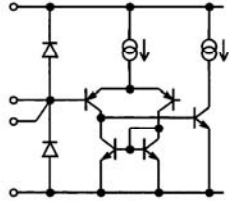
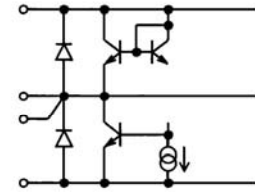
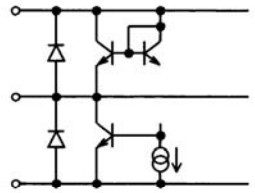
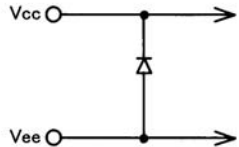
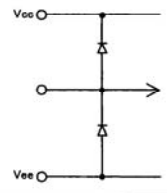
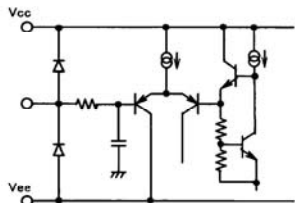
端子番号 Terminal No.	端子名 Terminal Name	端子電圧 Terminal Voltage	等価回路 Equivalent Circuit	端子説明 Terminal Description
1 21 22 31 40 65 74 77 80	AGND	0		アナロググランド端子です。 Analog ground terminals.
2 5 6	HPFN LPFN2 LPFN1	0		LPF 用 amp, HPF 用 amp 入力端子です。 Input terminals for LPF amp and HPF amp.
3 4	LPF02 LPF01	0		LPF 用 amp 出力端子です。 Output terminals for LPF amp.
7	SWVOL	0		SWch ポリウムアンプ出力用端子です。 Output terminal for SWch Volume amp.
8 12	VCC VEE	-7 +7		正電源端子、負電源端子です。 Positive power supply terminal and Negative power supply terminal.
9	DGND	0		デジタルグランド端子です。 Digital ground terminal.
10 11	DA CL	—		クロック、データ入力端子です。 Input terminals for a clock and data.

端子番号 Terminal No.	端子名 Terminal Name	端子電圧 Terminal Voltage	等価回路 Equivalent Circuit	端子説明 Terminal Description
13 14 15 16 17 18 19 20	OUTFR OUTFL OUTSW OUTC OUTSR OUTSL OUTSBR OUTSBL	0		アナログマルチ音声信号出力用端子です。 Output terminals for analog multi sound signal.
23 24	RECL4 (SUB2L) RECR4 (SUB2R)	0		REC 用、サブ用ステレオ音声信号出力端子です。 Output terminals for recording stereo sound signal, SUB..
25 26	RECL3 RECR3	0		REC 用ステレオ音声信号出力端子です。 Output terminals for recording stereo sound signal.
27 28 29 30	RECL2 (INL18) RECR2 (INR18) RECL1 (INL17) RECR1 (INR17)	0		ステレオ音声信号入力、 REC 用ステレオ音声信号出力端子です。 REC OFF 時の入力インピーダンスは 47kΩ (Typ.)です。 Input terminal for a stereo sound signal. And output terminal for recording stereo sound signal. Input impedance is 47kΩ (Typ.) when setting REC OFF.

端子番号 Terminal No.	端子名 Terminal Name	端子電圧 Terminal Voltage	等価回路 Equivalent Circuit	端子説明 Terminal Description
32	SBLIN2 (INL16) (RECL5)	0		<p>アナログマルチ2音声信号入力、ステレオ音声信号入力、REC用ステレオ音声信号出力端子です。REC OFF時の入力インピーダンスは47kΩ(Typ.)です。</p> <p>Input terminal for an analog multi2 sound signal and a stereo sound signal. And output terminal for recording stereo sound signal.</p> <p>Input impedance is 47kΩ(Typ.) when setting REC OFF.</p>
33	SBRIN2 (INR16) (RECR5)			
34	SLIN2 (INL15)	0		<p>アナログマルチ2音声信号入力、ステレオ音声信号入力用端子です。入力インピーダンスは、47kΩ(Typ.)です。</p> <p>Input terminal for an analog multi2 sound signal and a stereo sound signal. Input impedance is 47kΩ(Typ.).</p>
35	SRIN2 (INR15)			
36	CIN2 (INR14)			
37	SWIN2 (INL14)			
38	FLIN2 (INL13)			
39	FRIN2 (INR13)			
41	INL12	0		<p>ステレオ音声信号入力用端子です。入力インピーダンスは、47kΩ(Typ.)です。</p> <p>Input terminals for stereo sound signal. Input impedance is 47kΩ(Typ.).</p>
42	INR12			
43	INL11			
44	INR11			
45	INL10			
46	INR10			
47	INL9			
48	INR9			
49	INL8			
50	INR8			
51	INL7			
52	INR7			
53	INL6			
54	INR6			
55	INL5			
56	INR5			
57	INL4			
58	INR4			
59	INL3			
60	INR3			
61	INL2			
62	INR2			
63	INL1			
64	INR1			

端子番号 Terminal No.	端子名 Terminal Name	端子電圧 Terminal Voltage	等価回路 Equivalent Circuit	端子説明 Terminal Description
66 67 68 69 70 71 72 73	SBLIN1 SBRIN1 SLIN1 SRIN1 CIN1 SWIN1 FLIN1 FRIN1	0		<p>アナログマルチ1音声信号入力用端子です。 入力インピーダンスは、47kΩ(Typ.)です。 Input terminals for an analog multi1 sound signal. Input impedance is 47kΩ(Typ.).</p>
75 76 78 79	ADCR ADCL SUB1R SUB1L	0		<p>ADC用、サブ用のステレオ音声出力端子です。 Stereo sound signal output terminals for ADC, SUB.</p>

○応用回路図 (Application Circuit Diagram)

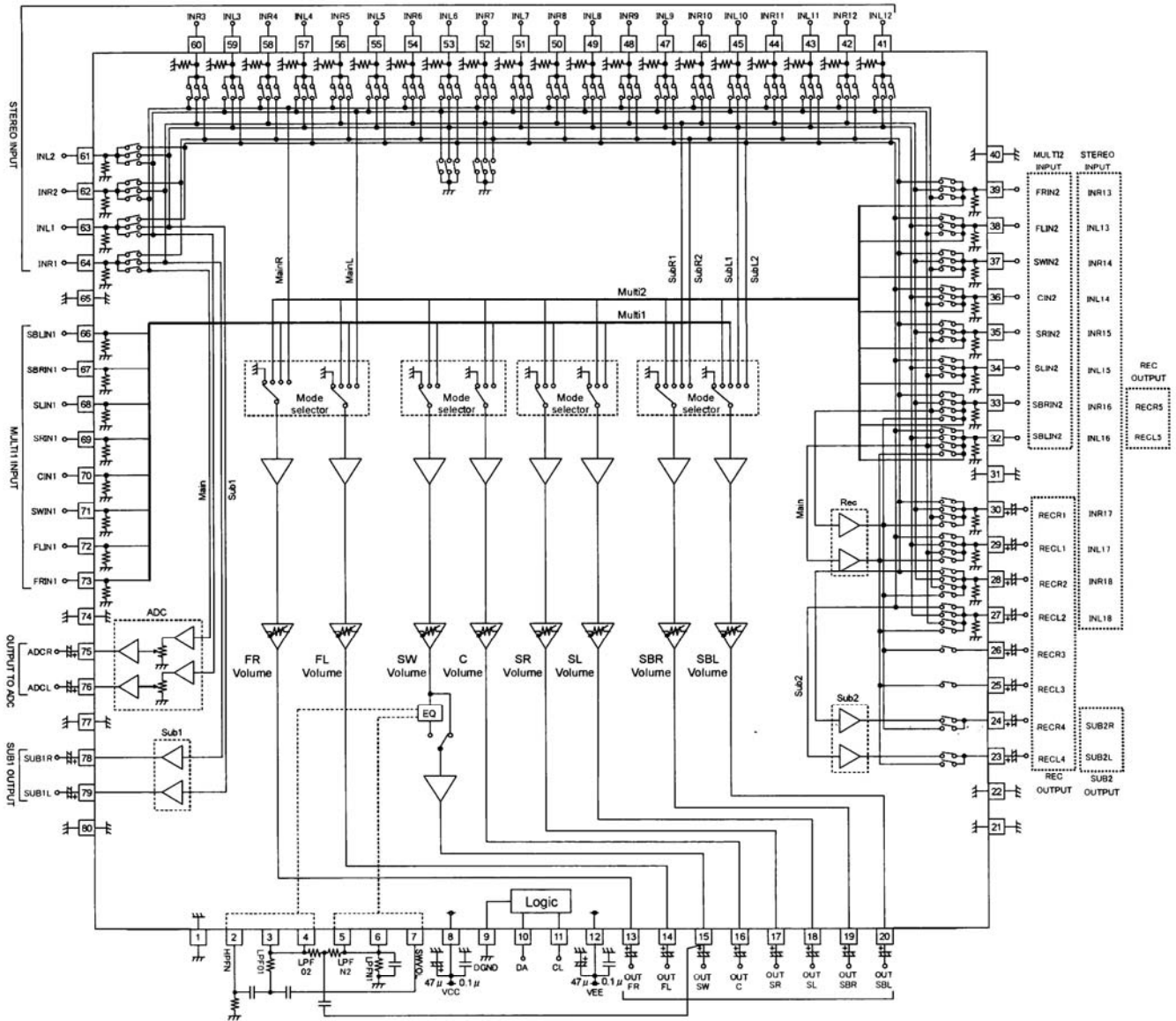

配線上の注意

- ① GND は太く基準GNDから取って下さい。
- ② CL、DA の配線パターンはアナログ部の配線パターンから離して、クロストークしないようにして下さい。
- ③ CL、DA の配線パターンは、なるべく平行に引かないで下さい。隣接する時はシールドするようにして下さい。
- ④ 入力セレクタの入力端子の配線パターンはクロストークに注意して下さい。配線間をシールドすることを推奨致します。
- ⑤ 電源のデカップリングコンデンサは、VCC、GND、VEE に対して、出来るだけ最短距離で接続してください。

Notes on wiring

- ① GND shall be wired from reference point and thicken.
- ② Wiring pattern of CL and DA shall be away from that of analog unit and cross-talk shall not be acceptable.
- ③ Lines of CL and DA of shall not be parallel if possible. The lines shall be shielded, if they are adjacent to each other.
- ④ Please pay attention the wiring pattern of the input terminal of the input selector to the cross talk. Recommend that wiring period is shielded.
- ⑤ Please connect the decoupling capacitor of a power supply in the shortest distance as much as possible to VCC and GND, VEE.

○イコライザ・フィルタの定数設定 (Constant set-up of equalizer filter)

Select Address No.4 D14:1

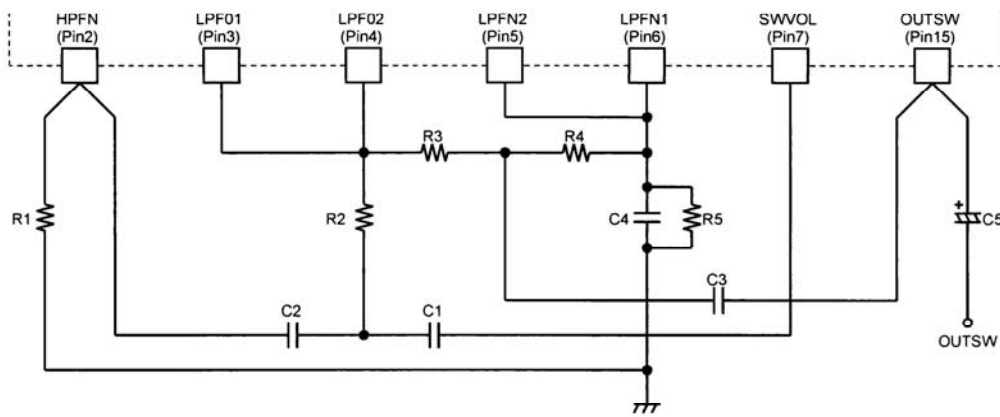
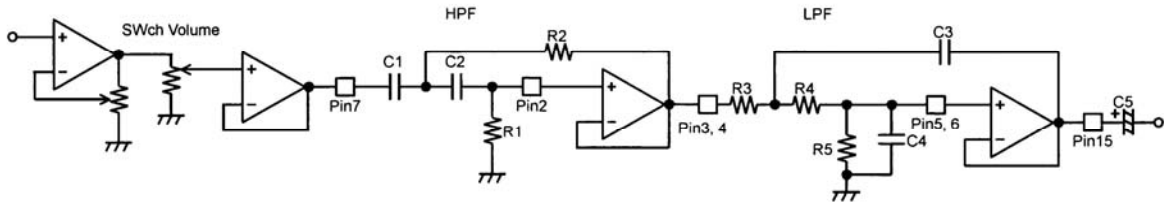

○HPF の計算式 (Equation of HPF)
カットオフ周波数 Cutoff Frequency

$$f_c = \frac{1}{2\pi\sqrt{C_1 C_2 R_1 R_2}} [\text{Hz}] \quad Q = \frac{\sqrt{C_1 C_2 R_1 R_2}}{R_2 C_1 + R_2 C_2}$$

○LPF の計算式 (Equation of LPF)
カットオフ周波数 Cutoff Frequency

$$f_c = \frac{1}{2\pi} \sqrt{\frac{R_3 + R_4 + R_5}{C_3 C_4 R_3 R_4 R_5}} [\text{Hz}] \quad Q = \frac{\sqrt{(R_3 + R_4 + R_5)(C_3 C_4 R_3 R_4 R_5)}}{C_3 R_3 R_4 + C_4 R_3 R_5 + C_4 R_4 R_5}$$

ゲイン LPF Gain

$$G_v = 20 \log \left(\frac{R_5}{R_3 + R_4 + R_5} \right) [\text{dB}]$$

○イコライザ・フィルタを使用しない場合 (When don't use an equalizer filter)

Select Address No.4 D14:0

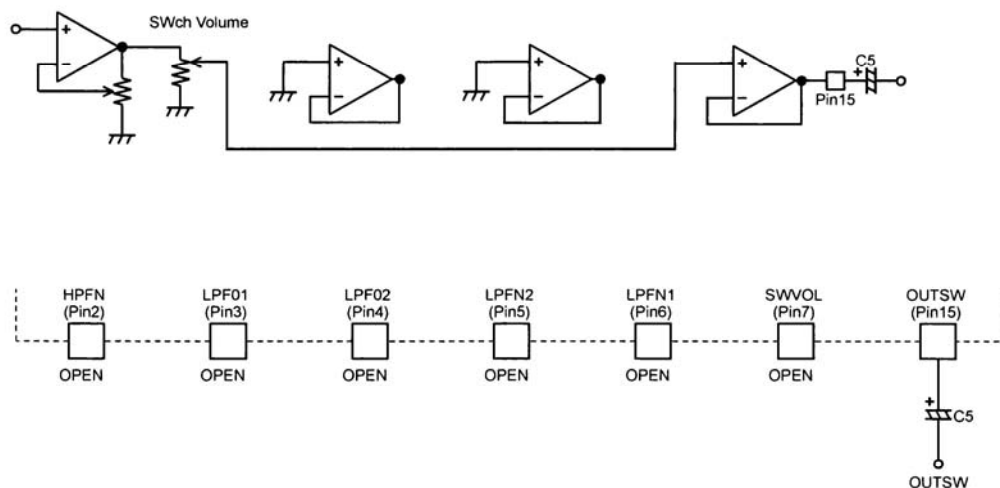

○データ送信上の注意点 (Caution on send data)

ゲイン切替時の内部処理時間 A→B/ B→A の動作中にデータ送信をした場合、以下のように動作します。
When send the data among the switching process, internal operation is as below.

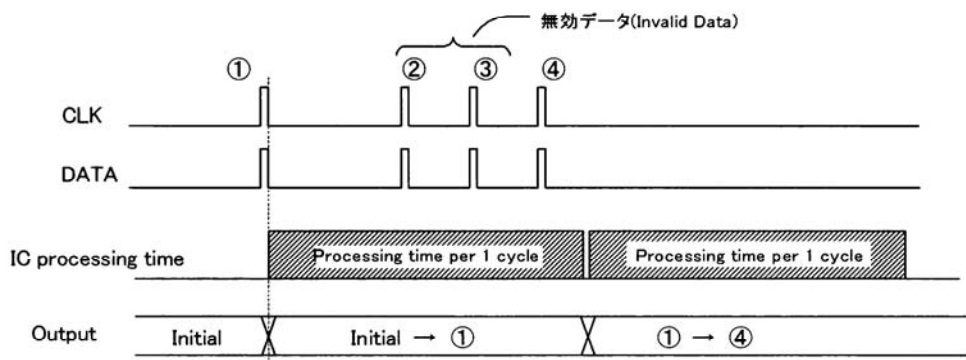

②、③のデータは無効となり、④が有効となります。また送信タイミング上の規定はありません。
When send the data above timing, only ④ is active. And, there is a NOT regulation on send timing.

○ゲイン切替時ショックノイズ (About pop noise in gain changing)

上記内部処理状態 A および B の出力 DC オフセットの差によってショックノイズのレベルが異なる事があります。
The level of the pop noise sometimes varies in the difference in output DC offset of the inside condition A and B.

○使用上の注意 (Note on use)

(1)絶対最大定格について (Absolute maximum ratings)

印加電圧及び動作温度範囲などの絶対最大定格を超えた場合は、LSI が破壊することがあります。絶対最大定格を超える電圧及び温度を印加しないでください。絶対最大定格を超えるような事が考えられる場合には、ヒューズなどの物理的な安全対策を実施して頂き、LSI に絶対最大定格を超える条件が印加されないようご検討ください。

If applied voltage, operating temperature range, or other absolute maximum ratings are exceeded, the LSI may be damaged. Do not apply voltages or temperatures that exceed the absolute maximum ratings. If you think of a case in which absolute maximum ratings are exceeded, enforce fuses or other physical safety measures and investigate how not to apply the conditions under which absolute maximum ratings are exceeded to the LSI.

(2)Vee 電位について (Vee potential)

Vee 端子の電圧はいかなる動作状態においても、最低電圧になるようにしてください。過渡現象を含めて、各端子電圧が Vee 端子よりも低い電圧になっていないことを実際にご確認下さい。

Make the Vee pin voltage such that it is the lowest voltage even when operating below it. Actually confirm that the voltage of each pin does not become a lower voltage than the Vee pin, including transient phenomena.

(3)熱設計について (Thermal design)

実使用状態での許容損失を考慮して、十分なマージンを持った熱設計を行ってください。

Perform thermal design in which there are adequate margins by taking into account the allowable power dissipation in actual states of use.

(4)端子間ショートと誤実装について (Shorts between pins and misinstallation)

LSI を基板に実装する時には、LSI の方向や位置ずれに十分注意してください。誤って実装し通電した場合、LSI を破壊することがあります。また、LSI の端子間や端子と電源間、端子と GND 間に異物が入るなどしてショートした場合についても破壊することがあります。

When mounting the LSI on a board, pay adequate attention to orientation and placement discrepancies of the LSI. If it is misinstalled and the power is turned on, the LSI may be damaged. It also may be damaged if it is shorted by a foreign substance coming between pins of the LSI or between a pin and a power supply or a pin and a GND.

(5)強電磁界内での動作について (Operation in strong magnetic fields)

強電磁界内での使用は、誤動作をする可能性がありますので十分ご評価ください。

Adequately evaluate use in a strong magnetic field, since there is a possibility of malfunction.

(6)動作電圧範囲及び動作温度範囲について (About Operating Voltage Range and Operating Temperature Range)

回路機能動作に対しては、動作電圧範囲及び動作温度範囲内で保証しています。ただし、電気的特性の規格値はその電気的特性の規定条件での保証となります。したがって、IC の特性変動を十分考慮のうえ、セット設計をしてください。

The circuit functional operations are guaranteed within the Operating Voltage Range and Operating Temperature Range. The standard values of electrical characteristics, however, are guaranteed under the specific conditions. Accordingly, careful consideration of the IC characteristic variations is required to design a set of circuit.

(7)電源 ON/OFF 時について (About power ON/OFF)

①電源 ON/OFF 時はショック音が発生しますので、セット上にて MUTE をかけてください。

At power ON/OFF, a shock sound will be generated and, therefore, use MUTE on the set.

②電源の立ち上げ時は、VEE と VCC を同時に立ち上げるか、VEE 側を早く立ち上げてください。

VCC 側を先に立ち上げますと VCC-VEE 間に過大な電流が流れます。

When turning on power supplies, VEE and VCC should be powered on simultaneously or VEE first; then followed by VCC. If the VCC side is started up first, an excessive current may pass VCC through VEE.

(8)シリアルコントロールについて (About serial control)

CL 端子、DA 端子はアナログ信号系のラインへ干渉しないように配線及びパターン配線してください。

For the CL and DA terminals, the patterned and other wirings should be routed not to cause interference with the analog-signal-related lines.

(9)ファンクション切り替えについて (About function switching)

入力セクタ、モードセクタ、入力ゲイン等を切り替える時はボリュームにて MUTE をかけてください。

When switching Input Selector, Mode selector or Input Gain, use MUTE on Volume.

Notes

No copying or reproduction of this document, in part or in whole, is permitted without the consent of ROHM Co.,Ltd.

The content specified herein is subject to change for improvement without notice.

The content specified herein is for the purpose of introducing ROHM's products (hereinafter "Products"). If you wish to use any such Product, please be sure to refer to the specifications, which can be obtained from ROHM upon request.

Examples of application circuits, circuit constants and any other information contained herein illustrate the standard usage and operations of the Products. The peripheral conditions must be taken into account when designing circuits for mass production.

Great care was taken in ensuring the accuracy of the information specified in this document. However, should you incur any damage arising from any inaccuracy or misprint of such information, ROHM shall bear no responsibility for such damage.

The technical information specified herein is intended only to show the typical functions of and examples of application circuits for the Products. ROHM does not grant you, explicitly or implicitly, any license to use or exercise intellectual property or other rights held by ROHM and other parties. ROHM shall bear no responsibility whatsoever for any dispute arising from the use of such technical information.

The Products specified in this document are intended to be used with general-use electronic equipment or devices (such as audio visual equipment, office-automation equipment, communication devices, electronic appliances and amusement devices).

The Products specified in this document are not designed to be radiation tolerant.

While ROHM always makes efforts to enhance the quality and reliability of its Products, a Product may fail or malfunction for a variety of reasons.

Please be sure to implement in your equipment using the Products safety measures to guard against the possibility of physical injury, fire or any other damage caused in the event of the failure of any Product, such as derating, redundancy, fire control and fail-safe designs. ROHM shall bear no responsibility whatsoever for your use of any Product outside of the prescribed scope or not in accordance with the instruction manual.

The Products are not designed or manufactured to be used with any equipment, device or system which requires an extremely high level of reliability the failure or malfunction of which may result in a direct threat to human life or create a risk of human injury (such as a medical instrument, transportation equipment, aerospace machinery, nuclear-reactor controller, fuel-controller or other safety device). ROHM shall bear no responsibility in any way for use of any of the Products for the above special purposes. If a Product is intended to be used for any such special purpose, please contact a ROHM sales representative before purchasing.

If you intend to export or ship overseas any Product or technology specified herein that may be controlled under the Foreign Exchange and the Foreign Trade Law, you will be required to obtain a license or permit under the Law.



Thank you for your accessing to ROHM product informations.
More detail product informations and catalogs are available, please contact us.

ROHM Customer Support System

<http://www.rohm.com/contact/>