500mA Dual Linear Regulator with V_{AUX} Driver

FEATURES

- Continuous 3.3V output from three inputs
- Complete power management solution
- V_{CC} , V_{SBY} regulator supplies 500mA output
- Built-in hysteresis when selecting input supplies
- Drive control signal for external V_{AUX} switch
- Output can be forced higher than input (off-state)

APPLICATIONS

- Desktop Computers
- PCI Adapter Cards with Wake-on-LAN
- Network Interface Cards (NICs)
- Multi-power Systems
- Systems with Standby Capabilities

DESCRIPTION

The SS6532 is a dual-input regulator with V_{AUX} drive control capable of delivering 3.3V/500mA continuously. The output power is provided from three independent input voltage sources on a prioritized basis. Power is always taken in priority using the following order: V_{CC} , V_{SBY} , and V_{AUX} .

The SS6532 meets Intel's "Instantly Available" power requirements which follow the ACPI "Advanced Configuration and Power Interface" standards.

When either V_{CC} or V_{SBY} is present, the device automatically enables the regulator and produces a stable 3.3V output. When only V_{AUX} (3.3V) is present, the drive control output will turn on an external P-MOSFET switch from an auxiliary 3.3V supply V_{AUX} to maintain V_{OUT} .

The IC also prevents excessive current from flowing back from V_{OUT} to either input or ground when the output voltage is greater than the input voltage.

All the control circuitry needed to provide a smooth and automatic transition between all three supplies has been incorporated. This allows both V_{CC} and V_{SBY} to be dynamically switched without loss of output voltage.

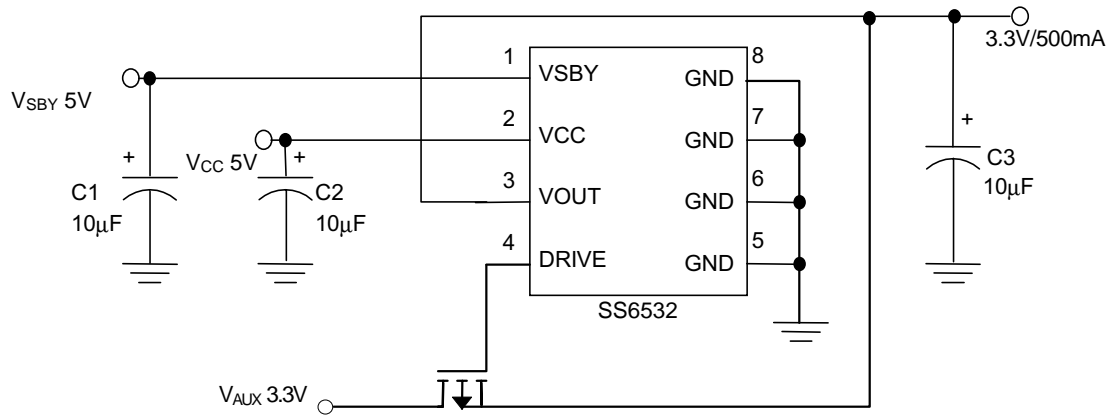
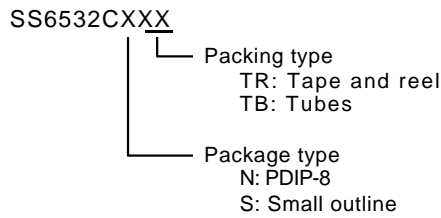
TYPICAL APPLICATION CIRCUIT

Dual-input Regulator with Auxiliary Driver
ORDERING INFORMATION

Example: SS6532CSTR

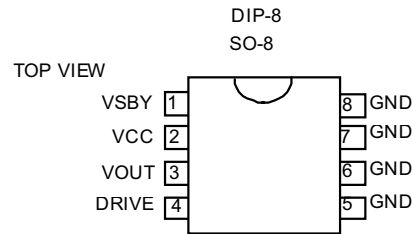
→ in SO-8 package on tape and reel.
(CN/PDIP-8 is only available in tubes)

PIN CONFIGURATION

ABSOLUTE MAXIMUM RATINGS

V_{CC} , V_{SBY} Input Voltage	7.0V
V_{AUX} Input Voltage	4.0V
V_{OUT} Output Voltage	5.0V
Operating Temperature Range	-40°C~85°C
Storage Temperature Range	-65°C ~ 150°C

ELECTRICAL CHARACTERISTICS ($V_{IN}=5V$, $T_A=25^{\circ}C$, unless otherwise specified)

PARAMETERS	CONDITIONS	MIN.	TYP.	MAX.	UNITS
Regulated Output Voltage	$0mA < I_{LOAD} < 500mA$	3.135	3.300	3.465	V
Regulated Output Current		500			mA
Output Voltage Load Regulation	V_{CC} selected $I_{LOAD}=50mA \sim 500mA$ V_{SBY} selected $I_{LOAD}=50mA \sim 500mA$		20		mV
Output Voltage Line Regulation	$V_{CC}=4.5V \sim 5.5V$, $I_{LOAD}=5mA$ $V_{SBY}=4.5V \sim 5.5V$, $I_{LOAD}=5mA$		2		mV
VCC Select Voltage	$V_{SBY} > V_{SBYDES}$ or V_{AUX} present		4.50	4.60	V
VCC Deselect Voltage	$V_{CC} < V_{CCDES}$	3.90	4.20		V
V_{SBY} Select Voltage	V_{AUX} present		4.50	4.60	V
V_{SBY} Deselect Voltage	$V_{SBY} < V_{SBYDES}$	3.90	4.20		V
Hysteresis Voltage			0.30		V
Short Circuit Current	$V_{CC}/SBY=5V$, $V_{OUT}=0V$		1000		mA
V_{CC} Pin Reverse Leakage	$V_{CC} = 0V$, $V_{SBY} = 5V$		5	50	μA
V_{SBY} Pin Reverse Leakage	$V_{CC} = 5V$, $V_{SBY} = 0V$		5	50	μA
Ground Current	$V_{CC}/SBY=5V$, $I_{LOAD} = 0mA$ $V_{CC}/SBY=5V$, $I_{LOAD} = 500mA$		100	500	μA
Short Circuit Current	$V_{CC}/SBY=5V$, $V_{OUT}=0V$		1000		mA
V_{DRIVE} High Voltage	V_{CC} or V_{SBY} selected	3.75	4.00		V
Drive delay	Drive High Delay Drive Low Delay		5.0 0.5		μs
Drive Pin Current limit	$V_{DRIVE}=1V$, $V_{CC}=5V$	0.5	6.0	25.0	mA

TYPICAL PERFORMANCE CHARACTERISTICS

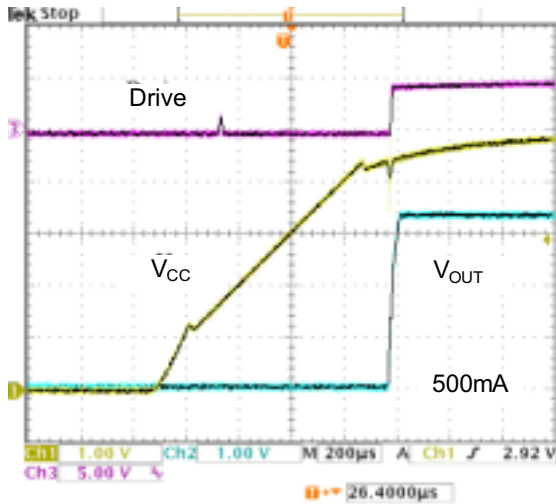

Fig. 1 V_{CC} Cold Start

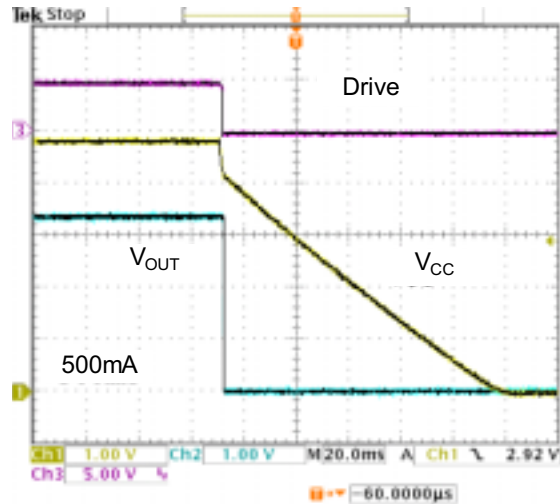

Fig. 2 V_{CC} Full Power Down

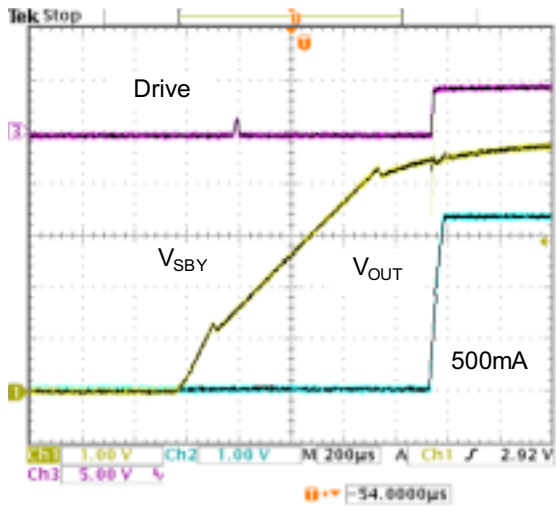

Fig. 3 V_{SBY} Cold Start

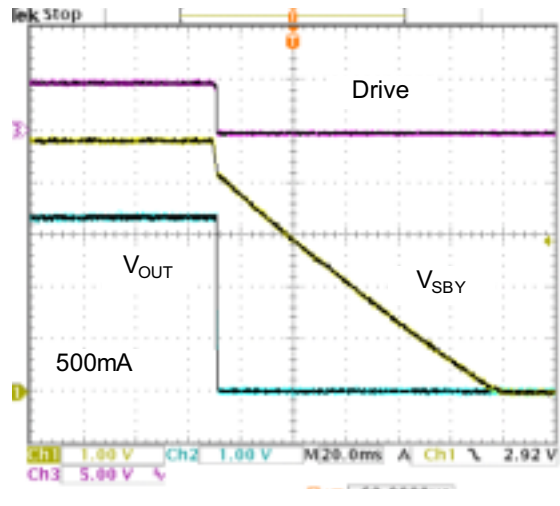

Fig. 4 V_{SBY} full power down

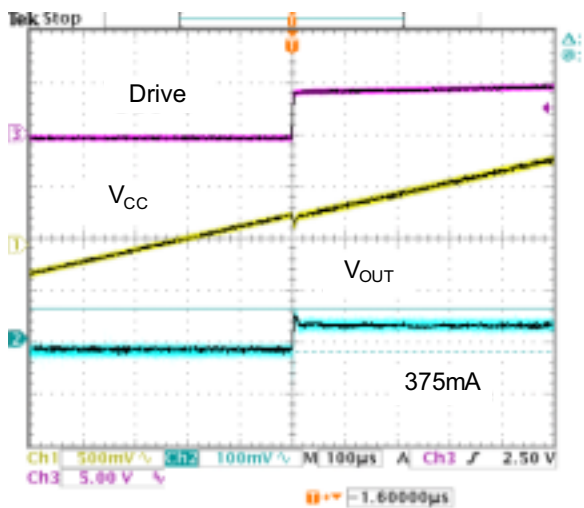

Fig. 5 V_{CC} Power-Up

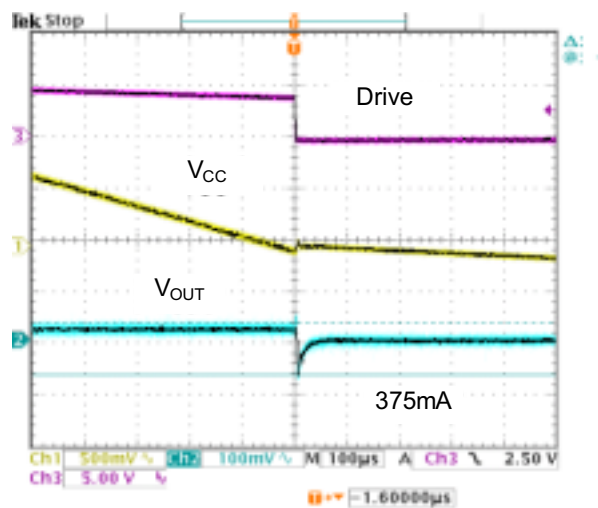

Fig. 6 V_{CC} power-down

TYPICAL PERFORMANCE CHARACTERISTICS (contd.)

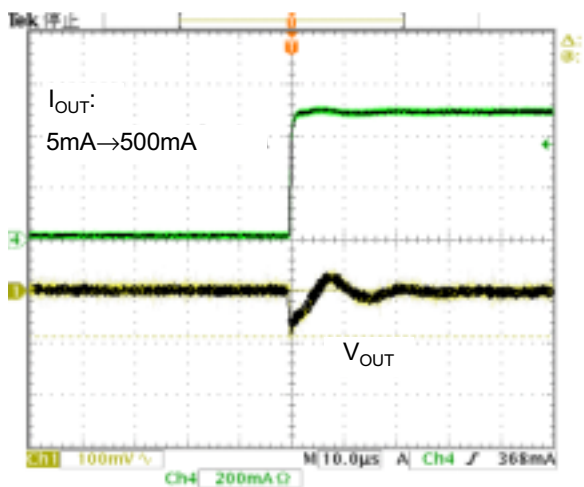

Fig. 7 V_{CC} Load Transient Rising

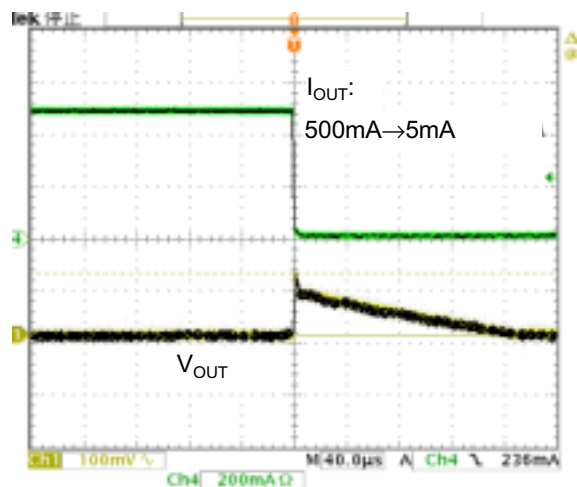

Fig. 8 V_{CC} Load Transient Falling

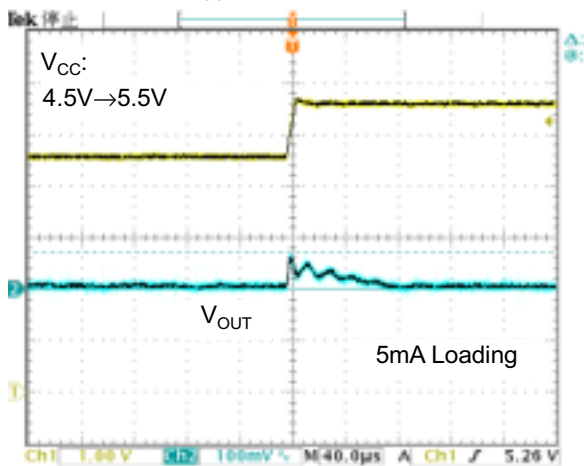

Fig. 9 V_{CC} Line Transient Rising

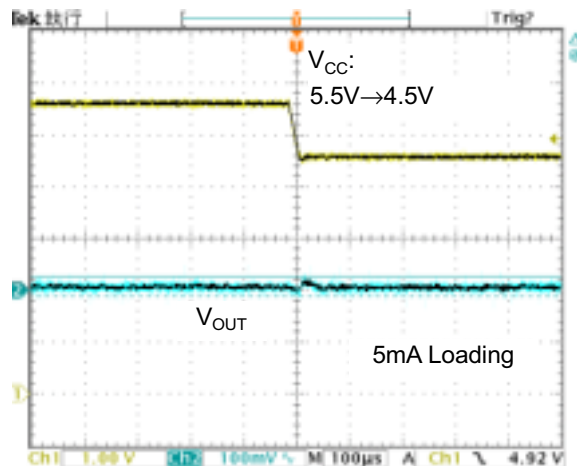

Fig. 10 V_{CC} Line Transient Falling

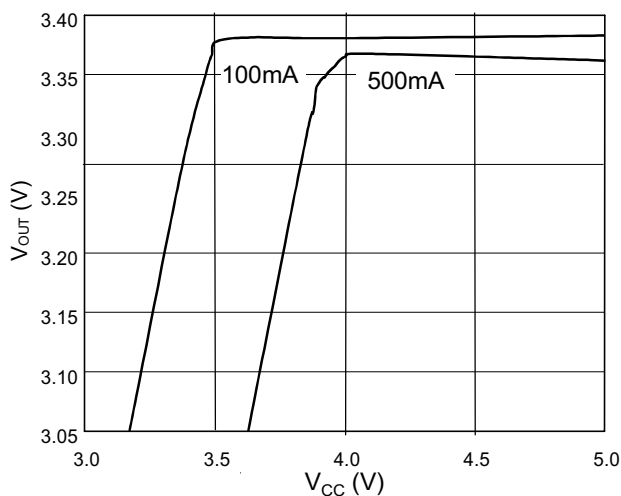

Fig. 11 V_{CC} Line Regulation

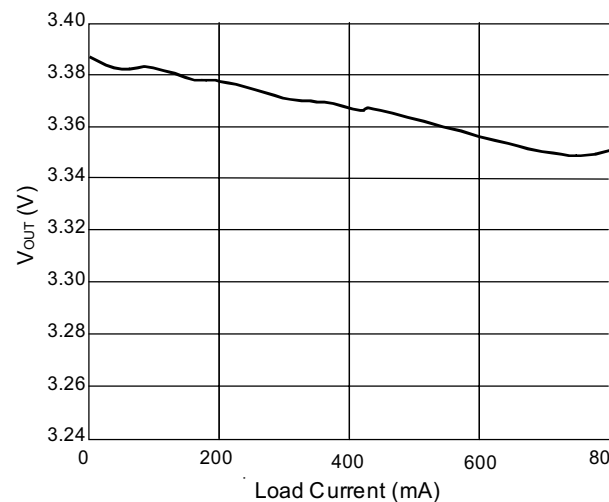

Fig. 10 V_{CC} Load Regulation

TYPICAL PERFORMANCE CHARACTERISTICS (contd.)

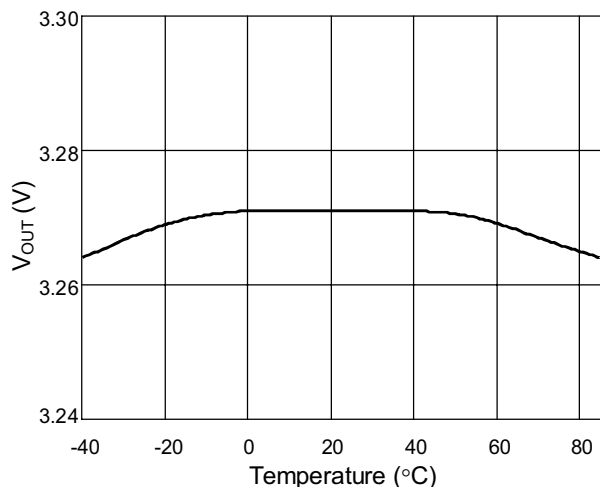
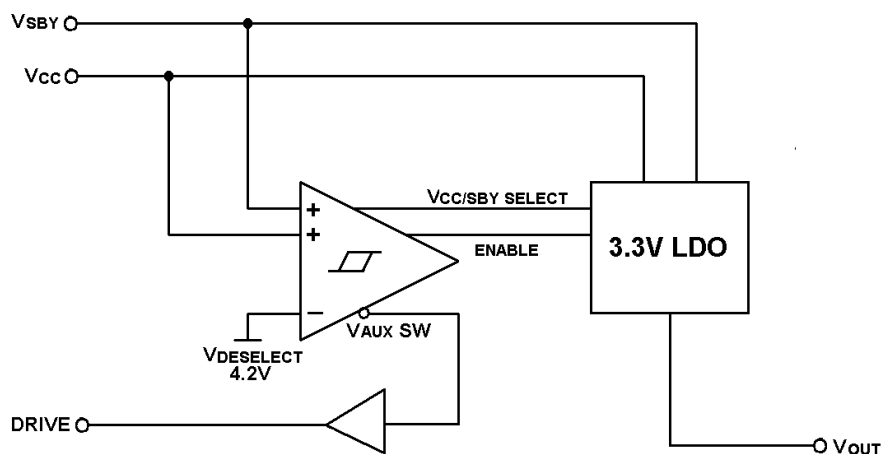

Fig. 13 Output Voltage vs. Temperature

BLOCK DIAGRAM



PIN DESCRIPTION

- PIN 1: VSBY - Standby supply voltage (5V) input for 3.3V regulator when VCC falls below VCCDES. Some NICs that operate in "Wake-On-LAN" mode get a 5V standby through a cable that connects directly to a specific header on the Motherboard.
- PIN 2: VCC - Primary supply voltage (5V) input for 3.3V regulator.
- PIN 3: VOUT - 3.3V regulated output voltage when either VCC or VSBY is present. When only VAUX (3.3V)

is present, VOUT voltage comes from VAUX through an internal low impedance switch.

- PIN 4: DRIVE - Signal for controlling external auxiliary switch. Active Low when internal regulator is disabled .
- PIN 5-8: GND - Negative reference for all voltages.

APPLICATIONS INFORMATION

The Requirement for External Capacitors

The selection of the output capacitor is based on two requirements: LDO compensation and the transition between power sources. During the takeover between sources, the output capacitor provides the loading. Therefore a larger output capacitor can improve the transition. And since the output capacitor plays the important role in the compensation of LDO, a 10 μ F Tantalum capacitor or larger is recommended.

The input capacitor is required to be as close to the IC as possible. The input capacitor can reduce the parasitic effect formed by the power supply output impedance or the trace. A 10 μ F Tantalum capacitor is a good choice. Additional ceramic capacitor can be placed close to input and output to reduce the high frequency noise. A 0.1 μ F is recommended.

The layout and Thermal Considerations

The SS6532 is housed in a thermally enhanced package where the GND pins (Pin5 to Pin8) are integrated to the leadframe. Generally, heat sinks are not available for most surface-mounted devices. Instead, they rely on the

printed-circuit board to provide the thermal path.

When the SS6532 operates normally, the

maximum power dissipation is

$$P_D = (V_{IN} - V_{OUT}) \times I_{OUT} = (5 - 3.3) \times 0.5 = 0.85W$$

At the maximum operation temperature, the thermal resistance seen by the device, or the combination of all the thermal paths, should be

$$R_{JA} < \frac{165 - 85}{0.85} = 94^{\circ}C/W .$$

When the device is mounted on a double-sided printed circuit board, the ground plane is the most used thermal path. To make sure the thermal resistance small enough and the shutdown function work normally, the thermal resistance between GND pins to GND plane should be as small as possible by means of adding more vias. And the GND plane should be at least 1 square centimeters of copper.

The layout of the SS6532 is shown in fig.19. In Fig. 21, the thermal resistance R_{JA} is 70.36 $^{\circ}C/W$ where the SS6532 is mounted on the double-sided PCB and measured under forced-air thermal chamber.

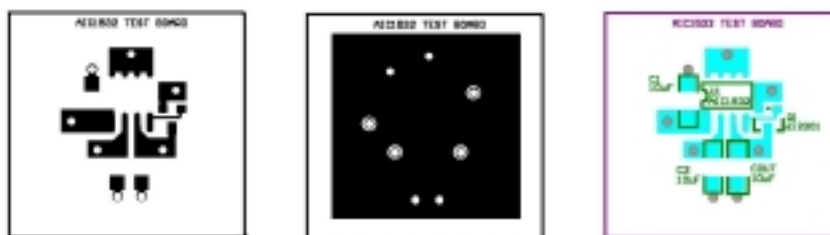

Fig.19 The layout for the SS6532.

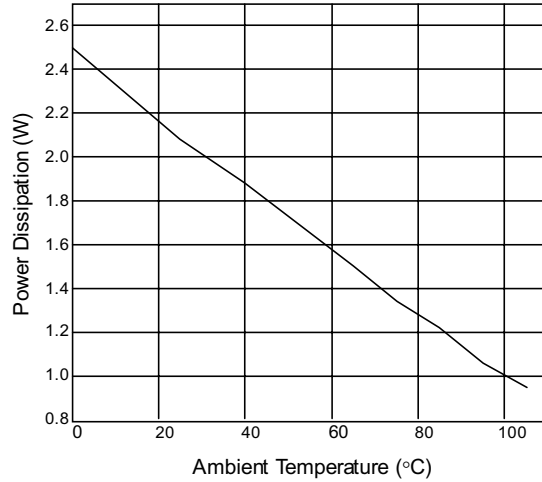

Fig.20 The thermal shutdown power dissipation vs. ambient temperature where R_{JA} is 70.36°C/W in the forced-air thermal chamber

Application circuits

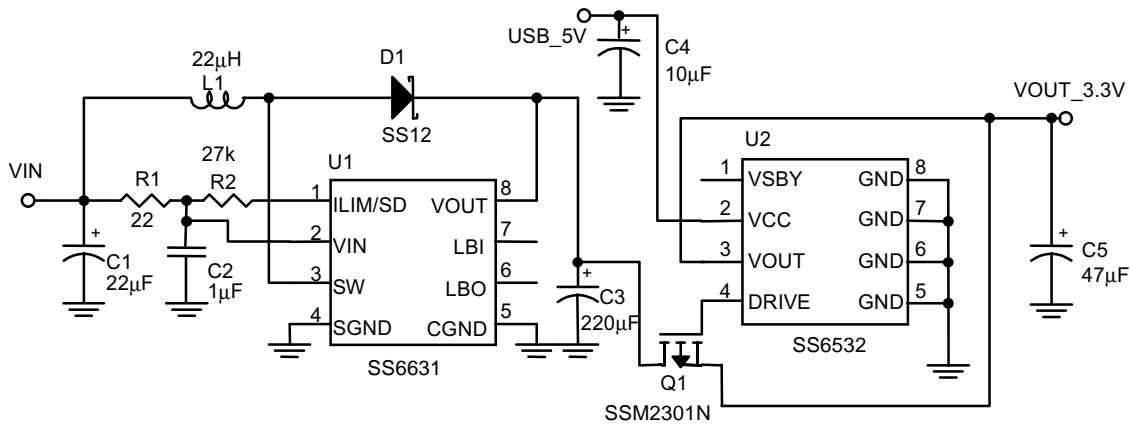

Fig. 21 The Step Up converter with OR function for dual power system

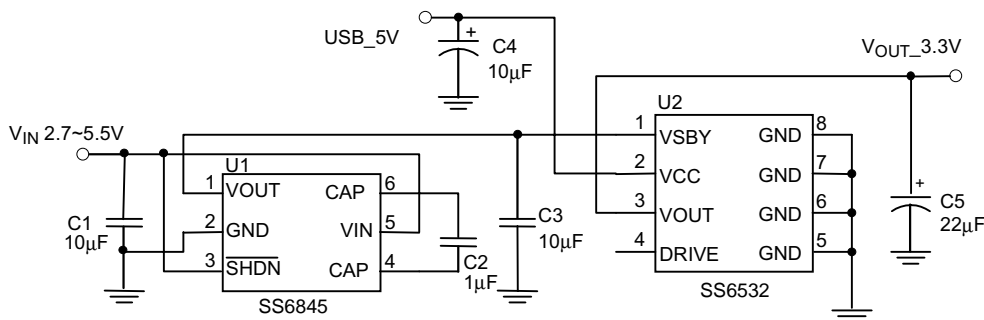
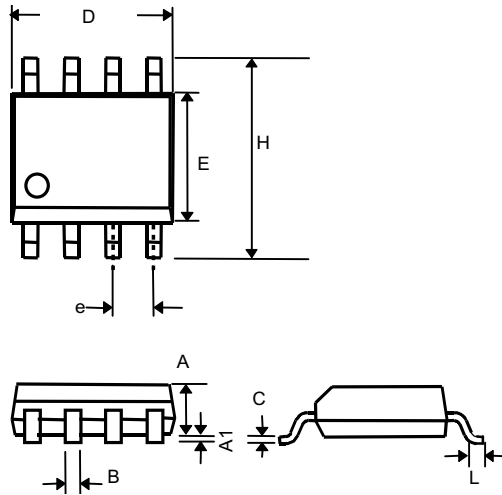

Fig. 22 The Step Up/Down converter with OR function for dual power system

PHYSICAL DIMENSIONS

8-LEAD PLASTIC SO (units: mm)



SYMBOL	MIN	MAX
A	1.35	1.75
A1	0.10	0.25
B	0.33	0.51
C	0.19	0.25
D	4.80	5.00
E	3.80	4.00
e	1.27(TYP)	
H	5.80	6.20
L	0.40	1.27

8-LEAD PLASTIC DIP (units: mm)

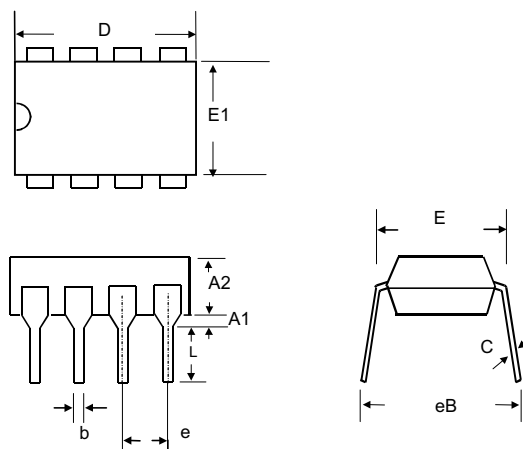

SYMBOL	MIN	MAX
A1	0.381	—
A2	2.92	4.96
b	0.35	0.56
C	0.20	0.36
D	9.01	10.16
E	7.62	8.26
E1	6.09	7.12
e	2.54 (TYP)	
eB	—	10.92
L	2.92	3.81

Information furnished by Silicon Standard Corporation is believed to be accurate and reliable. However, Silicon Standard Corporation makes no guarantee or warranty, express or implied, as to the reliability, accuracy, timeliness or completeness of such information and assumes no responsibility for its use, or for infringement of any patent or other intellectual property rights of third parties that may result from its use. Silicon Standard reserves the right to make changes as it deems necessary to any products described herein for any reason, including without limitation enhancement in reliability, functionality or design. No license is granted, whether expressly or by implication, in relation to the use of any products described herein or to the use of any information provided herein, under any patent or other intellectual property rights of Silicon Standard Corporation or any third parties.