

# 16 $\mu$ A IQ, 1.2A PWM Step-Down DC-DC Converters

## General Description

The MAX1556/MAX1557 are low-operating-current (16 $\mu$ A), fixed-frequency step-down regulators. High efficiency, low-quiescent operating current, low dropout, and minimal (27 $\mu$ A) quiescent current in dropout make these converters ideal for powering portable devices from 1-cell Li-ion or 3-cell alkaline/NiMH batteries. The MAX1556 delivers up to 1.2A; has pin-selectable 1.8V, 2.5V, and 3.3V outputs; and is also adjustable. The MAX1557 delivers up to 600mA; has pin-selectable 1V, 1.3V, and 1.5V outputs; and is also adjustable.

The MAX1556/MAX1557 contain a low-on-resistance internal MOSFET switch and synchronous rectifier to maximize efficiency and dropout performance while minimizing external component count. A proprietary topology offers the benefits of a high fixed-frequency operation while still providing excellent efficiency at both light and full loads. A 1MHz PWM switching frequency keeps components small. Both devices also feature an adjustable soft-start to minimize battery transient loading.

The MAX1556/MAX1557 are available in a tiny 10-pin TDFN (3mm x 3mm) package.

## Applications

PDA's and Palmtop Computers  
Cell Phones and Smart Phones  
Digital Cameras and Camcorders  
Portable MP3 and DVD Players  
Hand-Held Instruments

## Typical Operating Circuit

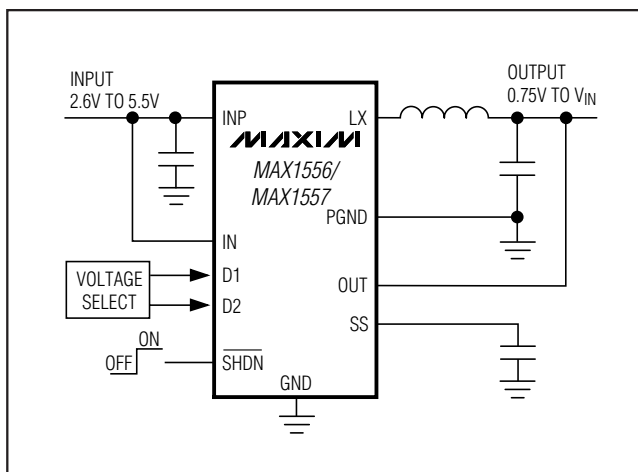

## Features

- ◆ Up to 97% Efficiency
- ◆ 95% Efficiency at 1mA Load Current
- ◆ Low 16 $\mu$ A Quiescent Current
- ◆ 1MHz PWM Switching
- ◆ Tiny 3.3 $\mu$ H Inductor
- ◆ Selectable 3.3V, 2.5V, 1.8V, 1.5V, 1.3V, 1.0V, and Adjustable Output
- ◆ 1.2A Guaranteed Output Current (MAX1556)
- ◆ Voltage Positioning Optimizes Load-Transient Response
- ◆ Low 27 $\mu$ A Quiescent Current in Dropout
- ◆ Low 0.1 $\mu$ A Shutdown Current
- ◆ No External Schottky Diode Required
- ◆ Analog Soft-Start with Zero Overshoot Current
- ◆ Small, 10-Pin, 3mm x 3mm TDFN Package

## Ordering Information

PART	TEMP RANGE	PIN-PACKAGE	TOP MARK
MAX1556ETB	-40°C to +85°C	10 TDFN-EP* (T1033-1)	ACQ
MAX1557ETB	-40°C to +85°C	10 TDFN-EP* (T1033-1)	ACR

\*EP = Exposed paddle.

## Pin Configuration

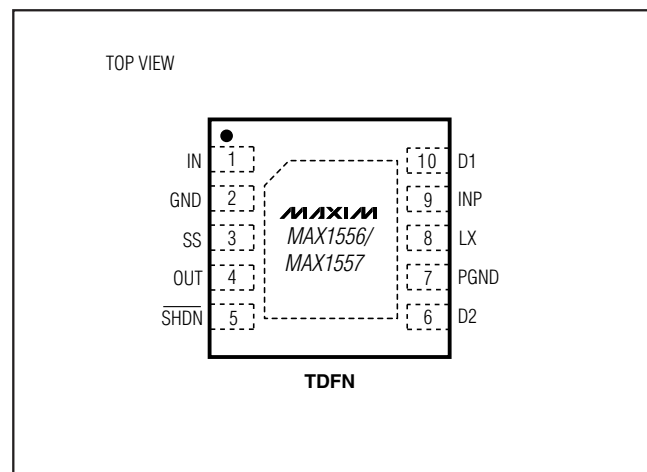

# 16 $\mu$ A IQ, 1.2A PWM DC-DC Step-Down Converters

**MAX1556/MAX1557**

## ABSOLUTE MAXIMUM RATINGS

IN, INP, OUT, D2,  $\overline{\text{SHDN}}$  to GND .....-0.3V to +6.0V  
 SS, D1 to GND .....-0.3V to ( $V_{\text{IN}} + 0.3\text{V}$ )  
 PGND to GND .....-0.3V to +0.3V  
 LX Current (Note 1)..... $\pm 2.25\text{A}$   
 Output Short-Circuit Duration.....Continuous  
 Continuous Power Dissipation ( $T_A = +70^\circ\text{C}$ )  
 10-Pin TDFN (derate 24.4mW/ $^\circ\text{C}$  above +70 $^\circ\text{C}$ ) .....1951mW

Operating Temperature Range .....-40 $^\circ\text{C}$  to +85 $^\circ\text{C}$   
 Junction Temperature .....+150 $^\circ\text{C}$   
 Storage Temperature Range .....-65 $^\circ\text{C}$  to +150 $^\circ\text{C}$   
 Lead Temperature (soldering, 10s) .....+300 $^\circ\text{C}$

**Note 1:** LX has internal clamp diodes to GND and IN. Applications that forward bias these diodes should take care not to exceed the IC's package power-dissipation limits.

Stresses beyond those listed under "Absolute Maximum Ratings" may cause permanent damage to the device. These are stress ratings only, and functional operation of the device at these or any other conditions beyond those indicated in the operational sections of the specifications is not implied. Exposure to absolute maximum rating conditions for extended periods may affect device reliability.

## ELECTRICAL CHARACTERISTICS

( $V_{\text{IN}} = V_{\text{INP}} = V_{\overline{\text{SHDN}}} = 3.6\text{V}$ ,  $T_A = -40^\circ\text{C}$  to +85 $^\circ\text{C}$ . Typical values are at  $T_A = +25^\circ\text{C}$ , unless otherwise noted.) (Note 1)

PARAMETER	CONDITIONS		MIN	TYP	MAX	UNITS
Input Voltage			2.6		5.5	V
Undervoltage-Lockout Threshold	$V_{\text{IN}}$ rising and falling, 35mV hysteresis (typ)		2.20	2.35	2.55	V
Quiescent Supply Current	No switching, D1 = D2 = GND			16	25	$\mu\text{A}$
	Dropout			27	42	
Shutdown Supply Current	$\overline{\text{SHDN}} = \text{GND}$	$T_A = +25^\circ\text{C}$		0.1	1	$\mu\text{A}$
		$T_A = +85^\circ\text{C}$		0.1		
Output Voltage Range			0.75		$V_{\text{IN}}$	V
Output Accuracy	$T_A = 0^\circ\text{C}$ to +85 $^\circ\text{C}$ (Note 2)	No load	-0.25	+0.75	+1.75	%
		300mA load	-0.75	0	+0.75	
		600mA load	-1.5	-0.75	0	
		1200mA load, MAX1556 only	-2.75	-2.25	-1.25	
	$T_A = -40^\circ\text{C}$ to +85 $^\circ\text{C}$ (Note 2)	No load	-0.75		+2.25	
		300mA load	-1.5		+1.5	
		600mA load	-2.25		+0.50	
		1200mA load, MAX1556 only	-4.0		-1.0	
Maximum Output Current	MAX1556		1200			mA
	MAX1557		600			
OUT Bias Current	D1 = D2 = GND	$T_A = +25^\circ\text{C}$		0.01	0.1	$\mu\text{A}$
		$T_A = +85^\circ\text{C}$		0.01		
	For preset output voltages			3	4.5	
FB Threshold Accuracy	D1 = D2 = GND, $V_{\text{OUT}} = 0.75\text{V}$ at 300mA (typ), $T_A = 0^\circ\text{C}$ to +85 $^\circ\text{C}$	No load	-0.50	+0.75	+1.75	%
		300mA load	-1.2	0	+1.2	
		600mA load	-1.75	-0.75	+0.25	
		1200mA load, MAX1556 only	-3.25	-2.25	-1.25	
	D1 = D2 = GND, $V_{\text{OUT}} = 0.75\text{V}$ at 300mA (typ), $T_A = -40^\circ\text{C}$ to +85 $^\circ\text{C}$	No load	-1.25		+2.25	
		300mA load	-1.75		+1.50	
		600mA load	-2.75		+0.25	
		1200mA load, MAX1556 only	-4.25		-1.00	

# 16μA I<sub>Q</sub>, 1.2A PWM DC-DC Step-Down Converters

**MAX1556/MAX1557**

## ELECTRICAL CHARACTERISTICS (continued)

(V<sub>IN</sub> = V<sub>INP</sub> = V<sub>SHDN</sub> = 3.6V, T<sub>A</sub> = - 40°C to +85°C. Typical values are at T<sub>A</sub> = +25°C, unless otherwise noted.) (Note 1)

PARAMETER	CONDITIONS		MIN	TYP	MAX	UNITS
Line Regulation	MAX1556, D1 = IN, D2 = GND	V <sub>IN</sub> = 2.6V to 3.6V		-0.37		%
		V <sub>IN</sub> = 3.6V to 5.5V		0.33		
	MAX1557, D1 = IN, D2 = GND	V <sub>IN</sub> = 2.6V to 3.6V		-0.1		
		V <sub>IN</sub> = 3.6V to 5.5V		0.09		
p-Channel On-Resistance	MAX1556	V <sub>IN</sub> = 3.6V		0.19	0.35	Ω
		V <sub>IN</sub> = 2.6V		0.23		
	MAX1557	V <sub>IN</sub> = 3.6V		0.35	0.7	
		V <sub>IN</sub> = 2.6V		0.42		
n-Channel On-Resistance	V <sub>IN</sub> = 3.6V			0.27	0.48	Ω
	V <sub>IN</sub> = 2.6V			0.33		
p-Channel Current-Limit Threshold	MAX1556		1.5	1.8	2.1	A
	MAX1557		0.8	1.0	1.2	
n-Channel Zero Crossing Threshold			20	35	45	mA
RMS LX Output Current	MAX1556				1.8	A <sub>RMS</sub>
	MAX1557				1.0	
LX Leakage Current	V <sub>IN</sub> = 5.5V, LX = GND or IN	T <sub>A</sub> = +25°C		0.1	10	μA
		T <sub>A</sub> = +85°C		0.1		
Maximum Duty Cycle			100			%
Minimum Duty Cycle					0	%
Internal Oscillator Frequency			0.9	1	1.1	MHz
SS Output Impedance	ΔV <sub>SS</sub> / I <sub>SS</sub> for I <sub>SS</sub> = 2μA		130	200	300	kΩ
SS Discharge Resistance	SHDN = GND, 1mA sink current			90	200	Ω
Thermal-Shutdown Threshold				+160		°C
Thermal-Shutdown Hysteresis				15		°C
<b>LOGIC INPUTS (D1, D2, SHDN)</b>						
Input-Voltage High	2.6V ≤ V <sub>IN</sub> ≤ 5.5V		1.4			V
Input-Voltage Low					0.4	V
Input Leakage	T <sub>A</sub> = +25°C			0.1	1	μA
	T <sub>A</sub> = +85°C			0.1		

**Note 1:** All units are 100% production tested at T<sub>A</sub> = +25°C. Limits over the operating range are guaranteed by design.

**Note 2:** For the MAX1556, 3.3V output accuracy is specified with a 4.2V input.

# 16 $\mu$ A IQ, 1.2A PWM DC-DC Step-Down Converters

MAX1556/MAX1557

## Typical Operating Characteristics

( $V_{IN} = V_{INP} = 3.6V$ ,  $D1 = D2 = \overline{SHDN} = IN$ , Circuits of Figures 2 and 3,  $T_A = +25^\circ C$ , unless otherwise noted.)

**EFFICIENCY vs. LOAD CURRENT WITH 3.3V OUTPUT**

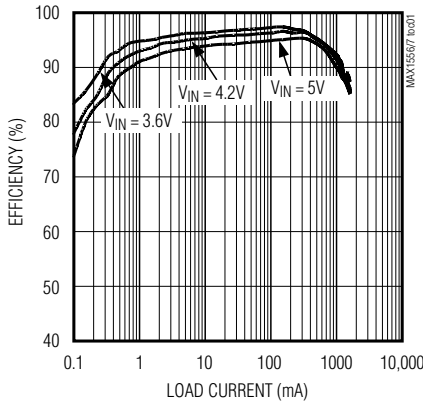

**EFFICIENCY vs. LOAD CURRENT WITH 2.5V OUTPUT**

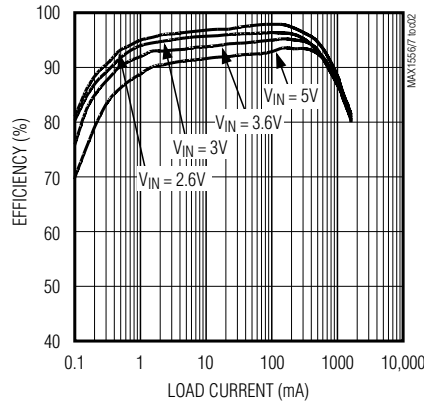

**EFFICIENCY vs. LOAD CURRENT WITH 1.8V OUTPUT**

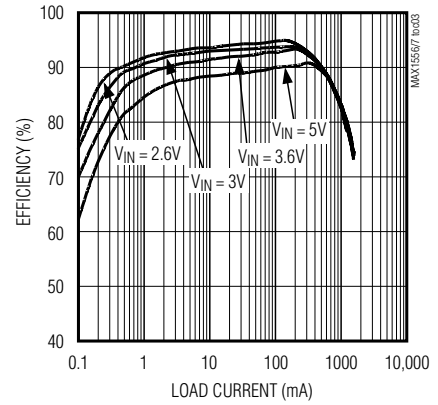

**EFFICIENCY vs. LOAD CURRENT WITH 1.0V OUTPUT (MAX1557)**

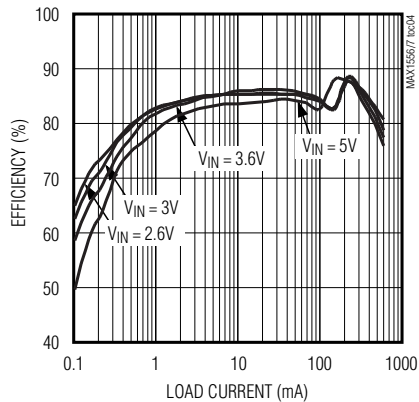

**OUTPUT VOLTAGE vs. LOAD CURRENT**

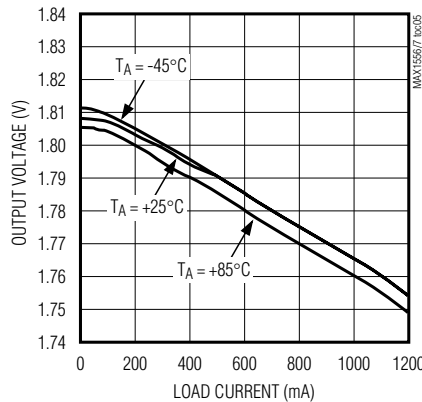

**OUTPUT VOLTAGE vs. INPUT VOLTAGE WITH 600mA LOAD**

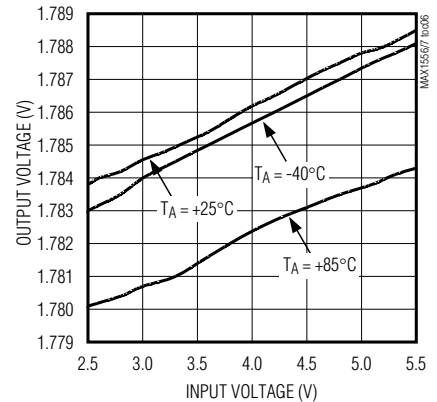

**OUTPUT VOLTAGE vs. INPUT VOLTAGE WITH NO LOAD**

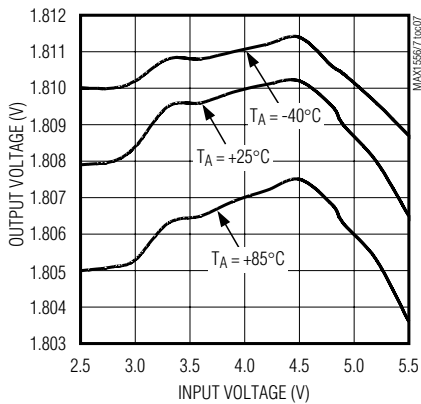

**SUPPLY CURRENT vs. INPUT VOLTAGE**

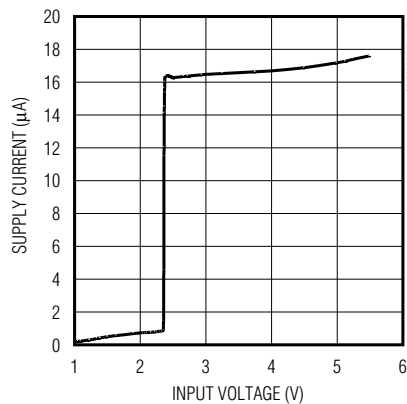

**HEAVY-LOAD SWITCHING WAVEFORMS**

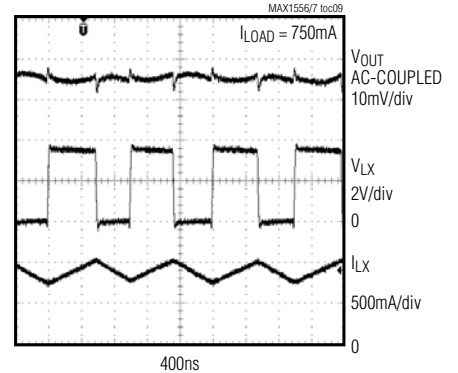

# 16µA IQ, 1.2A PWM DC-DC Step-Down Converters

## Typical Operating Characteristics (continued)

( $V_{IN} = V_{INP} = 3.6V$ ,  $D1 = D2 = \overline{SHDN} = IN$ , Circuits of Figures 2 and 3,  $T_A = +25^\circ C$ , unless otherwise noted.)

MAX1556/MAX1557

**LIGHT-LOAD SWITCHING WAVEFORMS**

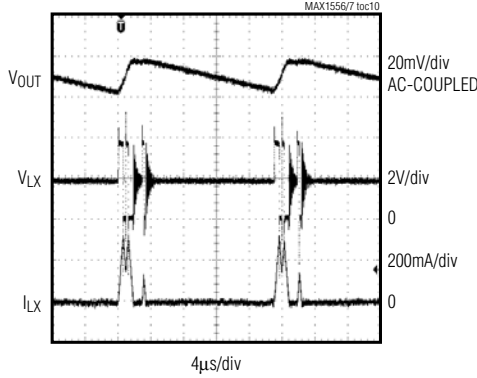

**SOFT-START/SHUTDOWN WAVEFORMS**

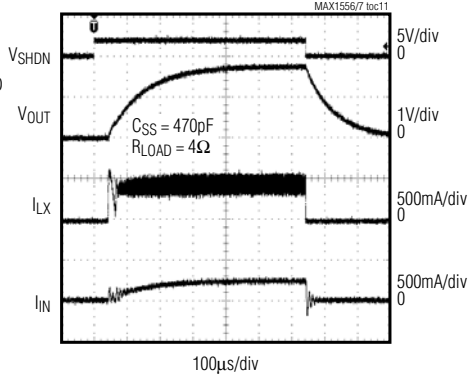

**SOFT-START RAMP TIME vs. C<sub>SS</sub>**

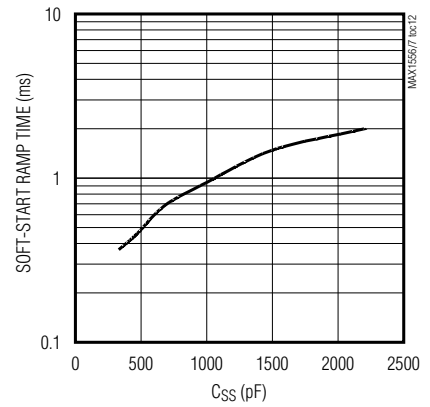

**LOAD TRANSIENT**

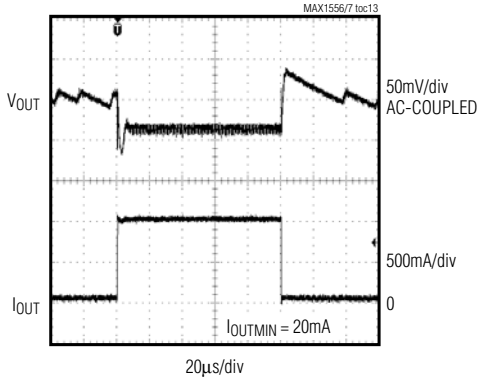

**LOAD TRANSIENT**

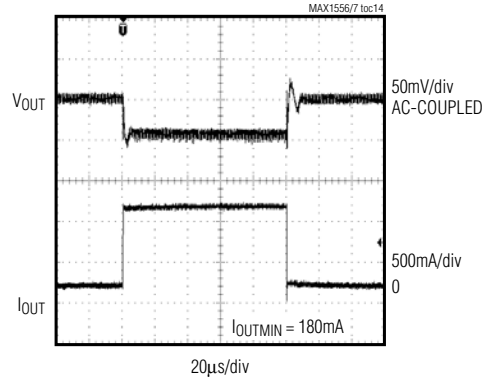

**LINE TRANSIENT**

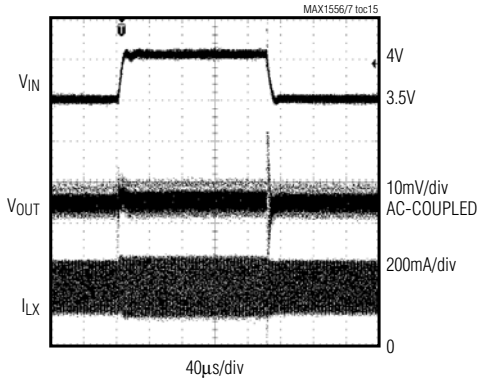

**BODE PLOT**

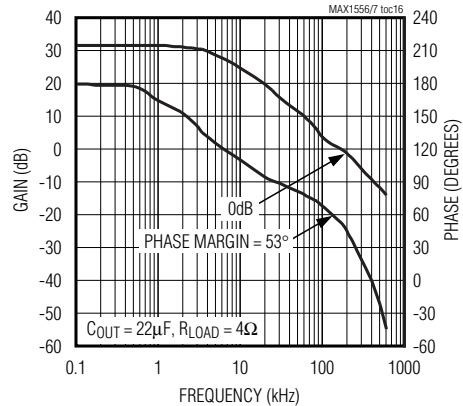

# 16 $\mu$ A IQ, 1.2A PWM DC-DC Step-Down Converters

MAX1556/MAX1557

## Pin Description

PIN	NAME	FUNCTION
1	IN	Supply Voltage Input. Connect to a 2.6V to 5.5V source.
2	GND	Ground. Connect to PGND.
3	SS	Soft-Start Control. Connect a 1000pF capacitor ( $C_{SS}$ ) from SS to GND to eliminate input-current overshoot during startup. $C_{SS}$ is required for normal operation of the MAX1556/MAX1557. For greater than 22 $\mu$ F total output capacitance, increase $C_{SS}$ to $C_{OUT} / 22,000$ for soft-start. SS is internally discharged through 200 $\Omega$ to GND in shutdown.
4	OUT	Output Sense Input. Connect to the output of the regulator. D1 and D2 select the desired output voltage through an internal feedback resistor-divider. The internal feedback resistor-divider remains connected in shutdown.
5	$\overline{\text{SHDN}}$	Shutdown Input. Drive $\overline{\text{SHDN}}$ low to enable low-power shutdown mode. Drive high or connect to IN for normal operation.
6	D2	OUT Voltage-Select Input. See Table 1.
7	PGND	Power Ground. Connect to GND.
8	LX	Inductor Connection. Connected to the drains of the internal power MOSFETs. High impedance in shutdown mode.
9	INP	Supply Voltage, High-Current Input. Connect to a 2.6V to 5.5V source. Bypass with a 10 $\mu$ F ceramic capacitor to PGND.
10	D1	OUT Voltage-Select Input. See Table 1.
EP	—	Exposed Paddle. Connect to ground plane. EP also functions as a heatsink. Solder to circuit-board ground plane to maximize thermal dissipation.

**Table 1. Output-Voltage-Select Truth Table**

D1	D2	MAX1556 V <sub>OUT</sub>	MAX1557 V <sub>OUT</sub>
0	0	Adjustable from 0.75V to $V_{IN}$	
0	1	3.3V	1.5V
1	0	2.5V	1.3V
1	1	1.8V	1.0V

A zero represents  $D_+$  being driven low or connected to GND.  
A 1 represents  $D_+$  being driven high or connected to IN.

## Detailed Description

The MAX1556/MAX1557 synchronous step-down converters deliver a guaranteed 1.2A/600mA at output voltages from 0.75V to  $V_{IN}$ . They use a 1MHz PWM current-mode control scheme with internal compensation, allowing for tiny external components and a fast transient response. At light loads the MAX1556/MAX1557 automatically switch to pulse-skipping mode to keep the quiescent supply current as low as 16 $\mu$ A. Figures 2 and 3 show the typical application circuits.

## Control Scheme

During PWM operation the converters use a fixed-frequency, current-mode control scheme. The heart of the current-mode PWM controller is an open-loop, multiple-input comparator that compares the error-amp voltage feedback signal against the sum of the amplified current-sense signal and the slope-compensation ramp. At the beginning of each clock cycle, the internal high-side p-channel MOSFET turns on until the PWM comparator trips. During this time the current in the inductor ramps up, sourcing current to the output and storing energy in the inductor's magnetic field. When the p-channel turns off, the internal low-side n-channel MOSFET turns on. Now the inductor releases the stored energy while the current ramps down, still providing current to the output. The output capacitor stores charge when the inductor current exceeds the load and discharges when the inductor current is lower than the load. Under overload conditions, when the inductor current exceeds the current limit, the high-side MOSFET is turned off and the low-side MOSFET remains on until the next clock cycle.

# 16µA IQ, 1.2A PWM DC-DC Step-Down Converters

**MAX1556/MAX1557**

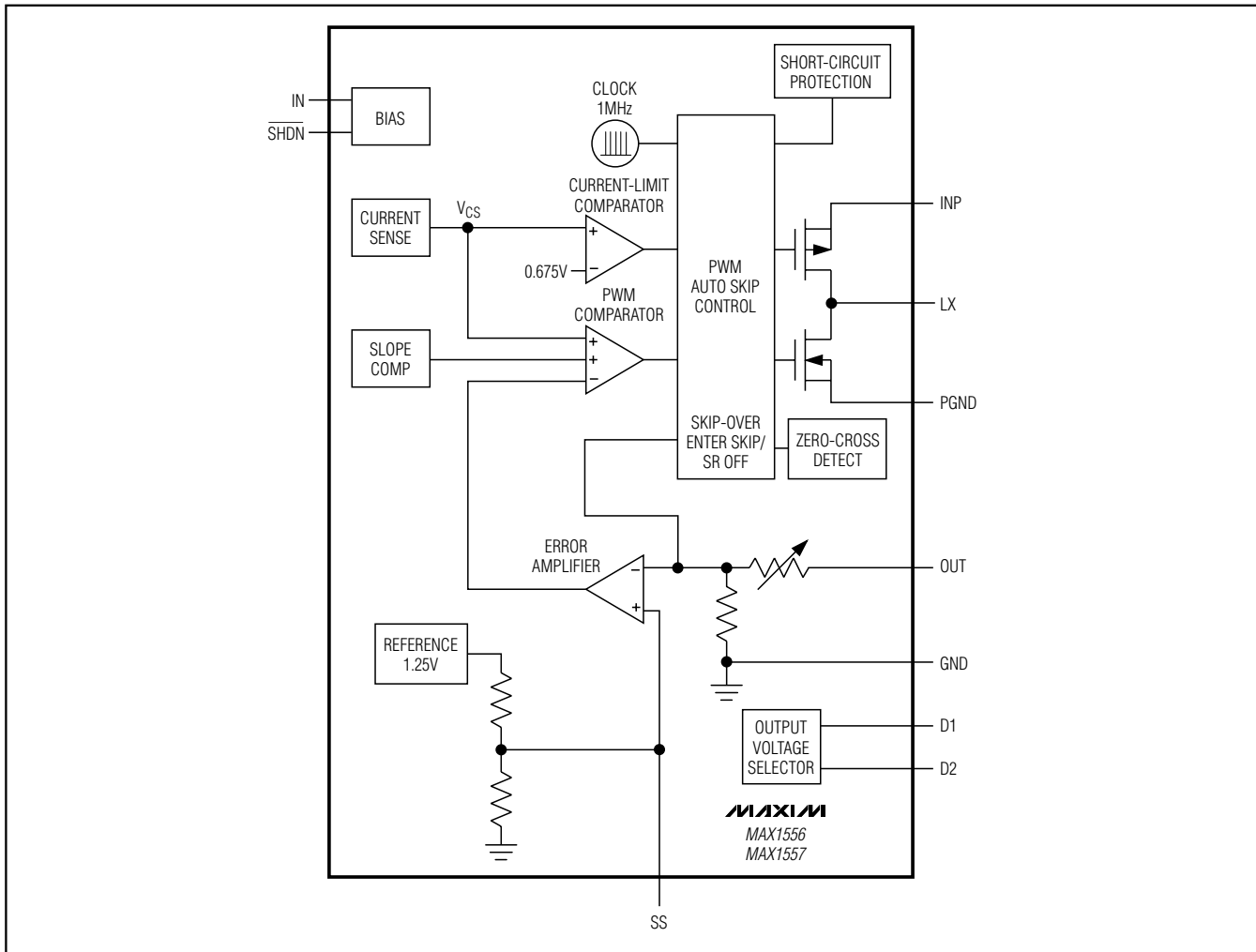

Figure 1. Functional Diagram

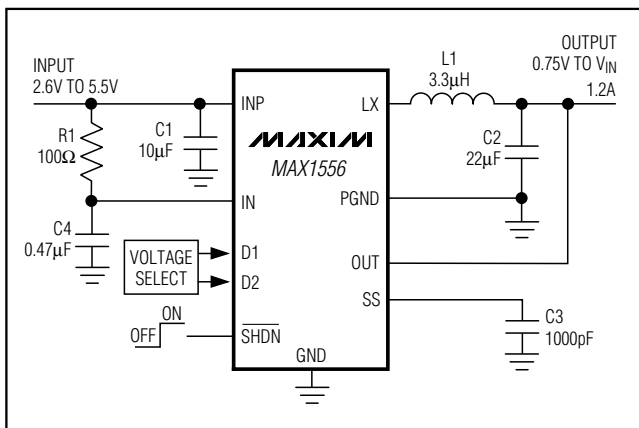

Figure 2. MAX1556 Typical Application Circuit

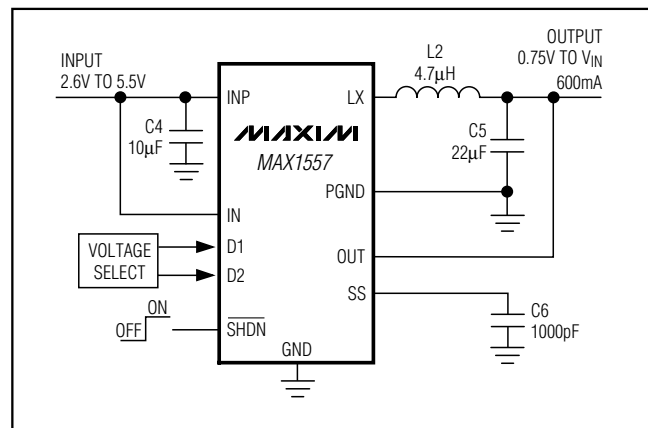

Figure 3. MAX1557 Typical Application Circuit

# 16 $\mu$ A IQ, 1.2A PWM DC-DC Step-Down Converters

MAX1556/MAX1557

As the load current decreases, the converters enter a pulse-skip mode in which the PWM comparator is disabled. At light loads, efficiency is enhanced by a pulse-skip mode in which switching occurs only as needed to service the load. Quiescent current in skip mode is typically 16 $\mu$ A. See the Light-Load Switching Waveforms and Load Transient graphs in the *Typical Operating Characteristics*.

## Load-Transient Response/ Voltage Positioning

The MAX1556/MAX1557 match the load regulation to the voltage droop seen during transients. This is sometimes called voltage positioning. The load line used to achieve this behavior is shown in Figures 4 and 5. There is minimal overshoot when the load is removed and minimal voltage drop during a transition from light load to full load. Additionally, the MAX1556 and MAX1557 use a wide-bandwidth feedback loop to respond more quickly to a load transient than regulators using conventional integrating feedback loops (see Load Transient in the *Typical Operating Characteristics*).

The MAX1556/MAX1557 use of a wide-band control loop and voltage positioning allows superior load-transient response by minimizing the amplitude and duration of overshoot and undershoot in response to load transients. Other DC-DC converters, with high gain-control loops, use external compensation to maintain tight DC load regulation but still allow large voltage droops of 5% or greater for several hundreds of microseconds during transients. For example, if the load is a CPU running at 600MHz, then a dip lasting 100 $\mu$ s corresponds to 60,000 CPU clock cycles.

Voltage positioning on the MAX1556/MAX1557 allows up to 2.25% (typ) of load-regulation voltage shift but has no further transient droop. Thus, during load transients, the voltage delivered to the CPU remains within spec more effectively than with other regulators that might have tighter initial DC accuracy. In summary, a 2.25% load regulation with no transient droop is much better than a converter with 0.5% load regulation and 5% or more of voltage droop during load transients. Load-transient variation can be seen only with an oscilloscope (see the *Typical Operating Characteristics*), while DC load regulation read by a voltmeter does not show how the power supply reacts to load transients.

## Dropout/100% Duty-Cycle Operation

The MAX1556/MAX1557 function with a low input-to-output voltage difference by operating at 100% duty cycle. In this state, the high-side p-channel MOSFET is always on. This is particularly useful in battery-powered applications with a 3.3V output. The system and load might

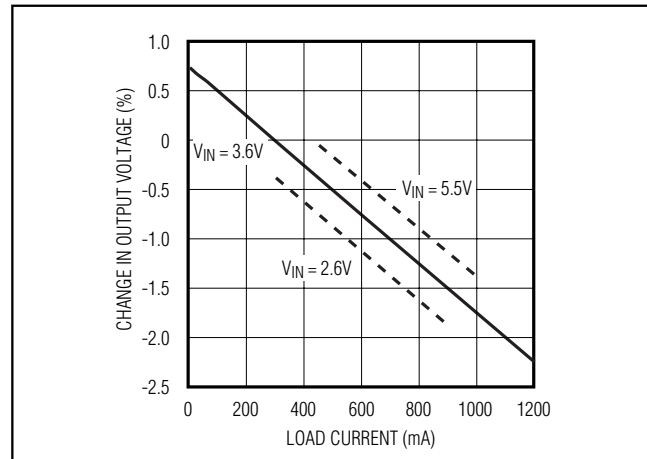

Figure 4. MAX1556 Voltage-Positioning Load Line

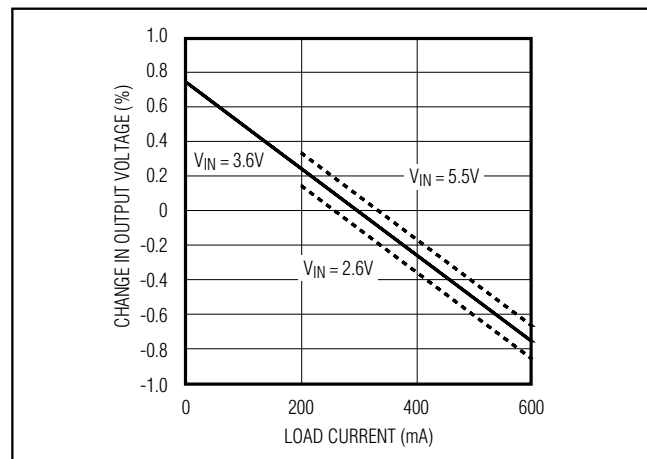

Figure 5. MAX1557 Voltage-Positioning Load Line

operate normally down to 3V or less. The MAX1556/MAX1557 allow the output to follow the input battery voltage as it drops below the regulation voltage. The quiescent current in this state rises minimally to only 27 $\mu$ A (typ), which aids in extending battery life. This dropout/100% duty-cycle operation achieves long battery life by taking full advantage of the entire battery range.

The input voltage required to maintain regulation is a function of the output voltage and the load. The difference between this minimum input voltage and the output voltage is called the dropout voltage. The dropout voltage is therefore a function of the on-resistance of the internal p-channel MOSFET ( $R_{DS(ON)P}$ ) and the inductor resistance (DCR).

$$V_{\text{DROPOUT}} = I_{\text{OUT}} \times (R_{\text{DS(ON)P}} + \text{DCR})$$



# 16μA IQ, 1.2A PWM DC-DC Step-Down Converters

MAX1556/MAX1557

**Table 2. Inductor Selection**

MANUFACTURER	PART	VALUE (μH)	DCR (mΩ)	ISAT (mA)	SIZE (mm)	SHIELDED
Taiyo Yuden	LMNP04SB3R3N	3.3	36	1300	5 x 5 x 2.0	Yes
Taiyo Yuden	LMNP04SB4R7N	4.7	50	1200	5 x 5 x 2.0	Yes
TOKO	D52LC	3.5	73	1340	5 x 5 x 2.0	Yes
TOKO	D52LC	4.7	87	1140	5 x 5 x 2.0	Yes
Sumida	CDRH3D16	4.7	50	1200	3.8 x 3.8 x 1.8	Yes
TOKO	D412F	4.7	100*	1200*	4.8 x 4.8 x 1.2	Yes
Murata	LQH32CN	4.7	97	790	2.5 x 3.2 x 2.0	No
Sumitomo	CXL180	4.7	70*	1000*	3.0 x 3.2 x 1.7	No
Sumitomo	CXLD140	4.7	100*	800*	2.8 x 3.2 x 1.5	No

\*Estimated based upon similar-valued prototype inductors.

(RDS(ON)P) is given in the *Electrical Characteristics*. DCR for a few recommended inductors is listed in Table 2.

### Soft-Start

The MAX1556/MAX1557 use soft-start to eliminate inrush current during startup, reducing transients at the input source. Soft-start is particularly useful for higher-impedance input sources such as Li+ and alkaline cells. Connect the required soft-start capacitor from SS to GND. For most applications using a 22μF output capacitor, connect a 1000pF capacitor from SS to GND. If a larger output capacitor is used, then use the following formula to find the value of the soft-start capacitor:

$$C_{SS} = \frac{C_{OUT}}{22000}$$

Soft-start is implemented by exponentially ramping up the output voltage from 0 to  $V_{OUT(NOM)}$  with a time constant equal to  $C_{SS}$  times  $200k\Omega$  (see the *Typical Operating Characteristics*). Assuming three time constants to full output voltage, use the following formula to calculate the soft-start time:

$$t_{SS} = 600 \times 10^3 \times C_{SS}$$

### Shutdown Mode

Connecting  $\overline{SHDN}$  to GND or logic low places the MAX1556/MAX1557 in shutdown mode and reduces supply current to 0.1μA. In shutdown, the control circuitry and the internal p-channel and n-channel MOSFETs turn off and LX becomes high impedance. Connect  $\overline{SHDN}$  to IN or logic high for normal operation.

### Thermal Shutdown

As soon as the junction temperature of the MAX1556/MAX1557 exceeds +160°C, the ICs go into

thermal shutdown. In this mode the internal p-channel switch and the internal n-channel synchronous rectifier are turned off. The device resumes normal operation when the junction temperature falls below +145°C.

### Applications Information

The MAX1556/MAX1557 are optimized for use with small external components. The correct selection of inductors and input and output capacitors ensures high efficiency, low output ripple, and fast transient response.

### Adjusting the Output Voltage

The adjustable output is selected when  $D1 = D2 = 0$  and an external resistor-divider is used to set the output voltage (see Figure 6). The MAX1556/MAX1557 have a defined line- and load-regulation slope. The load regulation is for both preset and adjustable outputs and is described in the *Electrical Characteristics* table and Figures 4 and 5. The impact of the line-regulation slope can be reduced by applying a correction factor to the feedback resistor equation.

First, calculate the correction factor,  $k$ , by plugging the desired output voltage into the following formula:

$$k = 1.06 \times 10^{-2}V \times \left( \frac{V_{OUTPUT} - 0.75V}{3.6V} \right)$$

$k$  represents the shift in the operating point at the feedback node (OUT).

Select the lower feedback resistor,  $R3$ , to be  $\leq 35.7k\Omega$  to ensure stability and solve for  $R2$ :

$$\left( \frac{0.75V - k}{V_{OUTPUT}} \right) = \frac{R3}{(R3 + R2)}$$

# 16 $\mu$ A IQ, 1.2A PWM DC-DC Step-Down Converters

MAX1556/MAX1557

## Inductor Selection

A 4.7 $\mu$ H inductor with a saturation current of at least 800mA is recommended for the MAX1557 full-load (600mA) application. For the MAX1556 application with 1.2A full load, use a 3.3 $\mu$ H inductor with at least 1.34A saturation current. For lower full-load currents the inductor current rating can be reduced. For maximum efficiency, the inductor's resistance (DCR) should be as low as possible. Please note that the core material differs among different manufacturers and inductor types and has an impact on the efficiency. See Table 2 for recommended inductors and manufacturers.

## Capacitor Selection

Ceramic input and output capacitors are recommended for most applications. For best stability over a wide temperature range, use capacitors with an X5R or better dielectric due to their small size, low ESR, and low temperature coefficients.

## Output Capacitor

The output capacitor  $C_{OUT}$  is required to keep the output voltage ripple small and to ensure regulation loop stability.  $C_{OUT}$  must have low impedance at the switching frequency. A 22 $\mu$ F ceramic output capacitor is recommended for most applications. If a larger output capacitor is used, then paralleling smaller capacitors is suggested to keep the effective impedance of the capacitor low at the switching frequency.

## Input Capacitor

Due to the pulsating nature of the input current in a buck converter, a low-ESR input capacitor at INP is required for input voltage filtering and to minimize interference with other circuits. The impedance of the input capacitor  $C_{INP}$  should be kept very low at the switching frequency. A minimum value of 10 $\mu$ F is recommended at INP for most applications. The input capacitor can be increased for better input filtering.

## IN Input Filter

In all MAX1557 applications, connect INP directly to IN and bypass INP as described in the *Input Capacitor* section. No additional bypass capacitor is required at IN. For applications using the MAX1556, an RC filter between INP and IN keeps power-supply noise from entering the IC. Connect a 100 $\Omega$  resistor between INP and IN, and connect a 0.47 $\mu$ F capacitor from IN to GND.

## Soft-Start Capacitor

The soft-start capacitor,  $C_{SS}$ , is required for proper operation of the MAX1556/MAX1557. The recommended value of  $C_{SS}$  is discussed in the *Soft-Start* section. Soft-start times for various soft-start capacitors are shown in the *Typical Operating Characteristics*.

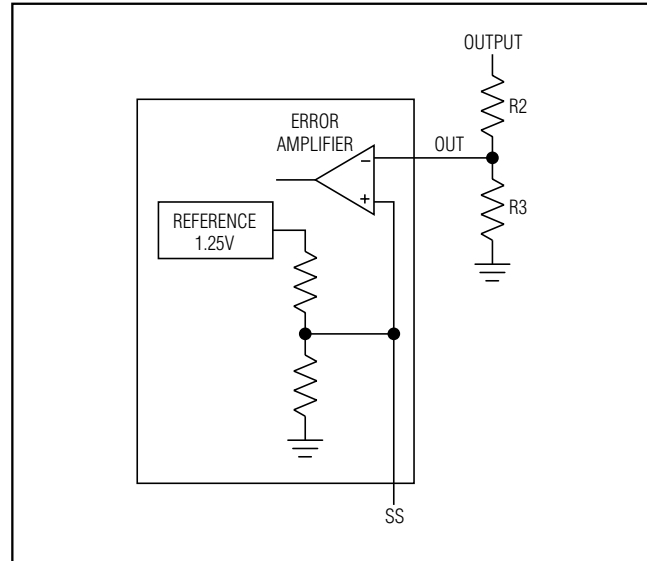

Figure 6. Adjustable Output Voltage

## PC Board Layout and Routing

Due to fast-switching waveforms and high-current paths, careful PC board layout is required. An evaluation kit (MAX1556EVKIT) is available to speed design.

When laying out a board, minimize trace lengths between the IC, the inductor, the input capacitor, and the output capacitor. Keep these traces short, direct, and wide. Keep noisy traces, such as the LX node trace, away from OUT. The input bypass capacitors should be placed as close to the IC as possible. Connect GND to the exposed paddle and star PGND and GND together at the output capacitor. The ground connections of the input and output capacitors should be as close together as possible.

## Chip Information

TRANSISTOR COUNT: 7567

PROCESS: BiCMOS

# 16µA IQ, 1.2A PWM DC-DC Step-Down Converters

## Package Information

(The package drawing(s) in this data sheet may not reflect the most current specifications. For the latest package outline information, go to [www.maxim-ic.com/packages](http://www.maxim-ic.com/packages).

**MAX1556/MAX1557**

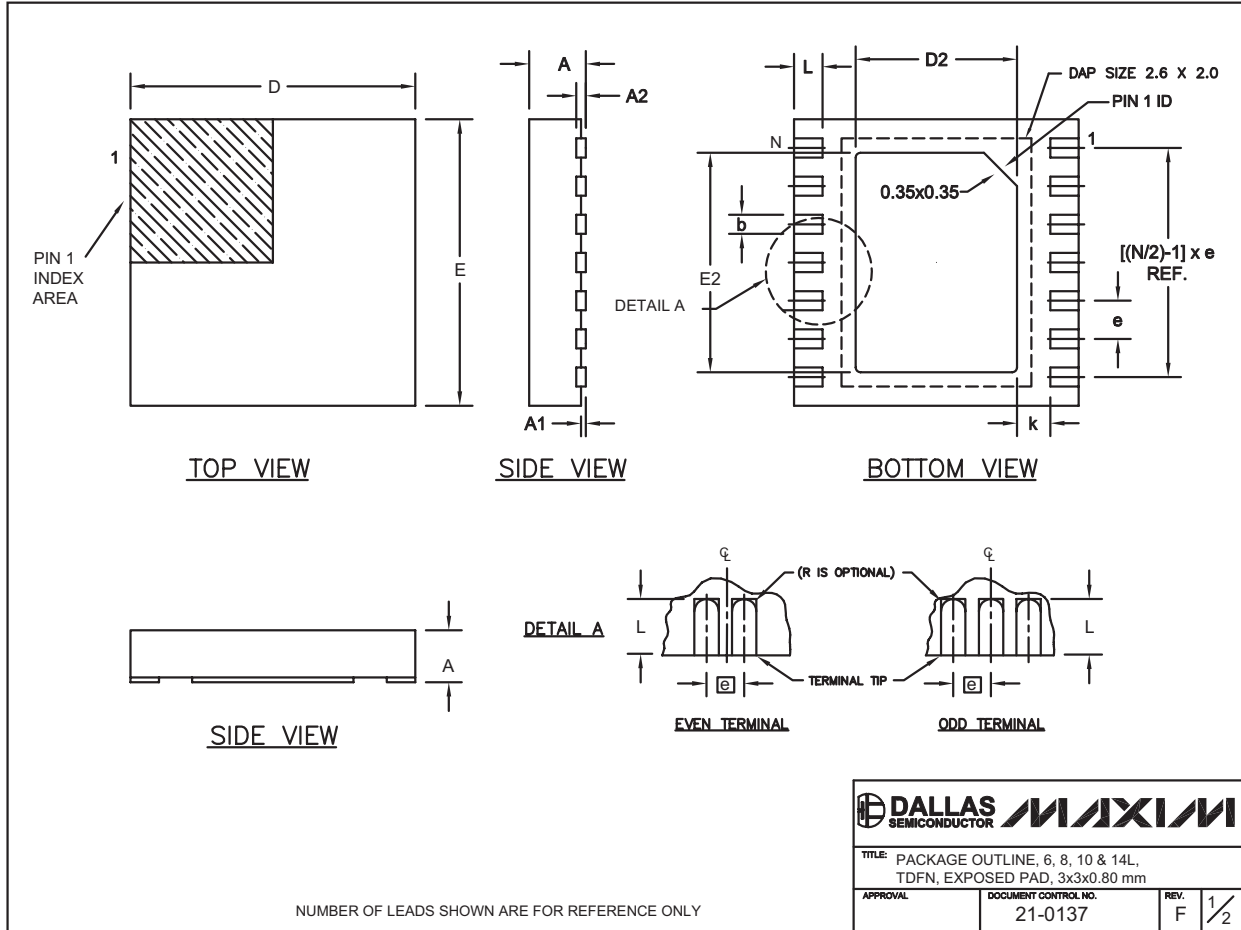

# 16 $\mu$ A IQ, 1.2A PWM DC-DC Step-Down Converters

MAX1556/MAX1557

## Package Information (continued)

(The package drawing(s) in this data sheet may not reflect the most current specifications. For the latest package outline information, go to [www.maxim-ic.com/packages](http://www.maxim-ic.com/packages).

COMMON DIMENSIONS		
SYMBOL	MIN.	MAX.
A	0.70	0.80
D	2.90	3.10
E	2.90	3.10
A1	0.00	0.05
L	0.20	0.40
k	0.25 MIN.	
A2	0.20 REF.	

PACKAGE VARIATIONS							
PKG. CODE	N	D2	E2	e	JEDEC SPEC	b	[(N/2)-1] x e
T633-1	6	1.50 $\pm$ 0.10	2.30 $\pm$ 0.10	0.95 BSC	MO229 / WEEA	0.40 $\pm$ 0.05	1.90 REF
T833-1	8	1.50 $\pm$ 0.10	2.30 $\pm$ 0.10	0.65 BSC	MO229 / WEEC	0.30 $\pm$ 0.05	1.95 REF
T1033-1	10	1.50 $\pm$ 0.10	2.30 $\pm$ 0.10	0.50 BSC	MO229 / WEED-3	0.25 $\pm$ 0.05	2.00 REF
T1433-1	14	1.70 $\pm$ 0.10	2.30 $\pm$ 0.10	0.40 BSC	----	0.20 $\pm$ 0.03	2.40 REF
T1433-2	14	1.70 $\pm$ 0.10	2.30 $\pm$ 0.10	0.40 BSC	----	0.20 $\pm$ 0.03	2.40 REF

### NOTES:

- ALL DIMENSIONS ARE IN mm. ANGLES IN DEGREES.
- COPLANARITY SHALL NOT EXCEED 0.08 mm.
- WARPAGE SHALL NOT EXCEED 0.10 mm.
- PACKAGE LENGTH/PACKAGE WIDTH ARE CONSIDERED AS SPECIAL CHARACTERISTIC(S).
- DRAWING CONFORMS TO JEDEC MO229, EXCEPT DIMENSIONS "D2" AND "E2", AND T1433-1 & T1433-2.
- "N" IS THE TOTAL NUMBER OF LEADS.

	
TITLE: PACKAGE OUTLINE, 6, 8, 10 & 14L, TDFN, EXPOSED PAD, 3x3x0.80 mm	
APPROVAL	DOCUMENT CONTROL NO. 21-0137
REV.	F 2/2

Maxim cannot assume responsibility for use of any circuitry other than circuitry entirely embodied in a Maxim product. No circuit patent licenses are implied. Maxim reserves the right to change the circuitry and specifications without notice at any time.

12 \_\_\_\_\_ **Maxim Integrated Products, 120 San Gabriel Drive, Sunnyvale, CA 94086 408-737-7600**