

1 SCOPE

This specification shall cover the characteristics of the ceramic resonator with the type ZTT6.00MT.

2 PART NO

PART NUMBER	CUSTOMER PART NO	SPECIFICATION NO
ZTT6.00MT		

3 OUTLINE DRAWING AND DIMENSIONS

3.1 Appearance: No visible damage and dirt.

3.2 Construction: Leads are soldered on electrode and body is molded by resin.

3.3 Except the chip(ceramic element, ceramic base, capacitance slice), the materials don't contain lead.

3.4 Dimensions

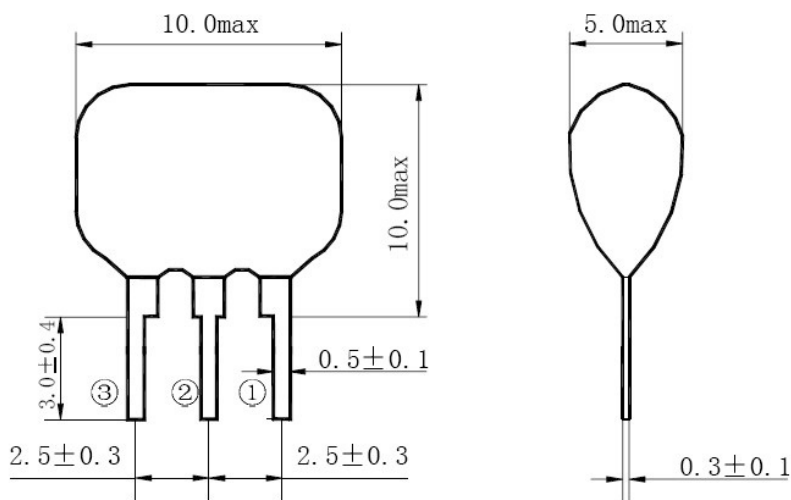

- ① Input
- ② Ground
- ③ Output

4 RATING AND ELECTRICAL SPECIFICATIONS

4.1 RATING

Items	Content
Withstanding Voltage (V)	50 (DC, 1min)
Insulation Resistance R_i (M Ω) min.	100 (100V, 1min)
Operating Temperature Range ($^{\circ}$ C)	-20~+80
Storage Temperature Range ($^{\circ}$ C)	-40~+85

4.2 ELECTRICAL SPECIFICATIONS

Items	Content
Oscillation Frequency f_{osc} (MHz)	6.000
Frequency Accuracy (%)	± 0.5
Resonant Impedance R_o (Ω) max.	25
Temperature Coefficient of Oscillation Frequency (%) max.	± 0.3 (Oscillation Frequency drift, -20~+80 $^{\circ}$ C)
Rating Voltage U_R (V) max.	6V DC
	15V p-p
Aging Rate (%) max.	± 0.3 (For Ten Years)

5 MEASUREMENT

5.1 Measurement Conditions: Parts shall be measured under a condition (Temp.: 20 \pm 15 $^{\circ}$ C, Humidity : 65 \pm 20% R.H.) unless the standard condition (Temp.: 25 \pm 3 $^{\circ}$ C, Humidity : 65 \pm 5% R.H.) is regulated to measure.

5.2 Test Circuit

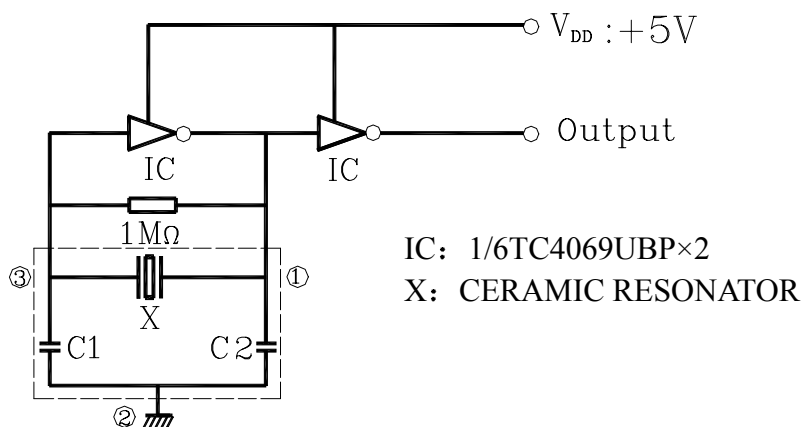

6 PHYSICAL AND ENVIRONMENTAL CHARACTERISTICS

No.	Item	Condition of Test	Performance Requirements
6.1	Humidity	Subject the resonator at $+40\text{ }^{\circ}\text{C} \pm 2\text{ }^{\circ}\text{C}$ and 90%-95% R.H. for 500h, resonator shall be measured after being placed in natural conditions for 1h.	It shall fulfill the specifications in Table 1.
6.2	High Temperature Exposure	Subject the resonator to $+85\text{ }^{\circ}\text{C} \pm 5\text{ }^{\circ}\text{C}$ for 500h, resonator shall be measured after being placed in natural conditions for 1hr.	It shall fulfill the specifications in Table 1.
6.3	Low Temperature Exposure	Subject the resonator to $-25\text{ }^{\circ}\text{C} \pm 5\text{ }^{\circ}\text{C}$ for 500h, resonator shall be measured after being placed in natural conditions for 1h.	It shall fulfill the specifications in Table 1.
6.4	Temperature Cycling	Subject the resonator to $-25\text{ }^{\circ}\text{C}$ for 30 min. followed by a high temperature of $+85\text{ }^{\circ}\text{C}$ for 30 min. Cycling shall be repeated 5 times. Resonator shall be measured after being placed in natural conditions for 1h.	It shall fulfill the specifications in Table 1.
6.5	Vibration	Subject the resonator to vibration for 2h each in x y and z axis with the amplitude of 1.5mm, the frequency shall be varied uniformly between the limits of 10Hz-55Hz and then resonator shall be measured.	It shall fulfill the specifications in Table 1.
6.6	Mechanical Shock	Resonator shall be measured after 3 times' random dropping from the height of 100cm on concrete floor.	No visible damage and it shall fulfill the specifications in Table 1.
6.7	Resistance to Soldering Heat	Lead terminals are immersed up to 2 mm from resonator's body in soldering bath of $260\text{ }^{\circ}\text{C} \pm 5\text{ }^{\circ}\text{C}$ for $5\text{s} \pm 1\text{s}$ and then resonator shall be measured after being placed in natural conditions for 1h	It shall fulfill the specifications in Table 1.
6.8	Solderability	Lead terminals are immersed up to 2mm from resonator's body in soldering bath of $250\text{ }^{\circ}\text{C} \pm 5\text{ }^{\circ}\text{C}$ for $2\text{s} \pm 0.5\text{s}$.	More than 95% of the terminal surface of the resonator shall be covered with fresh solder.

(To be continued)

6. PHYSICAL AND ENVIRONMENTAL CHARACTERISTICS

No.	Item	Condition of Test	Performance Requirements
6.9	Terminal Strength		
6.9.1	Terminal Pulling	Force of 5N is applied to each lead in axial direction for 10s \pm 1s.	No visible damage and it shall fulfill the specifications in Table 1.
6.9.2	Terminal Bending	When force of 5N is applied to each lead in axial direction, the lead shall be folded up 90° from the axial direction and folded back to the axial direction. The speed of folding shall be each 3s.	

Table 1

Item	Specification after test
Oscillation Frequency Change $\Delta f_{osc}/f_{osc}$ (%) max	± 0.3
Resonant Impedance R_o (Ω) max	25
Note: The limits in the above table are referenced to the initial measurements.	

7 PACKAGE

To protect the products in storage and transportation, it is necessary to pack them (outer and inner package). On paper pack, the following requirements are requested.

7.1 Dimensions and Mark

At the end of package, the warning (moisture proof, upward put) should be stick to it.

Dimensions and Mark (see below)

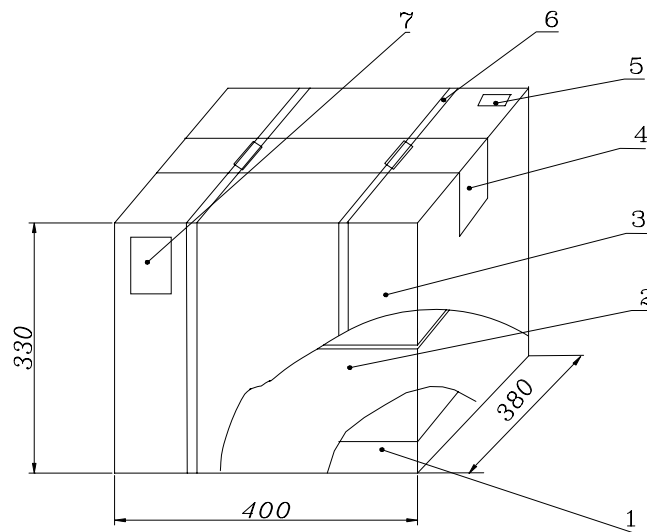

NO.	Name	Quantity	Notes
1	Inner Box	40	
2	Box	2	
3	Package	1	
4	Adhesive tape	1.2m	
5	Label	1	
6	Belt	2.9m	
7	Certificate of approval	1	

7.2 Section of package

Package is made of corrugated paper with thickness of 0.8cm. Package has 2 inner boxes, each has 20 inner box (each box for plastic bag).

7.3 Quantity of package

Per plastic bag 500 pieces
 Per inner box 2 plastic bag
 Per package 40 inner boxes

(40000 pieces of piezoelectric ceramic part)

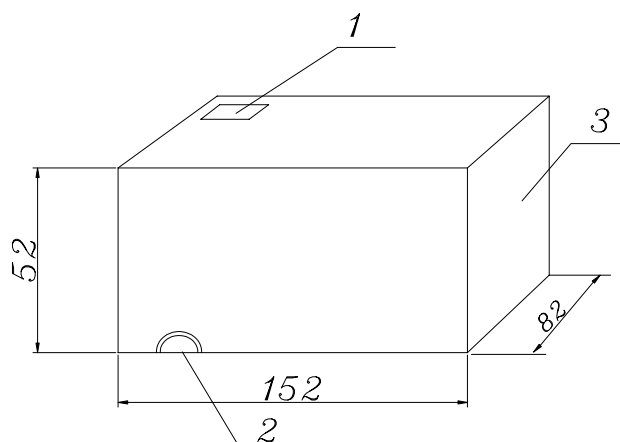
7.4 Inner box Dimensions

1.UNIT: mm

1	Label
2	QC Label
3	Inner Box

Pars shall be packaged in box with hold down tape upside. Part No., quantity and lot No.

8 OTHER

8.1 Caution of use

8.1.1 Do not use this product with bend. Please don't apply excess mechanical stress to the component and terminals at soldering.

8.1.2 The component may be damaged when an excess stress will be applied.

8.1.3 This specification mentions the quality of the component as a single unit. Please insure the component is thoroughly evaluated in your application circuit.

8.2 Notice

8.2.1 Please return one of this specification after your signature of acceptance.

8.2.2 When something gets doubtful with this specifications, we shall jointly work to get an agreement.