

PRODUCT NUMBER
SEE TABLE

$\phi .008/0.20$ (M) C (M) D (M)
MAX
AT TIPS

$.050$ [1.27]

DIM K $\pm .003$ [0.08]

-A-

DIM H $\pm .002$ [0.05]

$\phi .004/0.10$ A

-C-

$-.125^{+.005}$
 $-.000$ [3.18 $^{+0.13}$
 -0.00]

$\phi .005/0.13$ B

-D-

$.225$ [5.71] -B-

SEE NOTE 10

$.050 \pm .003$ [1.27 $\pm .08$]
TYP
NON-ACCUM.

DIM J

$.130$ [3.30]
INSERTION
DEPTH

NOTE 3

DRAIN HOLES
TYP

$\square .004/0.10$

SEE SHEET 3 FOR
LOCATOR/HOLDDOWN
VARIATIONS

DIM P
REF
HEIGHT ABOVE
BOARD

DIM N
 $\pm .010$ [.25]
TAIL LENGTH

DIM R

$\phi .010/0.25$ (M) A B
AT TIPS

DIM L

mat'l. code				surface		tolerance		projection		product family	
-				ISO 1302		ISO 406 ISO 1101				RIBCAGE	
ltr	ecn no	dr	date	tolerances unless otherwise specified							
L	J10329	CRG	6/6/01	angles	linear	.XX \pm .01/0.3		INCH/MM		title	
M	M05-0123	MHT	6/6/05			.XXX \pm .005/0.13				RIBCAGE III T/M VERT. HEADER ASS'Y	
N	M06-0225	ERE	06/12/06	0 \pm 2'		.XXXX \pm .0020/0.051		scale 4:1		sheet 1 of 6	
P	M06-0370	MHT	9/26/06	dr	M. CORNMAN	6/6/95				size	
R	M09-0058	MHT	4/04/09	engr	D. WHITING	6/6/95				95776	
S	N10-0122	YOH	5/10/10	chr	D. WHITING	6/6/95				A3	
				appd	D. WHITING	6/6/95				type Product Customer Drawing	
sheet	revision	S	S	S	S	S	S				
index	sheet	1	2	3	4	5	6				

PRODUCT NUMBER
SEE TABLE

SIZE	DIM H	DIM J	DIM K	DIM L
2X5	.275/6.99	.200/5.08	.372/9.45	.320/8.13
2X10	.525/13.34	.450/11.43	.622/15.80	.570/14.48
2X15	.775/19.68	.700/17.78	.872/22.15	.820/20.83
2X20	1.025/26.03	.950/24.13	1.122/28.50	1.070/27.18
2X25	1.275/32.38	1.200/30.48	1.372/34.85	1.320/33.53
2X30	1.525/38.74	1.450/36.83	1.622/41.20	1.570/39.88
2X35	1.775/45.08	1.700/43.18	1.872/47.55	1.820/46.23
2X40	2.025/51.43	1.950/49.53	2.122/53.90	2.070/52.58
2X45	2.275/57.78	2.200/55.88	2.372/60.25	2.320/58.93
2X50	2.525/64.14	2.450/62.23	2.622/66.60	2.570/65.28

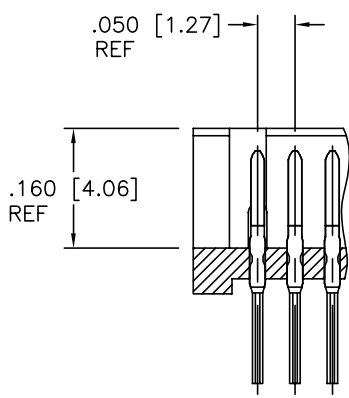

SECTION Y-Y

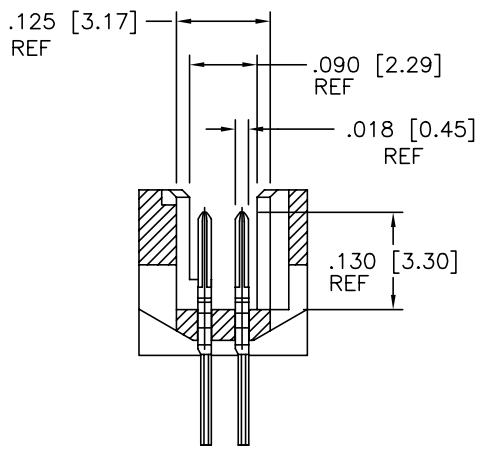

SECTION X-X
ROTATED 90° CW

mat'l. code		surface		tolerance		projection		product family	
-		ISO 1302		ISO 406 ISO 1101				RIBCAGE	
ltr	ecn no	dr	date	tolerances unless otherwise specified					
S				angles	linear	.XX±.01/0.3		title	
						.XXX±.005/0.13		RIBCAGE III T/M	
				0°±2'		.XXXX±.0020/0.051		VERT. HEADER ASS'Y	
				dr	M. CORNMAN	6/6/95		dwg no	
				enrg	D. WHITING	6/6/95		sheet 2 of 6	
				chr	D. WHITING	6/6/95		size	
				appd	D. WHITING	6/6/95		A3	
sheet index		revision sheet		type Product Customer Drawing					



FCJ
FCconnect.com

Copyright FCJ

PRODUCT NUMBER
SEE TABLE

LOCATOR/HOLDDOWN VARIATIONS

STYLE 1

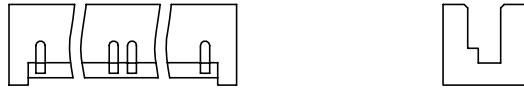

STYLE 6

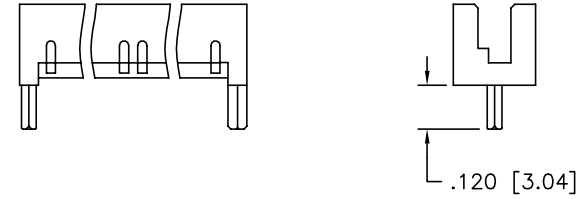

STYLE 2

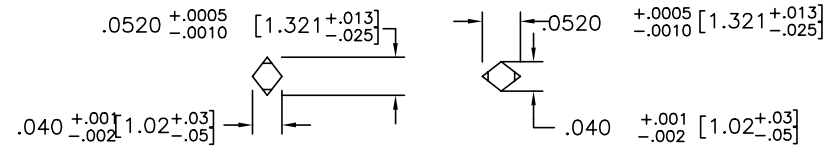
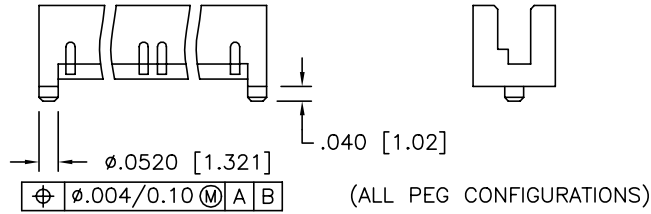

B

STYLE 7

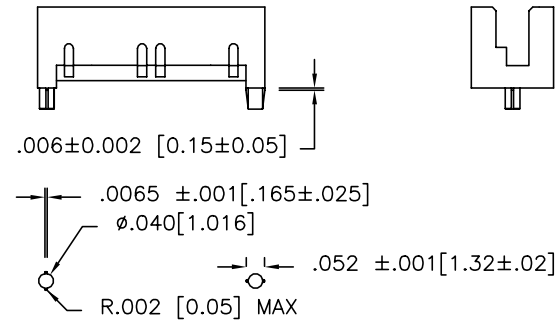

STYLE 4

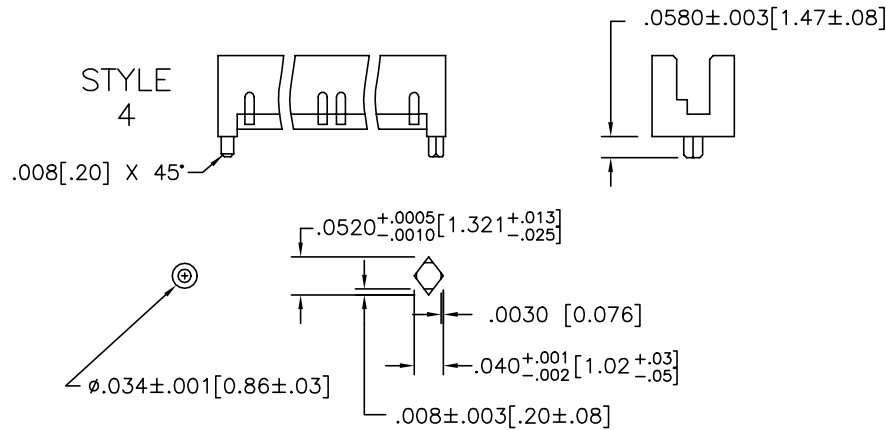

mat'l. code		surface		tolerance		projection		product family	
-		ISO 1302		ISO 406 ISO 1101				RIBCAGE	
ltr	ecn no	dr	date	tolerances unless otherwise specified					
S				angles	linear	$.XX \pm .01 / 0.3$ $.XXX \pm .005 / 0.13$ $.XXXX \pm .0020 / 0.051$			
				$0^\circ \pm 2'$		scale 4:1		title RIBCAGE III T/M VERT. HEADER ASS'Y	
		dr	M. CORNMAN	6/6/95			dwg no 95776		sheet 3 of 6 size A3
		enrg	D. WHITING	6/6/95			type Product Customer Drawing		
		chr	D. WHITING	6/6/95					
		appd	D. WHITING	6/6/95					
sheet index	revision sheet								

PRODUCT NUMBER
SEE TABLE

RECOMMENDED P. C. B. LAYOUT

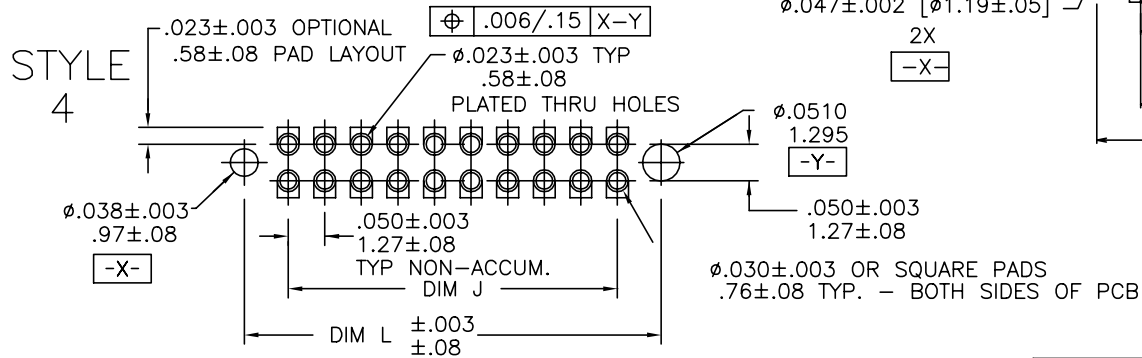
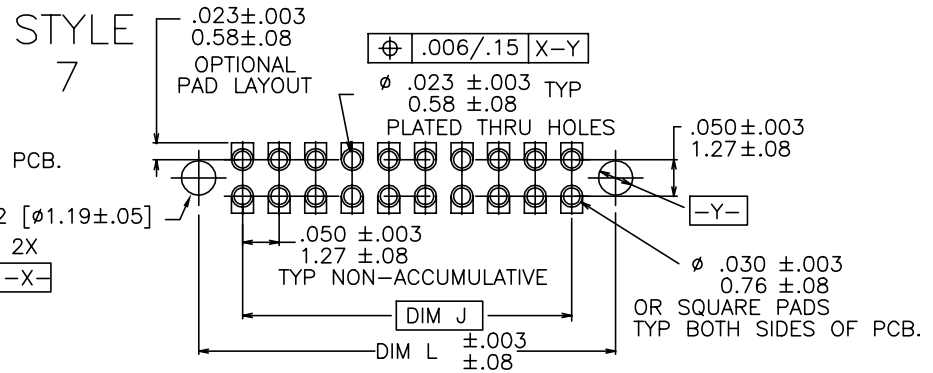
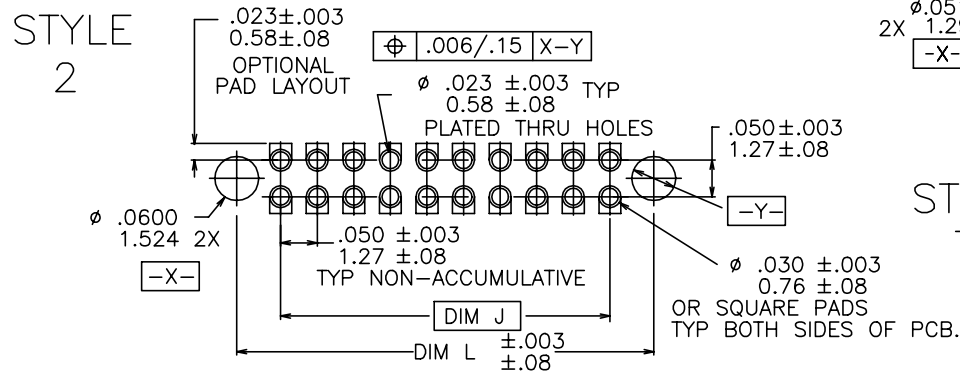
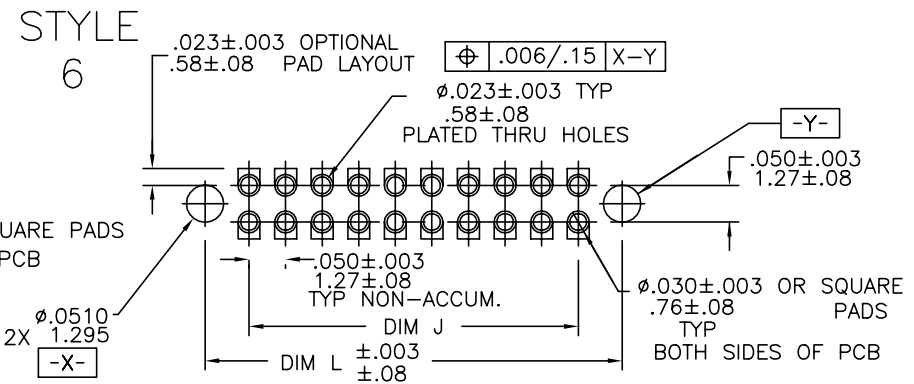
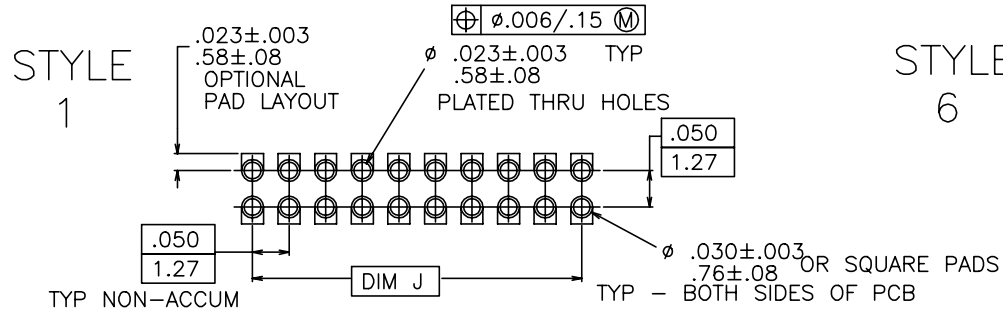

mat'l. code		surface	tolerance	projection	product family
-		ISO 1302	ISO 406 ISO 1101		RIBCAGE
ltr	ecn no	dr	date	title	
S				RIBCAGE III T/M VERT. HEADER ASS'Y	
tolerances unless otherwise specified				INCH/MM	dwg no
angles	linear	.XX±.01/0.3		sheet 4 of 6	size
		.XXX±.005/0.13		95776	A3
		.XXXX±.0020/0.051		type Product Customer Drawing	
dr	M. CORNMAN	6/6/95		FCI	
enr	D. WHITING	6/6/95			
chr	D. WHITING	6/6/95			
appd	D. WHITING	6/6/95			
sheet index	revision sheet				

PRODUCT NUMBER
SEE TABLE

RECOMMENDED P. C. B. LAYOUT

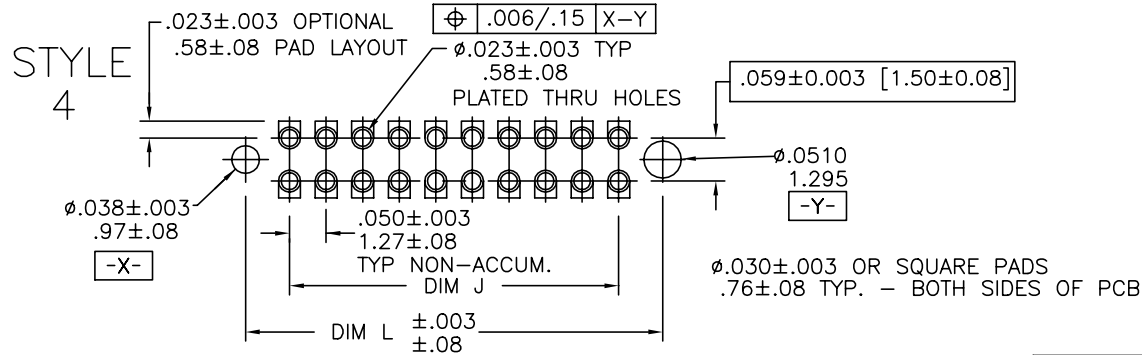
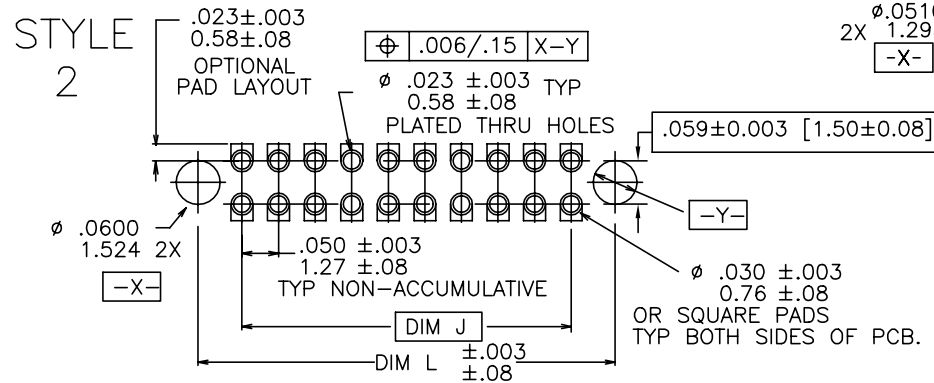
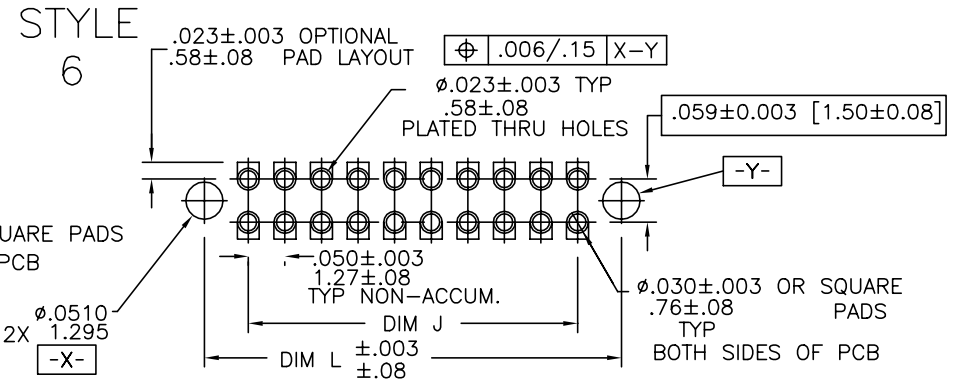
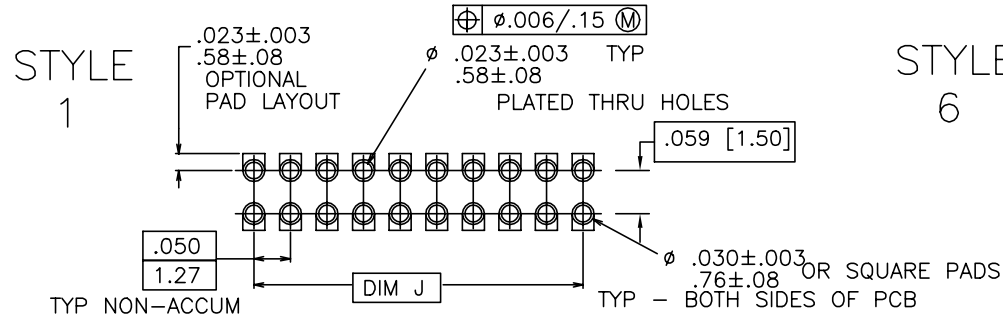

mat'l. code		surface	tolerance	projection	product family
-		ISO 1302	ISO 406 ISO 1101		RIBCAGE
ltr	ecn no	dr	date	title	
S				RIBCAGE III T/M VERT. HEADER ASS'Y	
tolerances unless otherwise specified				INCH/MM	sheet 5 of 6
angles	linear			scale 4:1	size
					A3
dr	M. CORNMAN	6/6/95			type Product Customer Drawing
enrg	D. WHITING	6/6/95			
chr	D. WHITING	6/6/95			
appd	D. WHITING	6/6/95			
sheet index	revision sheet				

PDM: Rev:S

STATUS: Released

Printed: May 15, 2010

PRODUCT NO. NOTE 1,7	DIM N SOLDER TAIL LENGTH	DIM P HEIGHT ABOVE BOARD (REF)	DIM R SOLDER TAIL SPREAD	HOLDDOWN STYLE
72449-1XX	.090/2.29	.221/5.63	.050/1.27	2
72450-1XX	.075/1.91	.293/7.44		2
72451-1XX	.115/2.92	.221/5.63		2
72452-1XX	.115/2.92	.221/5.63		6
73541-1XX	.075/1.91	.293/7.44		1
73543-1XX	.090/2.29	.359/9.12		1
87407-1XX	.090/2.29	.221/5.63		1
87850-1XX	.075/1.91			2
87851-1XX	.075/1.91			6
88550-1XX	.135/3.43			2
89289-1XX	.075/1.91			1
89465-1XX	.115/2.92			1
93149-1XX	.075/1.91			4
98382-1XX	.090/2.29	.221/5.63		7
98383-1XX	.090/2.29	.293/7.44		1
98384-1XX	.090/2.29	.293/7.44		7
98385-1XX	.090/2.29	.359/9.12	.050/1.27	7

PRODUCT NO. NOTE 1,7	DIM N SOLDER TAIL LENGTH	DIM P HEIGHT ABOVE BOARD (REF)	DIM R SOLDER TAIL SPREAD	HOLDDOWN STYLE
87400-1XX	.075/1.91	.221/5.63	.059/1.50	2
87405-1XX	.075/1.91			1
87405-2XX	.090/2.29			1
87406-1XX	.075/1.91			6
87406-2XX	.100/2.54			6
87410-1XX	.090/2.29	.221/5.63		2
87411-1XX	.075/1.91	.293/7.44		2
87412-1XX	.115/2.92	.221/5.63		2
89297-1XX	.115/2.92	.221/5.63	.059/1.50	6

NOTES:

- ① XXXXX-XXXLF
 - └ LEAD FREE OPTION (NOTE 7,8)
 - └ NUMBER OF POSITIONS (NOTE 2)
- ② NUMBER OF POSITIONS = 05 THRU 50 IN 5 POS INCREMENTS.
(EXAMPLE: 105=10 POS., 110=20 POS. ETC.)
- ③ REQUIRED ON -X40,-X45 & -X50 POSITION PARTS ONLY.
- 4. PACKAGE PER BUS-14-179.
- 5. HOUSING MATERIAL:
GLASS FILLED THERMOPLASTIC FLAME RETARDANT
PER UL 94V-0.
COLOR: NATURAL
- 6. TERMINAL PLATING:
30u"/.76u MIN HARD Au OVER 50u"/1.27u Ni ON
CONTACT ZONES.
100u"/2.54u MIN Sn OVER 50u"/1.27u Ni IN
SOLDERING ZONES.
- ⑦ ADD "LF" SUFFIX AT THE END OF PART NUMBER FOR
LEAD FREE OPTION.

- 8. THIS PRODUCT MEETS EUROPEAN UNION DIRECTIVES AND OTHER
COUNTRY REGULATION AS DESCRIBED IN GS-22-008.
- 9. THE HOUSING WILL WITHSTAND EXPOSURE TO 260°C PEAK TEMPERATURE
FOR 15 SECONDS IN A WAVE SOLDER APPLICATION WITH A 1.5mm
MINIMUM THICK CIRCUIT BOARD. SEE APPLICATION NOTES/PROCEDURES
IF THEY ARE AVAILABLE.

- ⑩ MOLDING FLOW RESTRICTOR QUANTITY AND LOCATION IS
MANUFACTURING OPTION.
- ⑪ VACUUM CAP SLOT REQUIRED ON ALL SIZES, SLOT MAY
BE LOCATED ON OPPOSITE SIDE FOR 2 X 5.

mat'l. code		surface		tolerance		projection		product family	
-		ISO 1302		ISO 406 ISO 1101				RIBCAGE	
ltr	ecn no	dr	date	tolerances unless otherwise specified		INCH/MM		title	
S				angles	linear	.XX±.01/0.3 .XXX±.005/0.13 .XXXX±.0020/0.051		RIBCAGE III T/M VERT. HEADER ASS'Y	
				0'±2'		scale 4:1		dwg no	
				dr	M. CORNMAN	6/6/95		sheet 6 of 6	
				engr	D. WHITING	6/6/95		size	
				chr	D. WHITING	6/6/95		A3	
				appd	D. WHITING	6/6/95		type	
sheet		revision							
index		sheet							