



CD4024BM/CD4024BC

7-Stage Ripple Carry Binary Counter

General Description

The CD4024BM/CD4024BC is a 7-stage ripple-carry binary counter. Buffered outputs are externally available from stages 1 through 7. The counter is reset to its logical "0" stage by a logical "1" on the reset input. The counter is advanced one count on the negative transition of each clock pulse.

Features

- Wide supply voltage range 3.0V to 15V
- High noise immunity 0.45 V_{DD} (typ.)
- Low power TTL compatibility Fan out of 2 driving 74L or 1 driving 74LS
- High speed 12 MHz (typ.)
- input pulse rate V_{DD} - V_{SS} = 10V
- Fully static operation

Connection Diagram

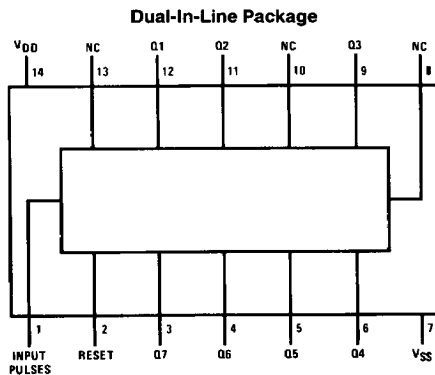

Top View

TL/F/5957-1

Order Number CD4024B*

*Please look into Section 8, Appendix D for availability of various package types.

Schematic Diagrams

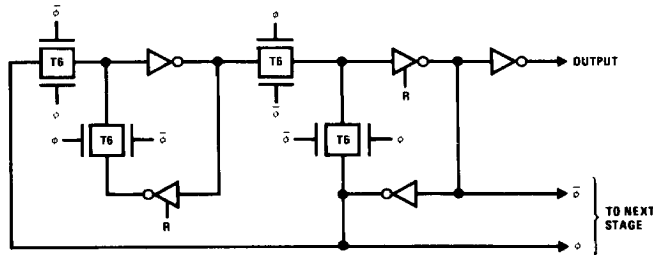

TL/F/5957-3

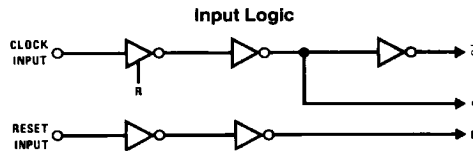

Flip-flop logic (1 of 7 identical stages).

TL/F/5957-4

Absolute Maximum Ratings (Notes 1 & 2)

If Military/Aerospace specified devices are required, contact the National Semiconductor Sales Office/Distributors for availability and specifications.

DC Supply Voltage (V_{DD})	-0.5 to +18 V_{DC}
Input Voltage (V_{IN})	-0.5 to V_{DD} + 0.5 V_{DC}
Storage Temperature Range (T_S)	-65°C to +150°C
Power Dissipation (P_D)	
Dual-In-Line	700 mW
Small Outline	500 mW
Lead Temp. (Soldering, 10 sec.) (T_L)	260°C

Recommended Operating Conditions (Note 2)

DC Supply Voltage (V_{DD})	+3 to +15 V_{DC}
Input Voltage (V_{IN})	0 to V_{DD} V_{DC}
Operating Temperature Range (T_A)	
CD4024BM	-55°C to +125°C
CD4024BC	-40°C to +85°C

DC Electrical Characteristics CD4024BM (Note 2)

Symbol	Parameter	Conditions	-55°C		+25°C			+125°C		Units
			Min	Max	Min	Typ	Max	Min	Max	
I_{DD}	Quiescent Device Current	$V_{DD} = 5V$ $V_{DD} = 10V$ $V_{DD} = 15V$		5 10 20		0.3 0.5 0.7	5 10 20		150 300 600	μA μA μA
V_{OL}	Low Level Output Voltage	$ I_O < 1 \mu A$ $V_{DD} = 5V$ $V_{DD} = 10V$ $V_{DD} = 15V$		0.05 0.05 0.05		0 0 0	0.05 0.05 0.05		0.05 0.05 0.05	V V V
V_{OH}	High Level Output Voltage	$ I_O < 1 \mu A$ $V_{DD} = 5V$ $V_{DD} = 10V$ $V_{DD} = 15V$	4.95 9.95 14.95		4.95 9.95 14.95	5 10 15		4.95 9.95 14.95		V V V
V_{IL}	Low Level Input Voltage	$ I_O < 1 \mu A$ $V_{DD} = 5V, V_O = 0.5V$ or 4.5V $V_{DD} = 10V, V_O = 1.0V$ or 9.0V $V_{DD} = 15V, V_O = 1.5V$ or 13.5V		1.5 3.0 4.0		2 4 6	1.5 3.0 4.0		1.5 3.0 4.0	V V V
V_{IH}	High Level Input Voltage	$ I_O < 1 \mu A$ $V_{DD} = 5V, V_O = 0.5V$ or 4.5V $V_{DD} = 10V, V_O = 1.0V$ or 9.0V $V_{DD} = 15V, V_O = 1.5V$ or 13.5V	3.5 7.0 11.0		3.5 7.0 11.0	3 6 9		3.5 7.0 11.0		V V V
I_{OL}	Low Level Output Current (Note 3)	$V_{DD} = 5V, V_O = 0.4V$ $V_{DD} = 10V, V_O = 0.5V$ $V_{DD} = 15V, V_O = 1.5V$	0.64 1.6 4.2		0.51 1.3 3.4	0.88 2.25 8.8		0.36 0.9 2.4		mA mA mA
I_{OH}	High Level Output Current (Note 3)	$V_{DD} = 5V, V_O = 4.6V$ $V_{DD} = 10V, V_O = 9.5V$ $V_{DD} = 15V, V_O = 13.5V$	-0.64 -1.6 -4.2		-0.51 -1.3 -3.4	-0.88 -2.25 -8.8		-0.36 -0.9 -2.4		mA mA mA
I_{IN}	Input Current	$V_{DD} = 15V, V_{IN} = 0V$ $V_{DD} = 15V, V_{IN} = 15V$		-0.10 0.10		-10 ⁻⁵ 10 ⁻⁵	-0.10 0.10		-1.0 1.0	μA μA

DC Electrical Characteristics CD4024BC (Note 2)

Symbol	Parameter	Conditions	-40°C		+25°C			+85°C		Units
			Min	Max	Min	Typ	Max	Min	Max	
I_{DD}	Quiescent Device Current	$V_{DD} = 5V$ $V_{DD} = 10V$ $V_{DD} = 15V$		20 40 60		0.3 0.5 0.7	20 40 80		150 300 600	μA μA μA
V_{OL}	Low Level Output Voltage	$ I_O < 1 \mu A$ $V_{DD} = 5V$ $V_{DD} = 10V$ $V_{DD} = 15V$		0.05 0.05 0.05		0 0 0	0.05 0.05 0.05		0.05 0.05 0.05	V V V
V_{OH}	High Level Output Voltage	$ I_O < 1 \mu A$ $V_{DD} = 5V$ $V_{DD} = 10V$ $V_{DD} = 15V$	4.95 9.95 14.95		4.95 9.95 14.95	5 10 15		4.95 9.95 14.95		V V V

DC Electrical Characteristics CD4024BC (Note 2) (Continued)

Symbol	Parameter	Conditions	-40°C		+25°C			+85°C		Units
			Min	Max	Min	Typ	Max	Min	Max	
V _{IL}	Low Level Input Voltage	I _O < 1 μA V _{DD} = 5V, V _O = 0.5V or 4.5V V _{DD} = 10V, V _O = 1.0V or 9.0V V _{DD} = 15V, V _O = 1.5V or 13.5V		1.5		2	1.5		1.5	V
				3.0		4	3.0		3.0	V
				4.0		6	4.0		4.0	V
V _{IH}	High Level Input Voltage	I _O < 1 μA V _{DD} = 5V, V _O = 0.5V or 4.5V V _{DD} = 10V, V _O = 1.0V or 9.0V V _{DD} = 15V, V _O = 1.5V or 13.5V	3.5		3.5	3		3.5		V
			7.0		7.0	6		7.0		V
			11.0		11.0	9		11.0		V
I _{OL}	Low Level Output Current (Note 3)	V _{DD} = 5V, V _O = 0.4V V _{DD} = 10V, V _O = 0.5V V _{DD} = 15V, V _O = 1.5V	0.52		0.44	0.88		0.36		mA
			1.3		1.1	2.25		0.9		mA
			3.6		3.0	8.8		2.4		mA
I _{OH}	High Level Output Current (Note 3)	V _{DD} = 5V, V _O = 4.6V V _{DD} = 10V, V _O = 9.5V V _{DD} = 15V, V _O = 13.5V	-0.52		-0.44	-0.88		-0.36		mA
			-1.3		-1.1	-2.25		-0.9		mA
			-3.6		-3.0	-8.8		-2.4		mA
I _{IN}	Input Current	V _{DD} = 15V, V _{IN} = 0V V _{DD} = 15V, V _{IN} = 15V		-0.30 0.30		-10 ⁻⁵ 10 ⁻⁵	-0.30 0.30		-1.0 1.0	μA μA

AC Electrical Characteristics*T_A = 25°C, C_L = 50 pF, R_L = 200 k, t_r and t_f = 20 ns unless otherwise specified

Symbol	Parameter	Conditions	Min	Typ	Max	Units
t _{PHL} , t _{PLH}	Propagation Delay Time to Q1 Output	V _{DD} = 5V		185	350	ns
		V _{DD} = 10V		85	125	ns
		V _{DD} = 15V		70	100	ns
t _{THL} , t _{TLH}	Transition Time	V _{DD} = 5V		100	200	ns
		V _{DD} = 10V		50	100	ns
		V _{DD} = 15V		40	80	ns
t _{WL} , t _{WH}	Minimum Input Pulse Width	V _{DD} = 5V		75	200	ns
		V _{DD} = 10V		40	110	ns
		V _{DD} = 15V		35	90	ns
t _{RCL} , t _{FCL}	Input Rise and Fall Time	V _{DD} = 5V			15	μs
		V _{DD} = 10V			10	μs
		V _{DD} = 15V			8	μs
f _{CL}	Maximum Input Pulse Frequency	V _{DD} = 5V	1.5	5		MHz
		V _{DD} = 10V	4	12		MHz
		V _{DD} = 15V	5	15		MHz
t _{PHL}	Reset Propagation Delay Time	V _{DD} = 5V		185	350	ns
		V _{DD} = 10V		85	125	ns
		V _{DD} = 15V		70	100	ns
t _{WH}	Reset Minimum Pulse Width	V _{DD} = 5V		185	350	ns
		V _{DD} = 10V		85	125	ns
		V _{DD} = 15V		70	100	ns
C _{IN}	Input Capacitance (Note 4)	Any Input		5	7.5	pF

*AC Parameters are guaranteed by DC correlated testing.

Note 1: "Absolute Maximum Ratings" are those values beyond which the safety of the device cannot be guaranteed, they are not meant to imply that the devices should be operated at these limits. The table of "Recommended Operating Conditions" and "Electrical Characteristics" provides conditions for actual device operation.

Note 2: V_{SS} = 0V unless otherwise specified.

Note 3: I_{OH} and I_{OL} are tested one output at a time.

Note 4: Capacitance is guaranteed by periodic testing.

Logic Diagram

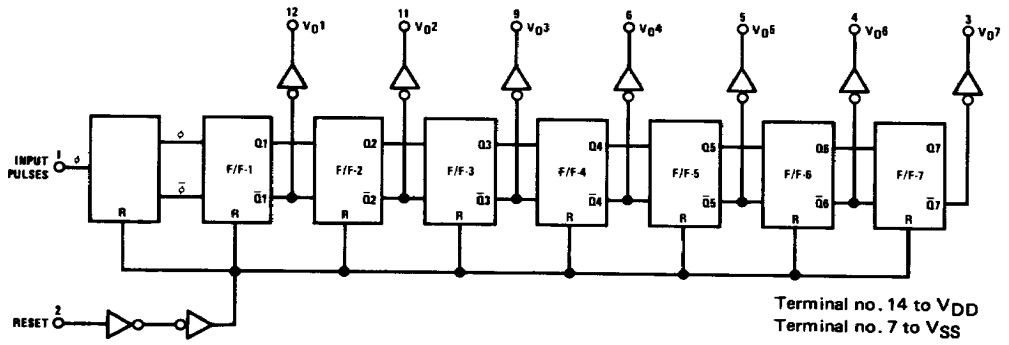

TL/F/5957-2