



MJE13005D

Preliminary

NPN SILICON TRANSISTOR

**HIGH VOLTAGE
FAST-SWITCHING NPN POWER
TRANSISTOR**

■ DESCRIPTION

The UTC **MJE13005D** is a high voltage fast-switching NPN power transistor. It is characterized by high breakdown voltage, high current capability, high switching speed and high reliability.

The UTC **MJE13005D** is intended to be used in energy-saving light, electronic ballast, high frequency switching power supply, high frequency power transform or common power amplifier, etc.

■ FEATURES

- * High Breakdown Voltage
- * High Current Capability
- * High Switching Speed
- * High Reliability
- * RoHS-Compliant Product

■ INTERNAL SCHEMATIC DIAGRAM

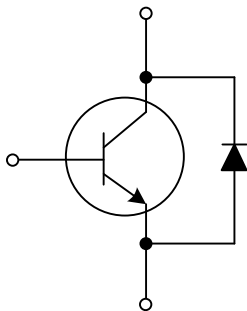

■ ORDERING INFORMATION

Ordering Number		Package	Pin Assignment			Packing
Lead Free	Halogen Free		1	2	3	
MJE13005DL-TA3-T	MJE13005DG-TA3-T	TO-220	B	C	E	Tube

<p>MJE13005DL-TA3-T</p> <ul style="list-style-type: none"> (1) Packing Type (2) Package Type (3) Lead Free 	<ul style="list-style-type: none"> (1) T: Tube (2) TA3: TO-220 (3) G: Halogen Free, L: Lead Free
---	---

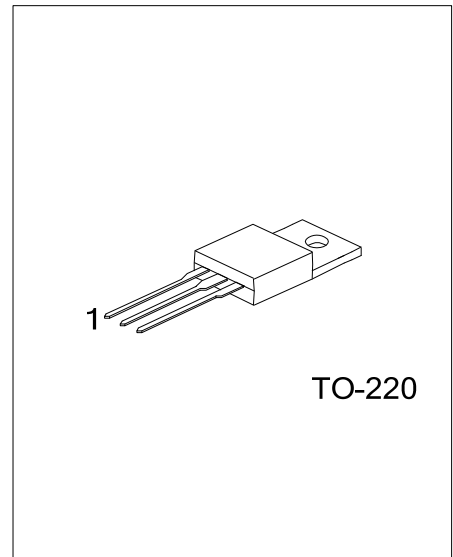

■ ABSOLUTE MAXIMUM RATING ($T_C=25^\circ\text{C}$)

PARAMETER		SYMBOL	RATING	UNIT
Collector- Emitter Voltage ($V_{BE}=0$)		V_{CES}	700	V
Collector-Emitter Voltage ($I_B=0$)		V_{CEO}	400	V
Emitter-Base Voltage		V_{EBO}	9	V
Collector Current	DC	I_C	4	A
	Pulse	I_{CP}	8	A
Base Current	DC	I_B	2	A
	Pulse	I_{BP}	4	A
Power Dissipation		P_D	75	W
Storage Temperature		T_{STG}	-55 ~ +150	$^\circ\text{C}$

Notes: 1. Absolute maximum ratings are those values beyond which the device could be permanently damaged.

Absolute maximum ratings are stress ratings only and functional device operation is not implied.

2. Pulse Test: Pulse Width = 5.0 ms, Duty Cycle < 10%.

■ THERMAL DATA

PARAMETER	SYMBOL	RATING	UNIT
Junction to Ambient	θ_{JA}	62.5	$^\circ\text{C/W}$
Junction to Case	θ_{JC}	1.67	$^\circ\text{C/W}$

■ ELECTRICAL CHARACTERISTICS

PARAMETER		SYMBOL	TEST CONDITIONS	MIN	TYP	MAX	UNIT
Collector-Emitter Breakdown Voltage		BV_{CEO}	$I_C=10\text{mA}, I_B=0$	400			V
Collector -Base Breakdown Voltage		BV_{CBO}	$I_C=1\text{mA}, I_B=0$	700			V
Emitter-Base Breakdown Voltage		BV_{EBO}	$I_E=1\text{mA}, I_C=0$	9			V
Collect Cut-off Current		I_{CBO}	$V_{CB}=700\text{V}, I_E=0$			100	μA
Collect Cut-off Current		I_{CEO}	$V_{CE}=400\text{V}, I_B=0$			50	μA
Emitter Cut-off Current		I_{EBO}	$V_{EB}=9\text{V}, I_C=0$			10	μA
DC Current Gain		h_{FE1}	$V_{CE}=5\text{V}, I_C=500\text{mA}$	8		50	
		h_{FE2}	$V_{CE}=5\text{V}, I_C=2\text{A}$	5			
Collector-Emitter Saturation Voltage		V_{CE}	$I_C=1\text{A}, I_B=0.2\text{A}$			0.5	V
			$I_C=2\text{A}, I_B=0.5\text{A}$			0.6	
			$I_C=4\text{A}, I_B=1\text{A}$			1	
			$I_C=2\text{A}, I_B=0.5\text{A}, T_C=100^\circ\text{C}$			1	
Base-Emitter Saturation Voltage		$V_{BE(SAT)}$	$I_C=2\text{A}, I_B=0.5\text{A}$			1.6	V
Resistive Load	Fall Time	t_F	$V_{CC}=24\text{V}, I_C=2\text{A}, I_{B1}=-I_{B2}=0.4\text{A}$			0.7	μs
	Storage Time	t_S				4	μs
Current Gain Bandwidth Product		f_T	$V_{CE}=10\text{V}, I_C=0.5\text{A}$	4			MHz

UTC assumes no responsibility for equipment failures that result from using products at values that exceed, even momentarily, rated values (such as maximum ratings, operating condition ranges, or other parameters) listed in products specifications of any and all UTC products described or contained herein. UTC products are not designed for use in life support appliances, devices or systems where malfunction of these products can be reasonably expected to result in personal injury. Reproduction in whole or in part is prohibited without the prior written consent of the copyright owner. The information presented in this document does not form part of any quotation or contract, is believed to be accurate and reliable and may be changed without notice.