

ELM99xxxA LOW SATURATION VOLTAGE REGULATOR

■ GENERAL DESCRIPTION

ELM99xxxA series is CMOS voltage regulator providing large current. It consists of devices including reference voltage source, error amplifier, low resistance output transistor, short-circuit protection circuit, output voltage setting resistor, chip-enable circuit. Output voltage is fixed internally with high accuracy. ELM99xxxA provides excellent characteristics, such as small input-output voltage difference due to low resistance output transistor, high load stability due to high gain error amplifier.

The chip-enable function is available in three selections, no-chip enable function, active-low ("L" active) and active-high ("H" active).

The package is SOT-89-3 or SOT-89-5. SOT-89-5 is used for chip enable version.

■ FEATURES

- Maximum output current : 300mA (Internal current limiter operates in case load current exceeds 300mA.)
- High accuracy of output voltage : $\pm 2.0\%$
- Small input-output voltage differential : TYP. 140mV (ELM9930xA IOUT=40mA)
- Low stand-by current consumption : TYP. 0.1 μ A (ELM99xx3A)
- High load stability : TYP. 5mV ($1\text{mA} \leq I_{\text{out}} \leq 100\text{mA}$)
- High input stability : TYP. 0.15%/V (ELM9930xA IOUT=40mA)
- Output voltage range : 2.0V ~ 6.0V (0.1V steps)
- Short-circuit current limiter : TYP. 70mA (VOUT=0V)
- Chip-enable pin available : "L"active ELM99xx2A, "H"active ELM99xx3A

■ APPLICATION

- Cellular telephones
- Laptop and notebook computers
- Reference voltage sources
- PCMCIA cards
- Palmtops
- cameras and video recorders
- Battery-operated devices

■ PIN CONFIGURATION

1.ELM99xx1A

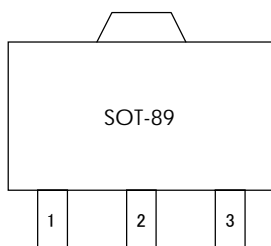

(TOP VIEW)

SOT-89	
Pin No.	Pin Name
1	VSS
2	VIN
3	VOUT

2.ELM99xx2A

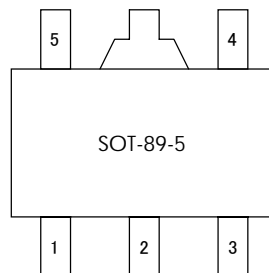

(TOP VIEW)

SOT-89-5	
Pin No.	Pin Name
1	VSS
2	VIN
3	VOUT
4	NC
5	$\overline{\text{CE}}$

3.ELM99xx3A

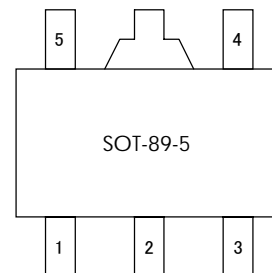

(TOP VIEW)

SOT-89-5	
Pin No.	Pin Name
1	VSS
2	VIN
3	VOUT
4	NC
5	CE

LOW SATURATION VOLTAGE REGULATOR ELM99xxxA

SELECTION GUIDE

Symbol		
a, b	Output Voltage	Ex 27 : VOUT = 2.7V 30 : VOUT = 3.0V 33 : VOUT = 3.3V 50 : VOUT = 5.0V
c	CE Selection	1 : _____ 2 : \overline{CE} = "L" active 3 : CE = "H" active
d	Product Version	A : A Version

ELM99 x x x A
 ↑ ↑ ↑ ↑
 a b c d

MARKING

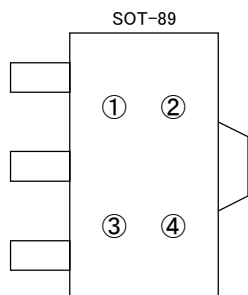

ELM99xx1A

① : Represents the integer digit of the Output Voltage

Symbol	Output Voltage	Symbol	Output Voltage
A	2.*V	D	5.*V
B	3.*V	E	6.*V
C	4.*V		

② : Represents the decimal digit of the Output Voltage

Symbol	Output Voltage	Symbol	Output Voltage
A	*.0V	F	*.5V
B	*.1V	G	*.6V
C	*.2V	H	*.7V
D	*.3V	J	*.8V
E	*.4V	K	*.9V

③ : Represents the assembly lot number
A ~ Z repeated (I,O,X excepted)

④ : Represents the assembly lot number
0 ~ 9 repeated

LOW SATURATION VOLTAGE REGULATOR ELM99xxxA

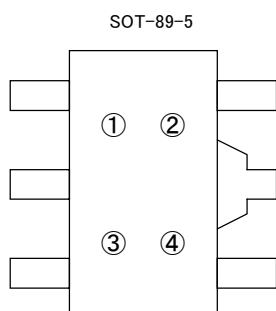

ELM99xx2A

① : Represents the integer digit of the Output Voltage

Symbol	Output Voltage	Symbol	Output Voltage
F	2.*V	J	5.*V
G	3.*V	K	6.*V
H	4.*V		

② : Represents the decimal digit of the Output Voltage

Symbol	Output Voltage	Symbol	Output Voltage
A	*.0V	F	*.5V
B	*.1V	G	*.6V
C	*.2V	H	*.7V
D	*.3V	J	*.8V
E	*.4V	K	*.9V

③ : Represents the assembly lot number

A ~ Z repeated (I,O,X excepted)

④ : Represents the assembly lot number

0 ~ 9 repeated

ELM99xx3A

① : Represents the integer digit of the Output Voltage

Symbol	Output Voltage	Symbol	Output Voltage
L	2.*V	P	5.*V
M	3.*V	Q	6.*V
N	4.*V		

② : Represents the decimal digit of the Output Voltage

Symbol	Output Voltage	Symbol	Output Voltage
A	*.0V	F	*.5V
B	*.1V	G	*.6V
C	*.2V	H	*.7V
D	*.3V	J	*.8V
E	*.4V	K	*.9V

③ : Represents the assembly lot number

A ~ Z repeated (I,O,X excepted)

④ : Represents the assembly lot number

0 ~ 9 repeated

LOW SATURATION VOLTAGE REGULATOR ELM99xxxA

■ BLOCK DIAGRAM

ELM99xx1A

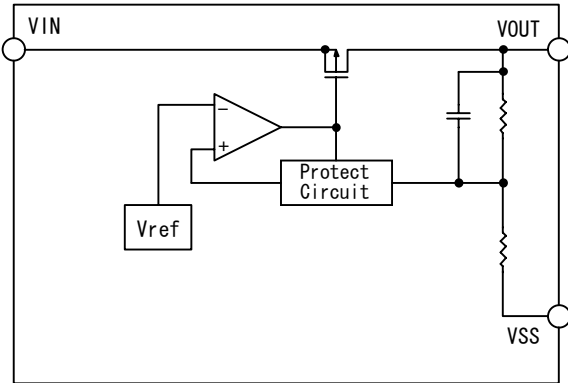

ELM99xx2A, ELM99xx3A

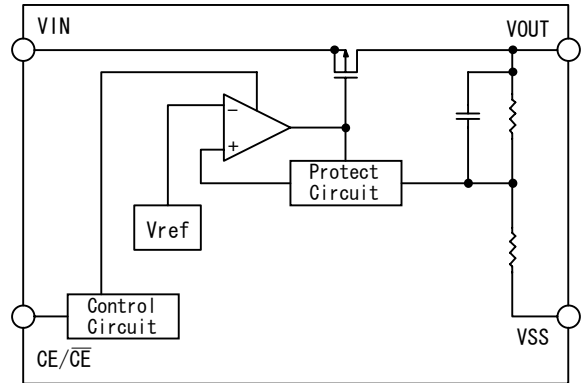

* \overline{CE} : ELM99xx2A, CE : ELM99xx3A

■ STANDARD CIRCUIT

ELM99xx1A

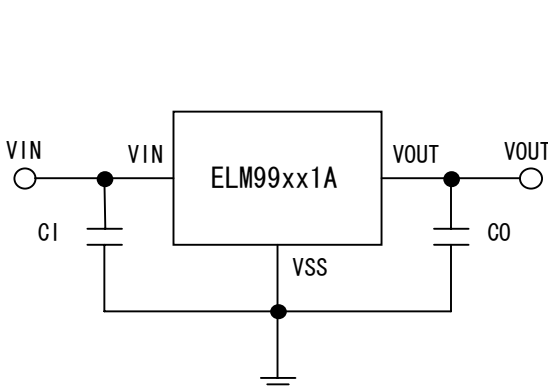

ELM99xx2A, ELM99xx3A

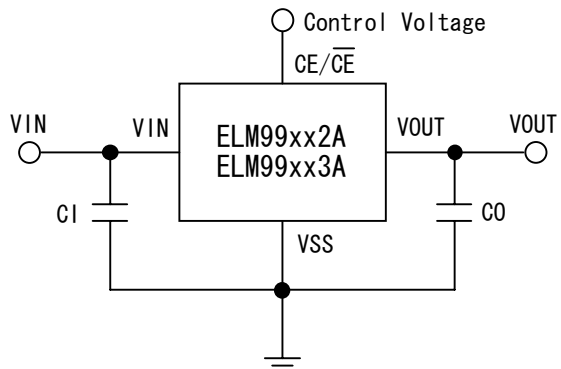

* \overline{CE} : ELM99xx2A, CE : ELM99xx3A

■ MAXIMUM ABSOLUTE RATINGS

(VSS=0V)

Parameter	Sym.	Limits	Units
Input Voltage	VIN	12	V
\overline{CE}/CE Input Voltage	VCE	VSS-0.3~VIN+0.3	V
Output Voltage	VOUT	VSS-0.3~VIN+0.3	V
Output Current	IOUT	500	mA
Power Dissipation	Pd	SOT-89	300
		SOT-89-5	500
Operating Temperature	Top	-30~+80	°C
Storage Temperature	Tstg	-40~+125	°C

* Output current must not exceed power dissipation specified in Maximum Absolute Ratings.

LOW SATURATION VOLTAGE REGULATOR ELM99xxxA

■ ELECTRICAL CHARACTERISTICS

ELM99271A

(Top=25°C)

Parameter	Symbol	Conditions	Min.	Typ.	Max.	Units
Output Voltage	VOUT	VIN=3.7V, IOU=40mA	2.646	2.700	2.754	V
Output Current	IOU	VIN=3.7V, Lower by 0.1V than VOUT	150	260		mA
Load Stability	$\frac{\Delta V_{OUT}}{\Delta I_{OUT}}$	VIN=3.7V 1mA ≤ IOU ≤ 100mA		5	15	mV
Input/Output Voltage Differential	Vdif	IOU=40mA		155	255	mV
Current Consumption	ISS	VIN=3.7V No-load		25	45	μA
Input Stability	$\frac{\Delta V_{OUT}}{\Delta V_{IN}}$	3.7V ≤ VIN ≤ 8.0V IOU=40mA		0.15	0.30	%/V
Input Voltage	VIN				8.0	V
Output Voltage Temp. Characteristics	$\frac{\Delta V_{OUT}}{\Delta T_{top}}$	VIN=3.7V, IOU=40mA -30°C ≤ Top ≤ +80°C		± 100		ppm/°C
Short-circuit Current	Ilim	VOUT=0V		70		mA

ELM99301A

(Top=25°C)

Parameter	Symbol	Conditions	Min.	Typ.	Max.	Units
Output Voltage	VOUT	VIN=4.0V, IOU=40mA	2.940	3.000	3.060	V
Output Current	IOU	VIN=4.0V, Lower by 0.1V than VOUT	160	290		mA
Load Stability	$\frac{\Delta V_{OUT}}{\Delta I_{OUT}}$	VIN=4.0V 1mA ≤ IOU ≤ 100mA		5	15	mV
Input/Output Voltage Differential	Vdif	IOU=40mA		140	220	mV
Current Consumption	ISS	VIN=4.0V No-load		25	45	μA
Input Stability	$\frac{\Delta V_{OUT}}{\Delta V_{IN}}$	4.0V ≤ VIN ≤ 8.0V IOU=40mA		0.15	0.30	%/V
Input Voltage	VIN				8.0	V
Output Voltage Temp. Characteristics	$\frac{\Delta V_{OUT}}{\Delta T_{top}}$	VIN=4.0V, IOU=40mA -30°C ≤ Top ≤ +80°C		± 100		ppm/°C
Short-circuit Current	Ilim	VOUT=0V		70		mA

LOW SATURATION VOLTAGE REGULATOR ELM99xxxA

ELM99331A

(Top=25°C)

Parameter	Symbol	Conditions	Min.	Typ.	Max.	Units
Output Voltage	VOUT	VIN=4.3V, IOU=40mA	3.234	3.300	3.366	V
Output Current	IOU	VIN=4.3V, Lower by 0.1V than VOUT	170	300		mA
Load Stability	$\frac{\Delta V_{OUT}}{\Delta I_{OUT}}$	VIN=4.3V 1mA ≤ IOU ≤ 100mA		5	15	mV
Input/Output Voltage Differential	Vdif	IOU=40mA		125	210	mV
Current Consumption	ISS	VIN=4.3V No-load		25	45	μA
Input Stability	$\frac{\Delta V_{OUT}}{\Delta V_{IN}}$	4.3V ≤ VIN ≤ 8.0V IOU=40mA		0.15	0.30	%/V
Input Voltage	VIN				8.0	V
Output Voltage Temp. Characteristics	$\frac{\Delta V_{OUT}}{\Delta T_{top}}$	VIN=4.3V, IOU=40mA -30°C ≤ Top ≤ +80°C		± 100		ppm/°C
Short-circuit Current	Ilim	VOUT=0V		70		mA

ELM99501A

(Top=25°C)

Parameter	Symbol	Conditions	Min.	Typ.	Max.	Units
Output Voltage	VOUT	VIN=6.0V, IOU=40mA	4.900	5.000	5.100	V
Output Current	IOU	VIN=6.0V, Lower by 0.1V than VOUT	200	330		mA
Load Stability	$\frac{\Delta V_{OUT}}{\Delta I_{OUT}}$	VIN=6.0V 1mA ≤ IOU ≤ 100mA		5	15	mV
Input/Output Voltage Differential	Vdif	IOU=40mA		105	170	mV
Current Consumption	ISS	VIN=6.0V No-load		30	55	μA
Input Stability	$\frac{\Delta V_{OUT}}{\Delta V_{IN}}$	6.0V ≤ VIN ≤ 8.0V IOU=40mA		0.15	0.30	%/V
Input Voltage	VIN				8.0	V
Output Voltage Temp. Characteristics	$\frac{\Delta V_{OUT}}{\Delta T_{top}}$	VIN=6.0V, IOU=40mA -30°C ≤ Top ≤ +80°C		± 100		ppm/°C
Short-circuit Current	Ilim	VOUT=0V		70		mA

LOW SATURATION VOLTAGE REGULATOR ELM99xxxA

ELM99272A

(Top=25°C)

Parameter	Symbol	Conditions	Min.	Typ.	Max.	Units
Output Voltage	VOUT	VIN=3.7V, IOU=40mA	2.646	2.700	2.754	V
Output Current	IOU	VIN=3.7V, Lower by 0.1V than VOUT	150	260		mA
Load Stability	$\frac{\Delta V_{OUT}}{\Delta I_{OUT}}$	VIN=3.7V 1mA ≤ IOU ≤ 100mA		5	15	mV
Input/Output Voltage Differential	Vdif	IOU=40mA		155	255	mV
Current Consumption	ISS	VIN=3.7V		25	45	μA
Stand-by Current Consumption	Istandby	VIN=VCE=3.7V		0.005	0.1	μA
Input Stability	$\frac{\Delta V_{OUT}}{\Delta V_{IN}}$	3.7V ≤ VIN ≤ 8.0V IOU=40mA		0.15	0.30	%/V
Input Voltage	VIN				8.0	V
Output Voltage Temp. Characteristics	$\frac{\Delta V_{OUT}}{\Delta T_{top}}$	VIN=3.7V, IOU=40mA -30°C ≤ Top ≤ +80°C		±100		ppm/°C
Short-circuit Current	Ilim	VOUT=0V		70		mA
\overline{CE} Input Voltage "H"	VCEH	VIN=8.0V	1.80		VIN	V
\overline{CE} Input Voltage "L"	VCEL	VIN=2.0V	0		0.25	V
\overline{CE} Input Current "H"	ICEH	VCE=VIN		0	0.2	μA
\overline{CE} Input Current "L"	ICEL	VCE=VSS	-1.5	-0.4		μA

ELM99302A

(Top=25°C)

Parameter	Symbol	Conditions	Min.	Typ.	Max.	Units
Output Voltage	VOUT	VIN=4.0V, IOU=40mA	2.940	3.000	3.060	V
Output Current	IOU	VIN=4.0V, Lower by 0.1V than VOUT	160	290		mA
Load Stability	$\frac{\Delta V_{OUT}}{\Delta I_{OUT}}$	VIN=4.0V 1mA ≤ IOU ≤ 100mA		5	15	mV
Input/Output Voltage Differential	Vdif	IOU=40mA		140	220	mV
Current Consumption	ISS	VIN=4.0V		25	45	μA
Stand-by Current Consumption	Istandby	VIN=VCE=4.0V		0.005	0.1	μA
Input Stability	$\frac{\Delta V_{OUT}}{\Delta V_{IN}}$	4.0V ≤ VIN ≤ 8.0V IOU=40mA		0.15	0.30	%/V
Input Voltage	VIN				8.0	V
Output Voltage Temp. Characteristics	$\frac{\Delta V_{OUT}}{\Delta T_{top}}$	VIN=4.0V, IOU=40mA -30°C ≤ Top ≤ +80°C		±100		ppm/°C
Short-circuit Current	Ilim	VOUT=0V		70		mA
\overline{CE} Input Voltage "H"	VCEH	VIN=8.0V	1.80		VIN	V
\overline{CE} Input Voltage "L"	VCEL	VIN=2.0V	0		0.25	V
\overline{CE} Input Current "H"	ICEH	VCE=VIN		0	0.2	μA
\overline{CE} Input Current "L"	ICEL	VCE=VSS	-1.5	-0.4		μA

LOW SATURATION VOLTAGE REGULATOR ELM99xxxA

ELM99332A

(Top=25°C)

Parameter	Symbol	Conditions	Min.	Typ.	Max.	Units
Output Voltage	VOUT	VIN=4.3V, IOU=40mA	3.234	3.300	3.366	V
Output Current	IOU	VIN=4.3V, Lower by 0.1V than VOUT	170	300		mA
Load Stability	$\frac{\Delta V_{OUT}}{\Delta I_{OUT}}$	VIN=4.3V 1mA ≤ IOU ≤ 100mA		5	15	mV
Input/Output Voltage Differential	Vdif	IOU=40mA		125	210	mV
Current Consumption	ISS	VIN=4.3V		25	45	μA
Stand-by Current Consumption	Istandby	VIN=VCE=4.3V		0.005	0.1	μA
Input Stability	$\frac{\Delta V_{OUT}}{\Delta V_{IN}}$	4.3V ≤ VIN ≤ 8.0V IOU=40mA		0.15	0.30	%/V
Input Voltage	VIN				8.0	V
Output Voltage Temp. Characteristics	$\frac{\Delta V_{OUT}}{\Delta T_{top}}$	VIN=4.3V, IOU=40mA -30°C ≤ Top ≤ +80°C		±100		ppm/°C
Short-circuit Current	Ilim	VOUT=0V		70		mA
\overline{CE} Input Voltage "H"	VCEH	VIN=8.0V	1.80		VIN	V
\overline{CE} Input Voltage "L"	VCEL	VIN=2.0V	0		0.25	V
\overline{CE} Input Current "H"	ICEH	VCE=VIN		0	0.2	μA
\overline{CE} Input Current "L"	ICEL	VCE=VSS	-1.5	-0.4		μA

ELM99502A

(Top=25°C)

Parameter	Symbol	Conditions	Min.	Typ.	Max.	Units
Output Voltage	VOUT	VIN=6.0V, IOU=40mA	4.900	5.000	5.100	V
Output Current	IOU	VIN=6.0V, Lower by 0.1V than VOUT	200	330		mA
Load Stability	$\frac{\Delta V_{OUT}}{\Delta I_{OUT}}$	VIN=6.0V 1mA ≤ IOU ≤ 100mA		5	15	mV
Input/Output Voltage Differential	Vdif	IOU=40mA		105	170	mV
Current Consumption	ISS	VIN=6.0V		30	55	μA
Stand-by Current Consumption	Istandby	VIN=VCE=6.0V		0.005	0.1	μA
Input Stability	$\frac{\Delta V_{OUT}}{\Delta V_{IN}}$	6.0V ≤ VIN ≤ 8.0V IOU=40mA		0.15	0.30	%/V
Input Voltage	VIN				8.0	V
Output Voltage Temp. Characteristics	$\frac{\Delta V_{OUT}}{\Delta T_{top}}$	VIN=6.0V, IOU=40mA -30°C ≤ Top ≤ +80°C		±100		ppm/°C
Short-circuit Current	Ilim	VOUT=0V		70		mA
\overline{CE} Input Voltage "H"	VCEH	VIN=8.0V	1.80		VIN	V
\overline{CE} Input Voltage "L"	VCEL	VIN=2.0V	0		0.25	V
\overline{CE} Input Current "H"	ICEH	VCE=VIN		0	0.2	μA
\overline{CE} Input Current "L"	ICEL	VCE=VSS	-1.5	-0.4		μA

LOW SATURATION VOLTAGE REGULATOR ELM99xxxA

ELM99273A

(Top=25°C)

Parameter	Symbol	Conditions	Min.	Typ.	Max.	Units
Output Voltage	VOUT	VIN=3.7V, IOU=40mA	2.646	2.700	2.754	V
Output Current	IOU	VIN=3.7V, Lower by 0.1V than VOUT	150	260		mA
Load Stability	$\frac{\Delta V_{OUT}}{\Delta I_{OUT}}$	VIN=3.7V 1mA ≤ IOU ≤ 100mA		5	15	mV
Input/Output Voltage Differential	Vdif	IOU=40mA		155	255	mV
Current Consumption	ISS	VIN=3.7V		25	45	μA
Stand-by Current Consumption	Istandby	VIN=3.7V, VCE=VSS		0.1	0.5	μA
Input Stability	$\frac{\Delta V_{OUT}}{\Delta V_{IN}}$	3.7V ≤ VIN ≤ 8.0V IOU=40mA		0.15	0.30	%/V
Input Voltage	VIN				8.0	V
Output Voltage Temp. Characteristics	$\frac{\Delta V_{OUT}}{\Delta T_{top}}$	VIN=3.7V, IOU=40mA -30°C ≤ Top ≤ +80°C		±100		ppm/°C
Short-circuit Current	Ilim	VOUT=0V		70		mA
CE Input Voltage "H"	VCEH	VIN=8.0V	1.80		VIN	V
CE Input Voltage "L"	VCEL	VIN=2.0V	0		0.25	V
CE Input Current "H"	ICEH	VCE=VIN		0.4	1.5	μA
CE Input Current "L"	ICEL	VCE=VSS	-0.2	0		μA

ELM99303A

(Top=25°C)

Parameter	Symbol	Conditions	Min.	Typ.	Max.	Units
Output Voltage	VOUT	VIN=4.0V, IOU=40mA	2.940	3.000	3.060	V
Output Current	IOU	VIN=4.0V, Lower by 0.1V than VOUT	160	290		mA
Load Stability	$\frac{\Delta V_{OUT}}{\Delta I_{OUT}}$	VIN=4.0V 1mA ≤ IOU ≤ 100mA		5	15	mV
Input/Output Voltage Differential	Vdif	IOU=40mA		140	220	mV
Current Consumption	ISS	VIN=4.0V		25	45	μA
Stand-by Current Consumption	Istandby	VIN=4.0V, VCE=VSS		0.1	0.5	μA
Input Stability	$\frac{\Delta V_{OUT}}{\Delta V_{IN}}$	4.0V ≤ VIN ≤ 8.0V IOU=40mA		0.15	0.30	%/V
Input Voltage	VIN				8.0	V
Output Voltage Temp. Characteristics	$\frac{\Delta V_{OUT}}{\Delta T_{top}}$	VIN=4.0V, IOU=40mA -30°C ≤ Top ≤ +80°C		±100		ppm/°C
Short-circuit Current	Ilim	VOUT=0V		70		mA
CE Input Voltage "H"	VCEH	VIN=8.0V	1.80		VIN	V
CE Input Voltage "L"	VCEL	VIN=2.0V	0		0.25	V
CE Input Current "H"	ICEH	VCE=VIN		0.4	1.5	μA
CE Input Current "L"	ICEL	VCE=VSS	-0.2	0		μA

LOW SATURATION VOLTAGE REGULATOR ELM99xxxA

ELM99333A

(Top=25°C)

Parameter	Symbol	Conditions	Min.	Typ.	Max.	Units
Output Voltage	VOUT	VIN=4.3V, IOU=40mA	3.234	3.300	3.366	V
Output Current	IOU	VIN=4.3V, Lower by 0.1V than VOUT	170	300		mA
Load Stability	$\frac{\Delta V_{OUT}}{\Delta I_{OUT}}$	VIN=4.3V 1mA ≤ IOU ≤ 100mA		5	15	mV
Input/Output Voltage Differential	Vdif	IOU=40mA		125	210	mV
Current Consumption	ISS	Vin=4.3V		25	45	μA
Stand-by Current Consumption	Istandby	VIN=4.3V, VCE=VSS		0.1	0.5	μA
Input Stability	$\frac{\Delta V_{OUT}}{\Delta V_{IN}}$	4.3V ≤ VIN ≤ 8.0V IOU=40mA		0.15	0.30	%/V
Input Voltage	VIN				8.0	V
Output Voltage Temp. Characteristics	$\frac{\Delta V_{OUT}}{\Delta T_{top}}$	VIN=4.3V, IOU=40mA -30°C ≤ Top ≤ +80°C		±100		ppm/°C
Short-circuit Current	Ilim	VOUT=0V		70		mA
CE Input Voltage "H"	VCEH	VIN=8.0V	1.80		VIN	V
CE Input Voltage "L"	VCEL	VIN=2.0V	0		0.25	V
CE Input Current "H"	ICEH	VCE=VIN		0.4	1.5	μA
CE Input Current "L"	ICEL	VCE=VSS	-0.2	0		μA

ELM99503A

(Top=25°C)

Parameter	Symbol	Conditions	Min.	Typ.	Max.	Units
Output Voltage	VOUT	VIN=6.0V, IOU=40mA	4.900	5.000	5.100	V
Output Current	IOU	VIN=6.0V, Lower by 0.1V than VOUT	200	330		mA
Load Stability	$\frac{\Delta V_{OUT}}{\Delta I_{OUT}}$	VIN=6.0V 1mA ≤ IOU ≤ 100mA		5	15	mV
Input/Output Voltage Differential	Vdif	IOU=40mA		105	170	mV
Current Consumption	ISS	VIN=6.0V		30	55	μA
Stand-by Current Consumption	Istandby	VIN=6.0V, VCE=VSS		0.1	0.5	μA
Input Stability	$\frac{\Delta V_{OUT}}{\Delta V_{IN}}$	6.0V ≤ VIN ≤ 8.0V IOU=40mA		0.15	0.30	%/V
Input Voltage	VIN				8.0	V
Output Voltage Temp. Characteristics	$\frac{\Delta V_{OUT}}{\Delta T_{top}}$	VIN=6.0V, IOU=40mA -30°C ≤ Top ≤ +80°C		±100		ppm/°C
Short-circuit Current	Ilim	VOUT=0V		70		mA
CE Input Voltage "H"	VCEH	VIN=8.0V	1.80		VIN	V
CE Input Voltage "L"	VCEL	VIN=2.0V	0		0.25	V
CE Input Current "H"	ICEH	VCE=VIN		0.4	1.5	μA
CE Input Current "L"	ICEL	VCE=VSS	-0.2	0		μA

LOW SATURATION VOLTAGE REGULATOR ELM99xxxA

■ TYPICAL PERFORMANCE CHARACTERISTICS

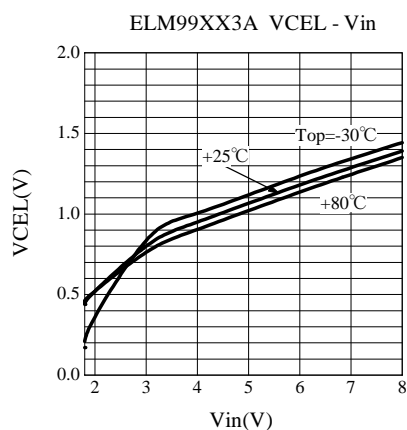
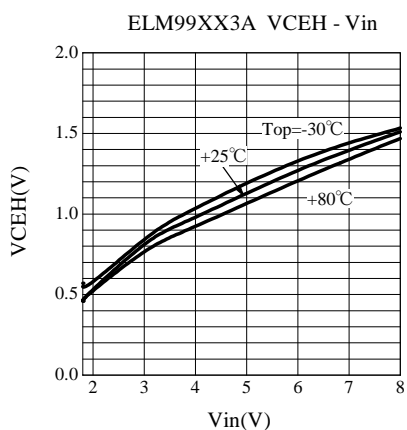
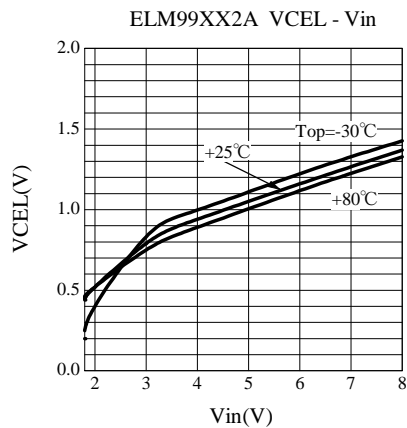
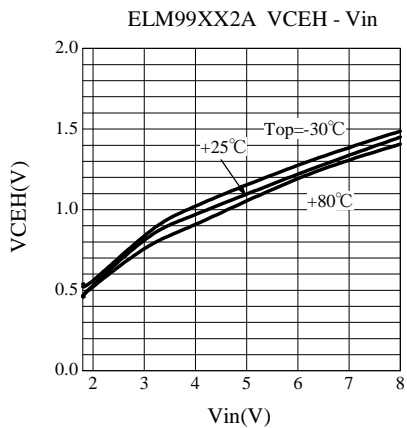

LOW SATURATION VOLTAGE REGULATOR ELM99xxxA

● ELM9927xA

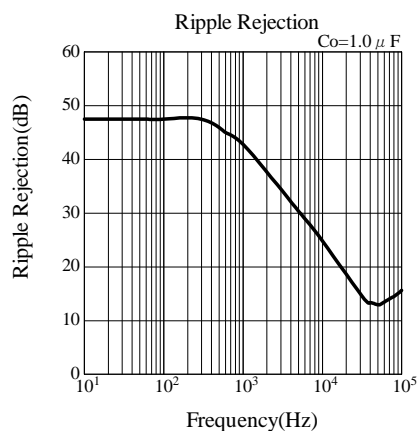
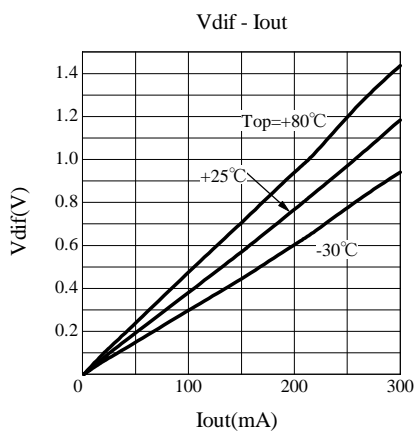
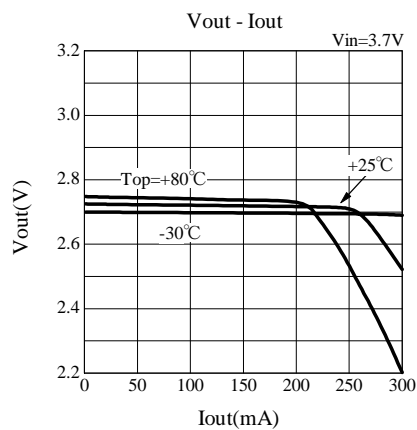
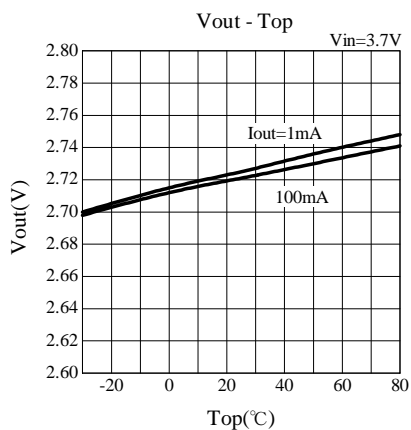
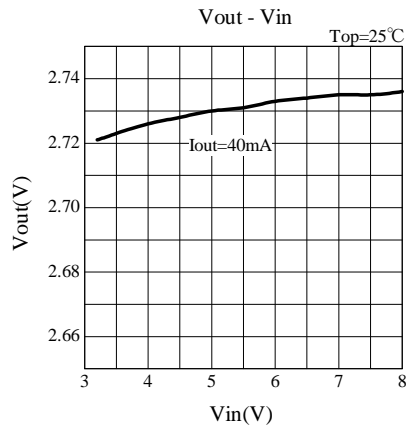
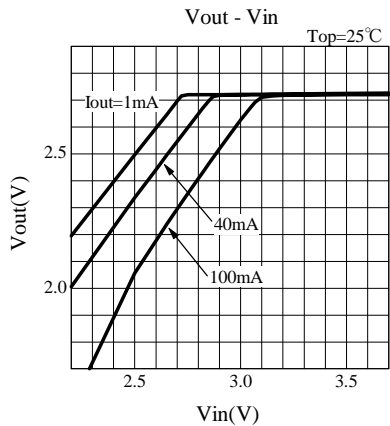

LOW SATURATION VOLTAGE REGULATOR ELM99xxxA

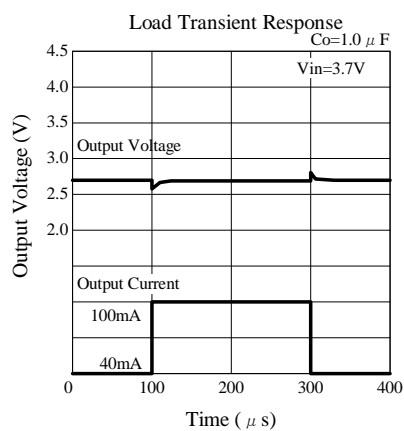
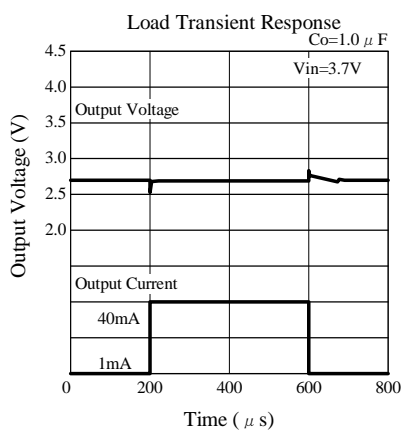
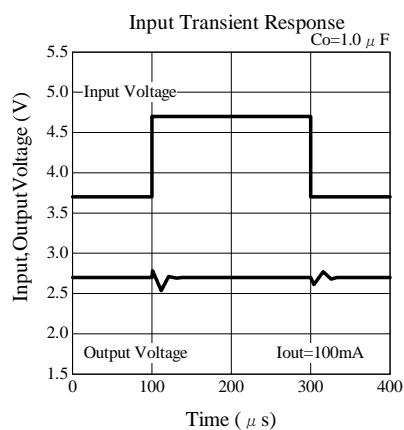
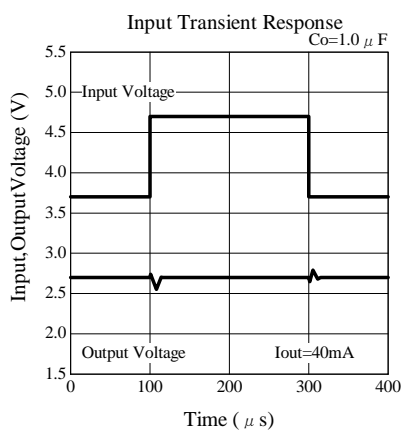
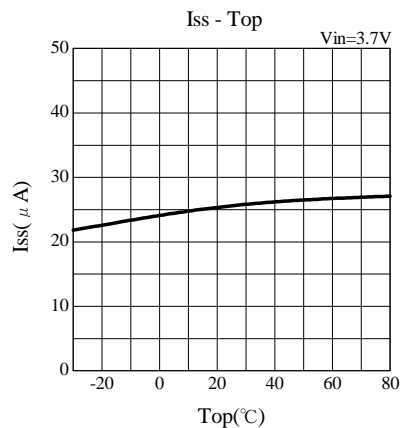
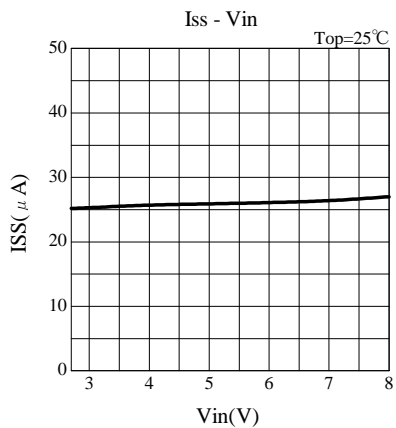

LOW SATURATION VOLTAGE REGULATOR ELM99xxxA

● ELM9930xA

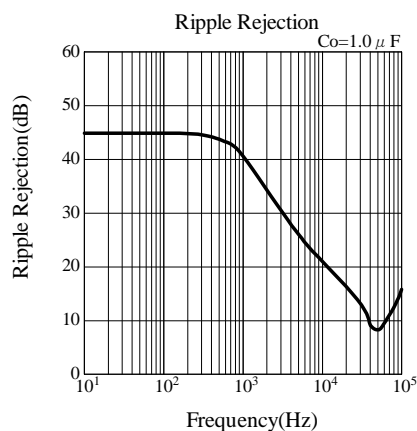
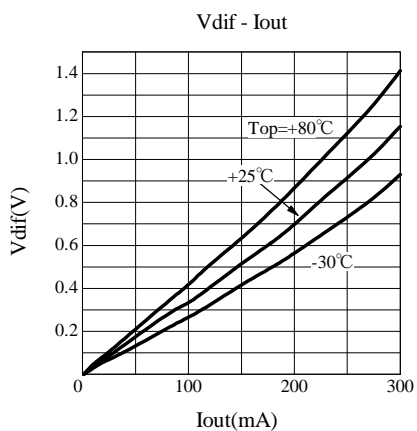
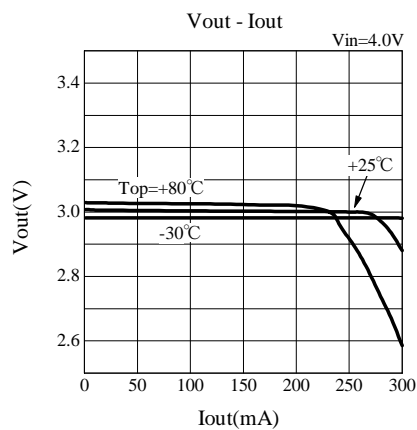
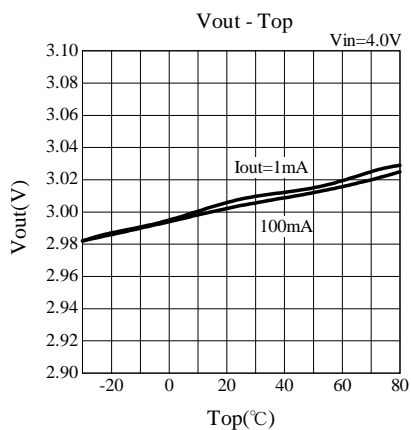
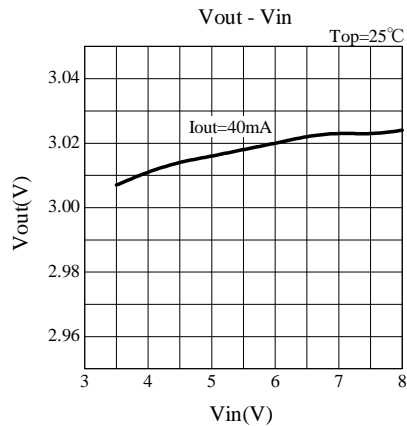
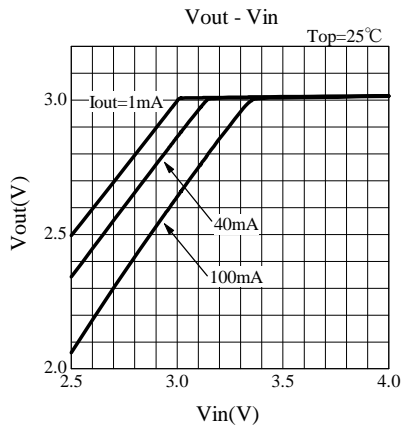

LOW SATURATION VOLTAGE REGULATOR ELM99xxxA

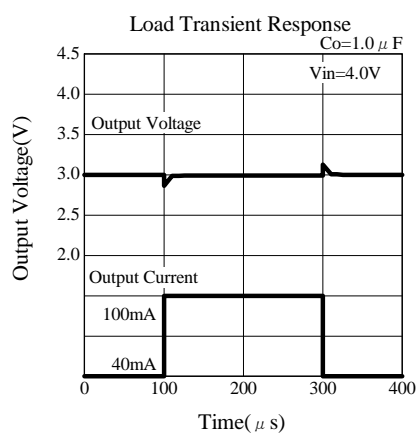
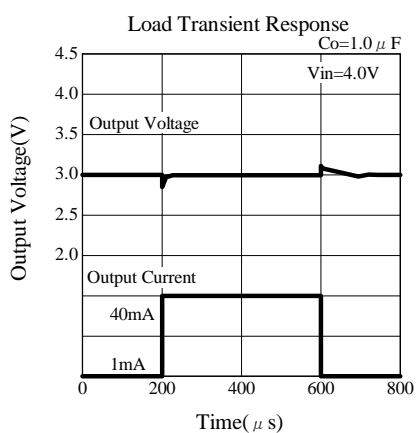
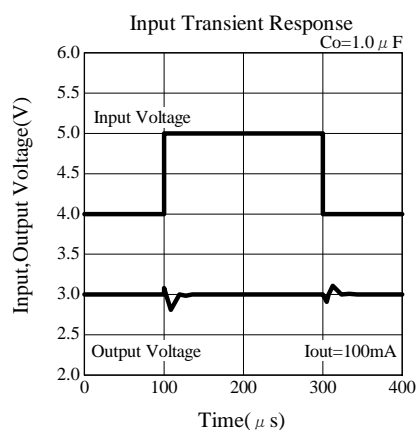
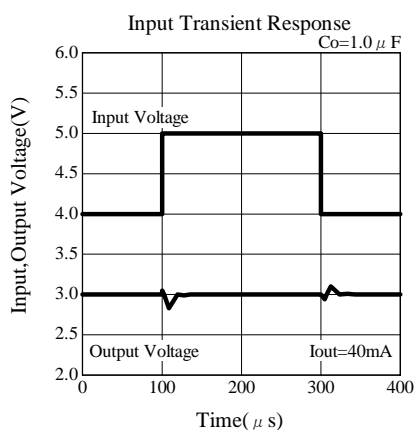
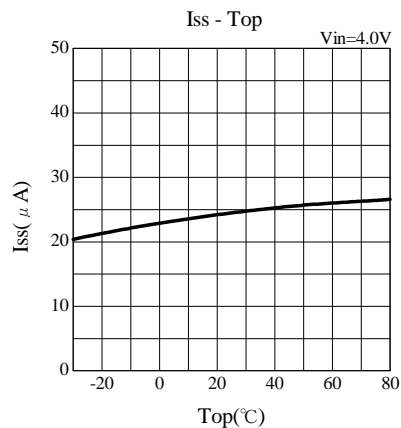
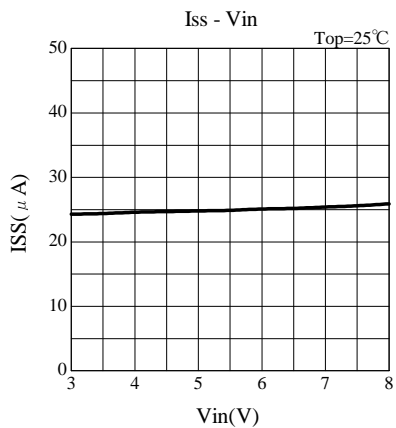

LOW SATURATION VOLTAGE REGULATOR ELM99xxxA

● ELM9933xA

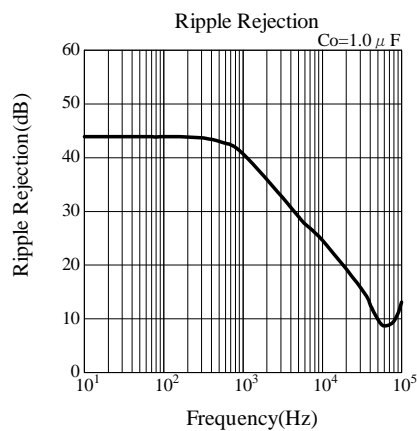
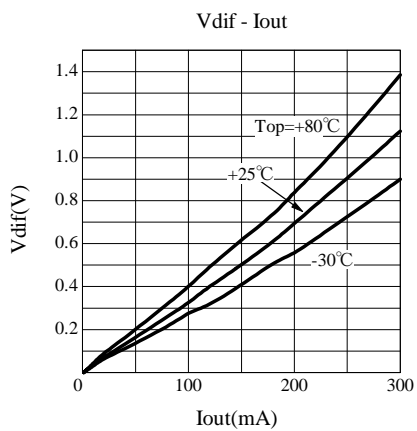
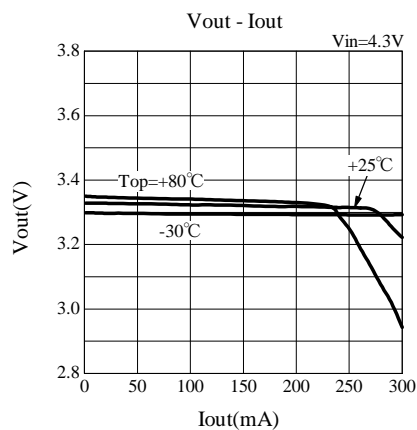
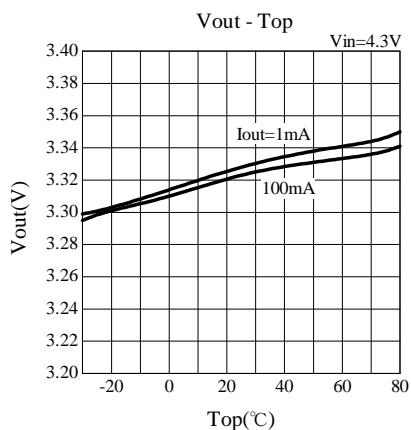
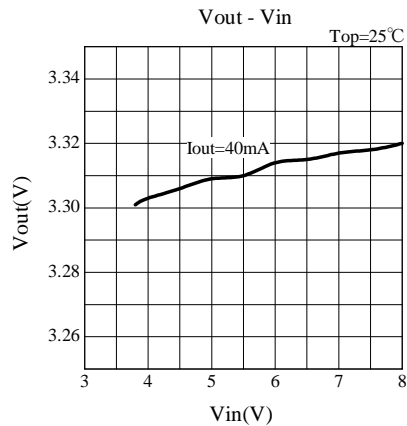
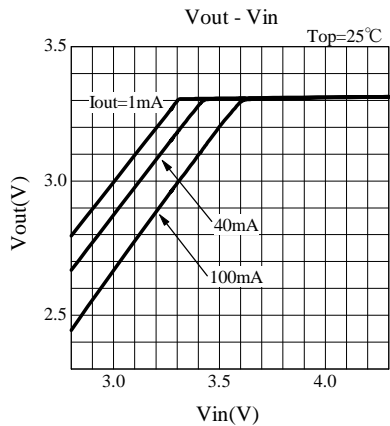

LOW SATURATION VOLTAGE REGULATOR ELM99xxxA

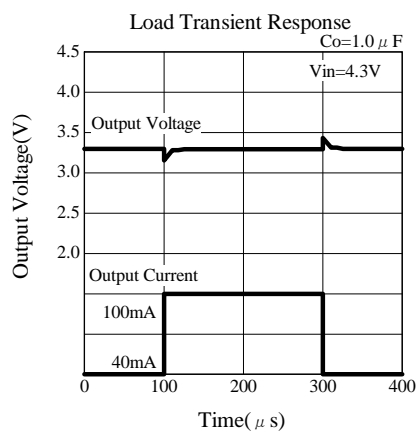
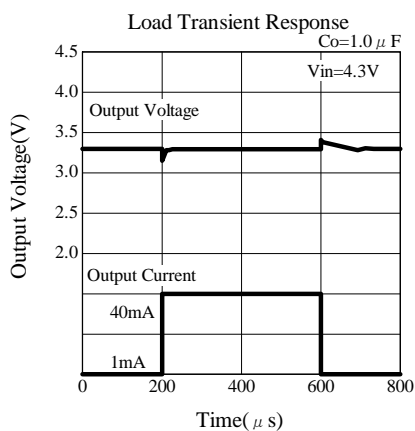
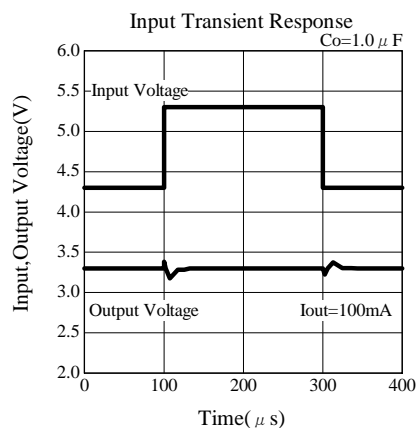
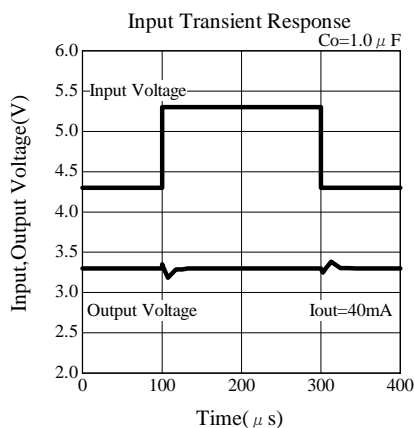
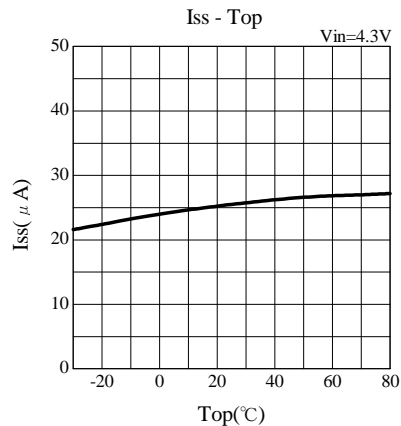
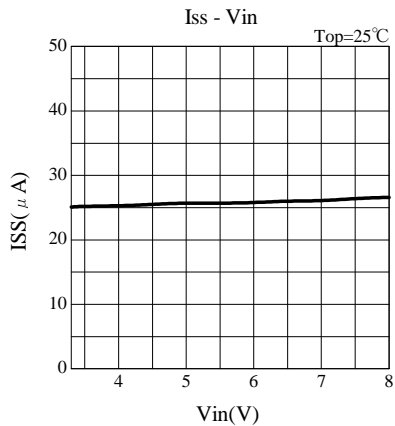

LOW SATURATION VOLTAGE REGULATOR ELM99xxxA

● ELM9950xA

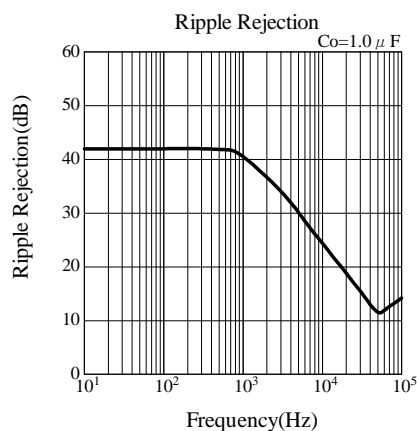
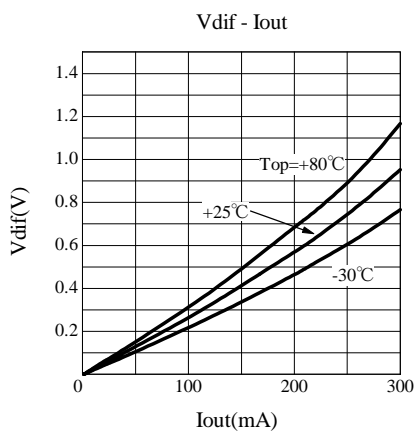
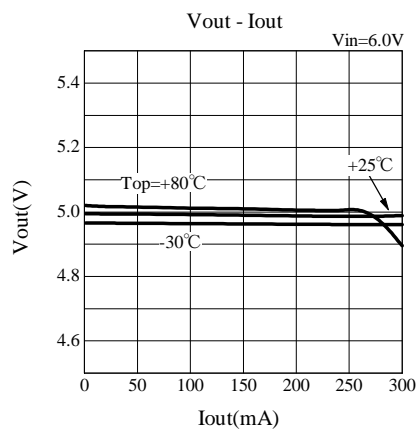
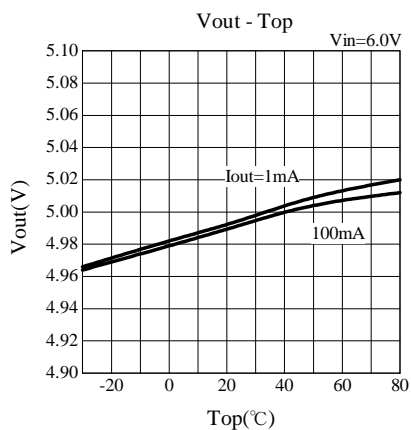
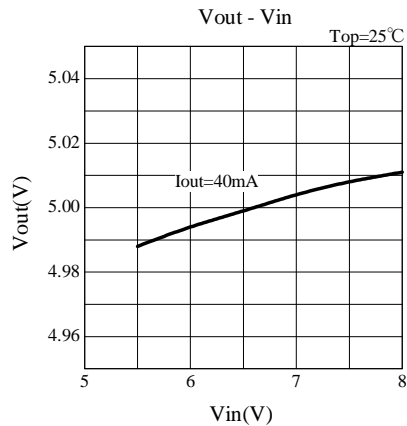
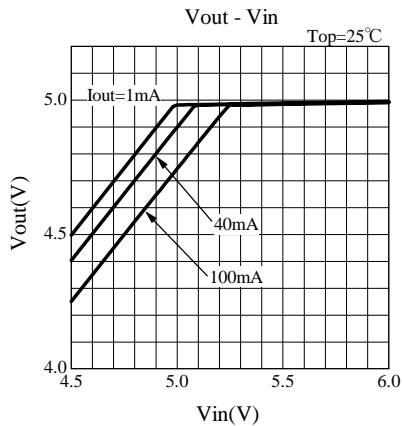

LOW SATURATION VOLTAGE REGULATOR ELM99xxxA

