

DUAL PRE-POWER AMPLIFIER, VOLUME CONTROLLER AND DC MOTOR SPEED CONTROLLER

The KA22136 is a monolithic integrated circuit designed for use in low voltage and low power applications. It has all functions including dual audio pre-power amplifier, electronic volume controller and DC motor speed controller in a single chip. It is suitable for portable tape recorders, headphone cassette tape recorders or radios by batteries.

FEATURES

- Low current consumption in a operating voltage range.
- Operating supply voltage range: $V_{CC} = 2.1V \sim 5V$
- Only a few components in composing headphone cassette tape recorder.
- Dual audio pre-power amplifier, electronic volume controller and DC motor speed controller in a single chip.
- Reduced input and output coupling capacitors because of $\frac{1}{2} V_{CC}$ AMP adaption on chip as AC GND.

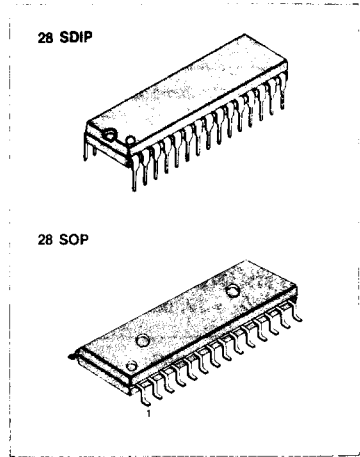

ORDERING INFORMATION

Device	Package	Operating Temperature
KA22136	28SDIP	- 20°C ~ + 65°C
KA22136D	28SOP	

BLOCK DIAGRAM

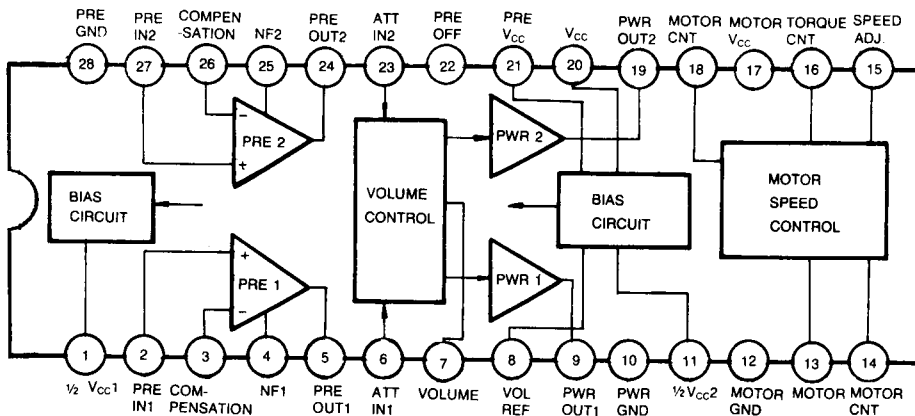

Fig. 1

ABSOLUTE MAXIMUM RATINGS (Ta = 25°C)

Characteristic	Symbol	Value	Unit
Supply Voltage	V _{CC}	7.5	V
Power Dissipation	P _D	450	mW
Operating Temperature	T _{OPR}	-20 ~ +70	°C
Storage Temperature	T _{STG}	-40 ~ +125	°C

ELECTRICAL CHARACTERISTICS(Ta = 25°C, V_{CC} = 3V, unless otherwise specified)

Characteristic	Symbol	Test Condition	Min	Typ	Max	Unit
Quiescent circuit current	I _{CCQ}	V _{CC} = 3V, V _I = 0, I _M = 0		18	25	mA

PRE AMPLIFIER SECTION (V_{CC} = 3V, f = 1KHz, R_{L1} = 10KΩ, unless otherwise specified)

Characteristic	Symbol	Test Condition	Min	Typ	Max	Unit
Open Loop Voltage Gain	G _{VO}	V _O = -10dBm, R _L = ∞		72		dB
Closed Loop Voltage Gain	G _{VC1}	V _O = -10dBm	40	42	44	dB
Output Voltage	V _O	THD = 10%	0.45	0.6		V
Total Harmonic Distortion	THD ₁	V _O = 400mV		0.05	0.5	%
Output Noise Voltage	V _{NO1}	V _I = 0, R _G = 2.2KΩ, BPF (30 ~ 20KHz)		150	300	μV
Input Resistance	R _I	V _O = 10dBm	18	22		KΩ
Cross Talk	CT ₁	R _G = 2.2KΩ, V _O = -10dBm	30			dB
Output Voltage In Pre OFF	V _{O(OFF)}	V _I = 100mV Pre OFF (pin 22) = V _{CC}			-50	dB

POWER AMPLIFIER SECTION (Ta = 25°C, V_{CC} = 3V, f = 1KHz, R_{L2} = 16Ω, unless otherwise specified)

Characteristic	Symbol	Test Condition	Min	Typ	Max	Unit
Closed Loop Voltage Gain	G _{VC2}	P _O = 5mW	26	28	30	dB
Voltage Gain Difference	ΔG _V	V _{CONT} = Max		0	3	dB
Output Power 1	P _{O1}	THD = 10%, R _L = 32Ω	20	28		mW
Output Power 2	P _{O2}	THD = 10%, R _L = 16Ω	30			mW
Total Harmonic Distortion	THD ₂	P _O = 5mW		0.2	2.0	%
Pre + Power Output Noise Voltage	V _{NO2}	V _I = 0, R _G = 2.2KΩ, V _{CONT} = Max		6	10	mV
Output Noise Voltage	V _{NO3}	R _G = 2.2KΩ, V _{CONT} = Min		0.25	1.0	mV
Cross Talk	CT ₂	P _O = 5mW	20	30		dB
Ripple Rejection Ratio	RR	V _{CC} = 3V, 100Hz, 100mVp-p	34	40		dB

ATTENUATOR SECTION ($T_a = 25^\circ\text{C}$, $V_{CC} = 3\text{V}$, $f = 1\text{KHz}$, unless otherwise specified)

Characteristic	Symbol	Test Condition	Min	Typ	Max	Unit
Maximum Input Voltage	$V_{I(\text{MAX})}$		0.2			V
Maximum Attenuation	$V_{\text{ATT}(\text{MAX})}$	$V_{\text{CONT}} = \text{Min}$	66			dB
Attenuation Error	$V_{\text{ATT}(\text{ERR})}$	$V_{\text{CONT}} = \text{Max}$		0		dB
Input Impedance	Z_i		15	20		$\text{K}\Omega$

MOTOR SPEED CONTROLLER ($T_a = 25^\circ\text{C}$, $V_{CC} = 3\text{V}$, $I_M = 100\text{mA}$, unless otherwise specified)

Characteristic	Symbol	Test Condition	Min	Typ	Max	Unit
Circuit Current	I_{CCD}			3.0	5.0	mA
Starting Current	I_{ST}		500			mA
Reference Voltage	V_{REF}	V (pin 15, 16)	0.72	0.80	0.87	V
Reference Voltage Regulation 1	ΔV_{REF1}	* $V_{\text{CC}} = 2.1 \sim 5.0\text{V}$		0.05		%/V
Reference Voltage Regulation 2	ΔV_{REF2}	$I_M = 25 \sim 250\text{mA}$		0.01		%/mA
Reference Voltage Regulation 3	ΔV_{REF3}	$T_a = -10 \sim 50^\circ\text{C}$		0.01		%/°C
Current Coefficient	K		32	38	43	
Current Coefficient Regulation 1	ΔK_1	$V_{\text{CC}} = 2.1 \sim 5.0\text{V}$		0.50		%/V
Current Coefficient Regulation 2	ΔK_2	$I_M = 25 \sim 250\text{mA}$		0.05		%/mA
Current Coefficient Regulation 3	ΔK_3	$T_a = -10 \sim 50^\circ\text{C}$		0.02		%/°C
Saturation Voltage	V_{SAT}	$I_M = 200\text{mA}$, Pin14 = V_{CC}			0.6	V
Leakage Current	I_{LKG}	Pin 18 = V_{CC}		50	200	μA

*Voltage across Pin 13, 17

TEST CIRCUIT

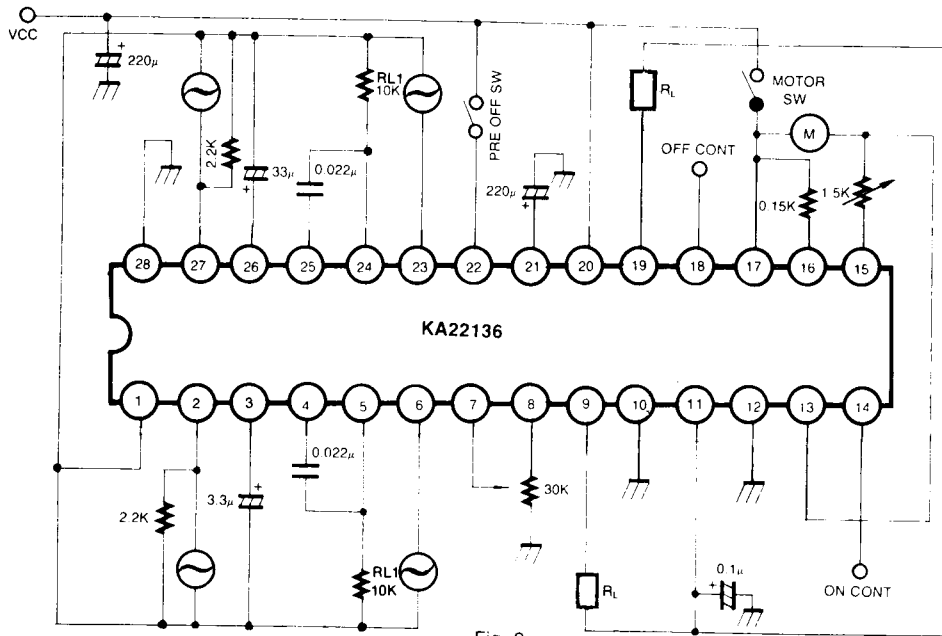

Fig. 2

APPLICATION CIRCUIT

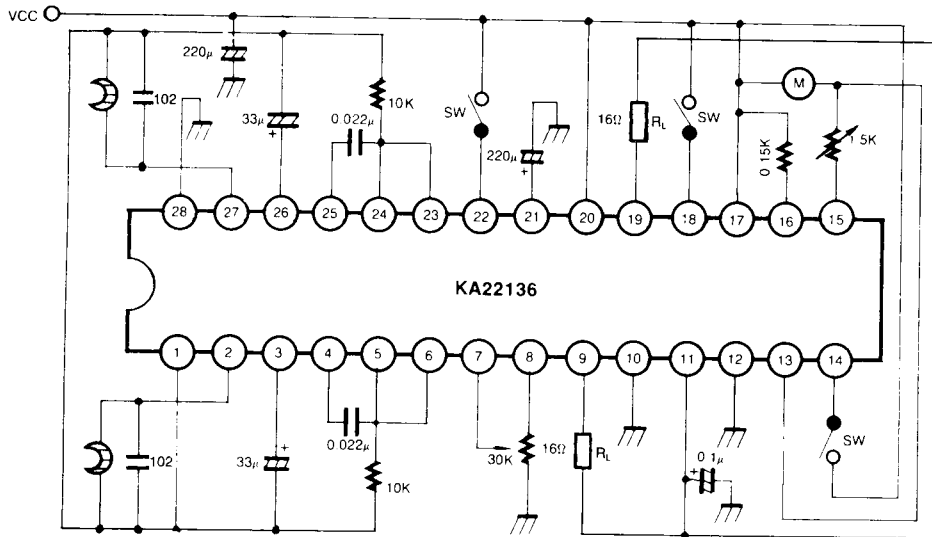

Fig. 3