

Versatile Debounce Circuit

Description

The ELM409 is digital filter circuit that is used to interface mechanical contacts to electronic circuits.

All mechanical contacts, whether from switches, relays, etc. will have inherent 'bounce' when they make or break a connection. When that contact is used for the electrical input to a digital circuit, the bounces can easily be incorrectly interpreted as multiple inputs. The ELM409 contains all of the logic that is typically required to remove the bounce from such signals, and provide a signal that has only one transition.

In addition to providing the standard debounce function, the ELM409 may also be configured for other useful functions such as generating pulses or alternating output levels on signal transitions.

No external components are needed for the operation of the ELM409, as all timing and logic functions are performed internally.

Features

- Standard and extra long debounce times
- Schmitt input provides hysteresis
- Complementary circuit outputs
- Needs no external timing components
- Low power CMOS design - typically 1 mA at 5V
- Wide supply range - 3.0 to 5.5 volt operation
- High current drive outputs

Applications

- Pushbutton interface for logic circuits
- Limit switch monitoring
- Time delay generation
- Power on sequencing

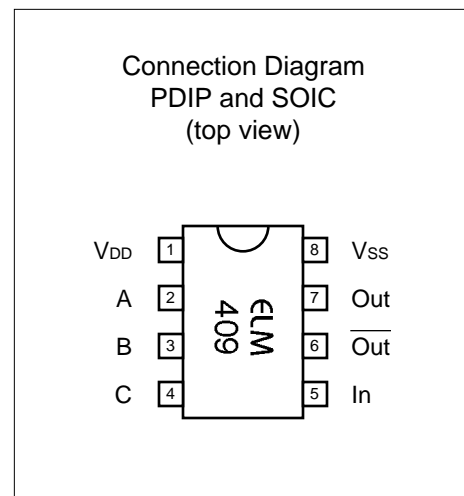

Block Diagram

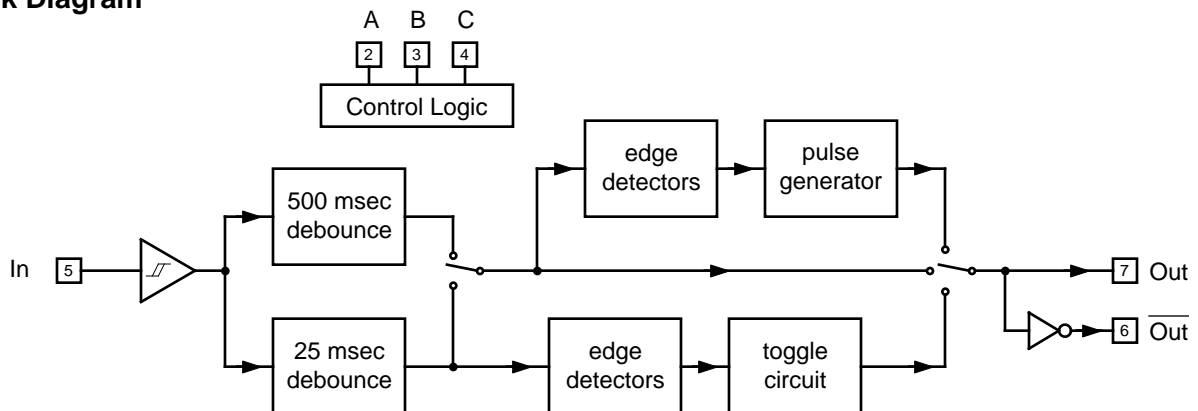



Pin Descriptions

V_{DD} (pin 1)

This pin is the positive supply pin, and should always be the most positive point in the circuit. Internal circuitry connected to this pin is used to provide power-on reset of the microprocessor, so an external reset signal is not required. Refer to the Electrical Characteristics section for further information.

A, B, and C (pins 2, 3, and 4)

These three pins modify the behaviour of the ELM409, providing eight different configurations. They determine whether the output should follow the input, be a momentary pulse, or toggle the output on each input transition. As well, they can select either a standard 25 msec debounce period, or a longer 500 msec one. The longer period may be useful for some very noisy interfaces, or for situations that need a slight delay. See the "ELM409 Operation" section for more details on these options.

In (pin 5)

The signal that is to be processed is applied to this pin. Before the signal is 'debounced', it is passed through a Schmitt trigger - a special buffer circuit that has hysteresis in its gain function. The use of

hysteresis means that very slow moving or noisy signals can be accommodated by the ELM409 without needing the signal to be preconditioned by any external circuitry. (A standard CMOS input should never have a slowly varying signal applied, as it may cause excessive currents to flow internally, but a Schmitt input circuit does not have this limitation.)

Out (pin 7) and $\overline{\text{Out}}$ (pin 6)

The 'debounced' and processed signal is output on pin 7, while the complement of this signal is output on pin 6. These are high current CMOS drivers, so will interface to virtually all of the common digital logic families.

V_{SS} (pin 8)

Circuit common is connected to this pin. This should be the most negative point in the circuit.

Ordering Information

These integrated circuits are available in either the 300 mil plastic DIP format, or in the 208 mil SOIC surface mount type of package. To order, add the appropriate suffix to the part number:

300 mil Plastic DIP..... ELM409P

208 mil SOIC..... ELM409SM

All rights reserved. Copyright 2009 by Elm Electronics Inc.

Every effort is made to verify the accuracy of information provided in this document, but no representation or warranty can be given and no liability assumed by Elm Electronics with respect to the accuracy and/or use of any products or information described in this document. Elm Electronics will not be responsible for any patent infringements arising from the use of these products or information, and does not authorize or warrant the use of any Elm Electronics product in life support devices and/or systems. Elm Electronics reserves the right to make changes to the device(s) described in this document in order to improve reliability, function, or design.



Absolute Maximum Ratings

Storage Temperature..... -65°C to +150°C
 Ambient Temperature with
 Power Applied..... -40°C to +85°C
 Voltage on V_{DD} with respect to V_{SS}..... 0 to +7.5V
 Voltage on any other pin with
 respect to V_{SS}..... -0.6V to (V_{DD} + 0.6V)

Note:
 Stresses beyond those listed here will likely damage the device. These values are given as a design guideline only. The ability to operate to these levels is neither inferred nor recommended.

Electrical Characteristics

All values are for operation at 25°C and a 5V supply, unless otherwise noted. For further information, refer to note 1 below.

Characteristic	Minimum	Typical	Maximum	Units	Conditions	
Supply Voltage, V _{DD}	3.0	5.0	5.5	V		
V _{DD} rate of rise	0.05			V/ms	see note 2	
Average Supply Current, I _{DD}		1.0	2.4	mA	see note 3	
Input (pin 5) Schmitt trigger thresholds	rising		2.9	4.0	V	V _{DD} = 5.0V
	falling	1.0	1.5		V	
Input (pin 5) Schmitt trigger thresholds	rising		1.6	2.4	V	V _{DD} = 3.0V
	falling	0.6	1.0		V	
Output low voltage		0.3		V	Current (sink) = 10 mA	
Output high voltage		4.2		V	Current (source) = 10 mA	
Standard debounce time		25		msec	see note 4	
Long debounce time		500		msec	see note 4	
Output pulse width		50		msec	see note 4	

Notes:

1. This integrated circuit is produced using one of the Microchip Technology Inc.'s PIC12C5XX products as the core embedded microcontroller. For further device specifications, and possibly clarification of those given, please refer to the appropriate Microchip documentation.
2. This spec must be met in order to ensure that a correct power on reset occurs. It is quite easily achieved using most common types of supplies, but may be violated if one uses a slowly varying supply voltage, as may be obtained through direct connection to solar cells, or some charge pump circuits.
3. Device only. Does not include any current supplied to external circuits.
4. The ELM409 uses an internal RC oscillator for the timing. This oscillator typically maintains an accuracy of 2% over the allowed temperature and voltage range.

About Contact Bounce

The circuit of Figure 1 below shows one possible connection that might be made between a mechanical switch and a digital circuit. The pushbutton could be used to summon an elevator, or to turn a circuit on, or it could be a switch that is operated by foot pressure to count the number of people entering a room. It does not matter what the function is actually - in every case we simply need a clean signal to present to the logic.

Normally, the pushbutton will not be pressed, so its contacts will be open, and the digital circuit will 'see'

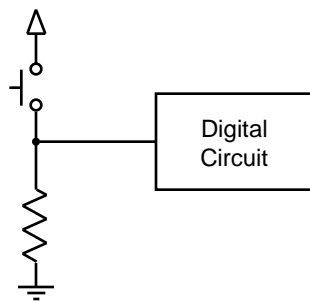

Figure 1. Pushbutton input to digital logic

only a resistor to circuit common (a 'low' input). When the pushbutton is pressed, the contacts close and the digital circuit will be connected to the positive power supply, or a logic 'high'. It should be a simple matter of processing this signal, but it is often not.

The oscilloscope trace of Figure 2 shows the voltage that the digital circuit of Figure 1 might see when the pushbutton is pressed. It is an actual trace

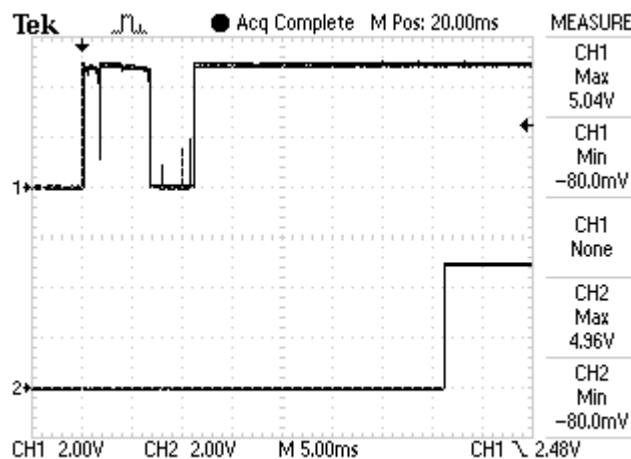

Figure 2. Bounce on switch closing

taken from our pushbutton tests (and shows the output from the ELM409 in the lower trace). Note that the signal alternates between high and low several times, bouncing between the levels. This bounce occurs when the moving contacts of the switch meet the stationary contacts, and is simply due to the physics of the two parts meeting one another. The bounces do not seem to have a defining characteristic that would allow the behaviour to be predicted and filtered - it is basically digital noise.

If this signal were to be input to the digital circuit as it is, it would be seen as at least two switch presses (and maybe more). Note that when the contacts open, there is a similar problem, as shown in Figure 3:

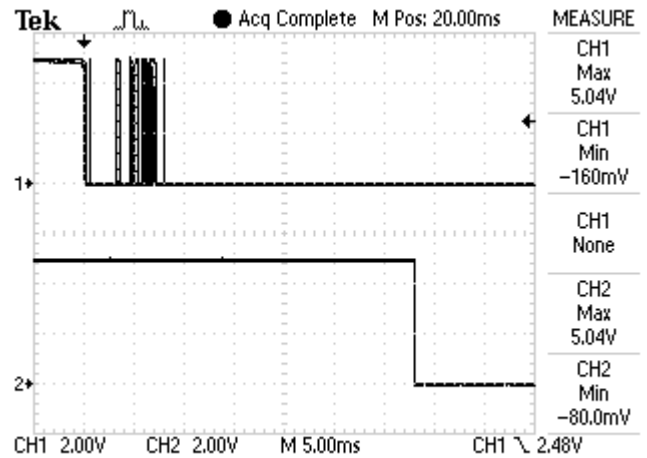

Figure 3. Bounce on switch opening

Seeing multiple inputs for a single switch press is certainly not what is intended by any circuit, and it needs to be addressed. The technique of 'cleaning up' such a signal is commonly known as 'debouncing', and that is what the ELM409 does. It simply waits until the bounces stop, then waits an additional time (the debounce time) to be sure that there are no more bounces likely to occur. Choosing an appropriate debounce time is a design choice, but 25 msec seems to be a good value.

There are several analog methods of performing the 'debouncing' of a signal, many that work extremely well, but we do not think that any work better than the ELM409.

ELM409 Operation

The circuit of Figure 4 shows how the ELM409 would typically be connected to debounce the signal of Figure 1. Other than powering the ELM409, all that is needed is to connect the options pins (A, B and C) to V_{ss} (providing low levels on all three), connect the noisy switch signal to the input pin, and then connect the ELM409 output pin to the digital circuit.

The output of the ELM409 in Figure 4 would appear as shown in the 'scope traces of Figures 2 and 3 (the lower traces). There is a slight delay (25 msec) due to the debounce period, but otherwise, the signal appears as you would expect from an 'ideal' switch.

The ELM409 is capable of performing several other functions on the input signal - it can do more than just debounce the signal. For example, it can provide a change in output on the signal edges (transitions from a low to a high level, or from a high to a low level), and it can alternate (toggle) the output on each occurrence of an edge. Each of these possibilities are selected by changing the logic levels at the A, B and C pins. The eight combinations are described in Table 1 below, and also appear pictorially on the next page.

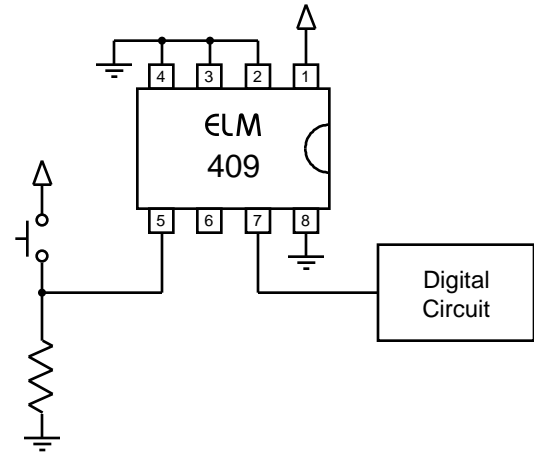

Figure 4. Debouncing the pushbutton

Function	A	B	C	Debounce Period	Notes
Follows Input	0	0	0	25 msec	Standard contact debounce
	0	0	1	500 msec	For very noisy circuits
Pulse on Rising Edge	0	1	0	25 msec	Output pulse is 50 msec wide
	0	1	1	500 msec	Output pulse is 50 msec wide
Pulse on Falling Edge	1	0	0	25 msec	Output pulse is 50 msec wide
	1	0	1	500 msec	Output pulse is 50 msec wide
Toggle on Edge	1	1	0	25 msec	Changes on input H -> L
	1	1	1	25 msec	Changes on input L -> H

Table 1. ELM409 options

ELM409 Operation (continued)

The following diagrams provide a pictorial view of each of the eight ELM409 options:

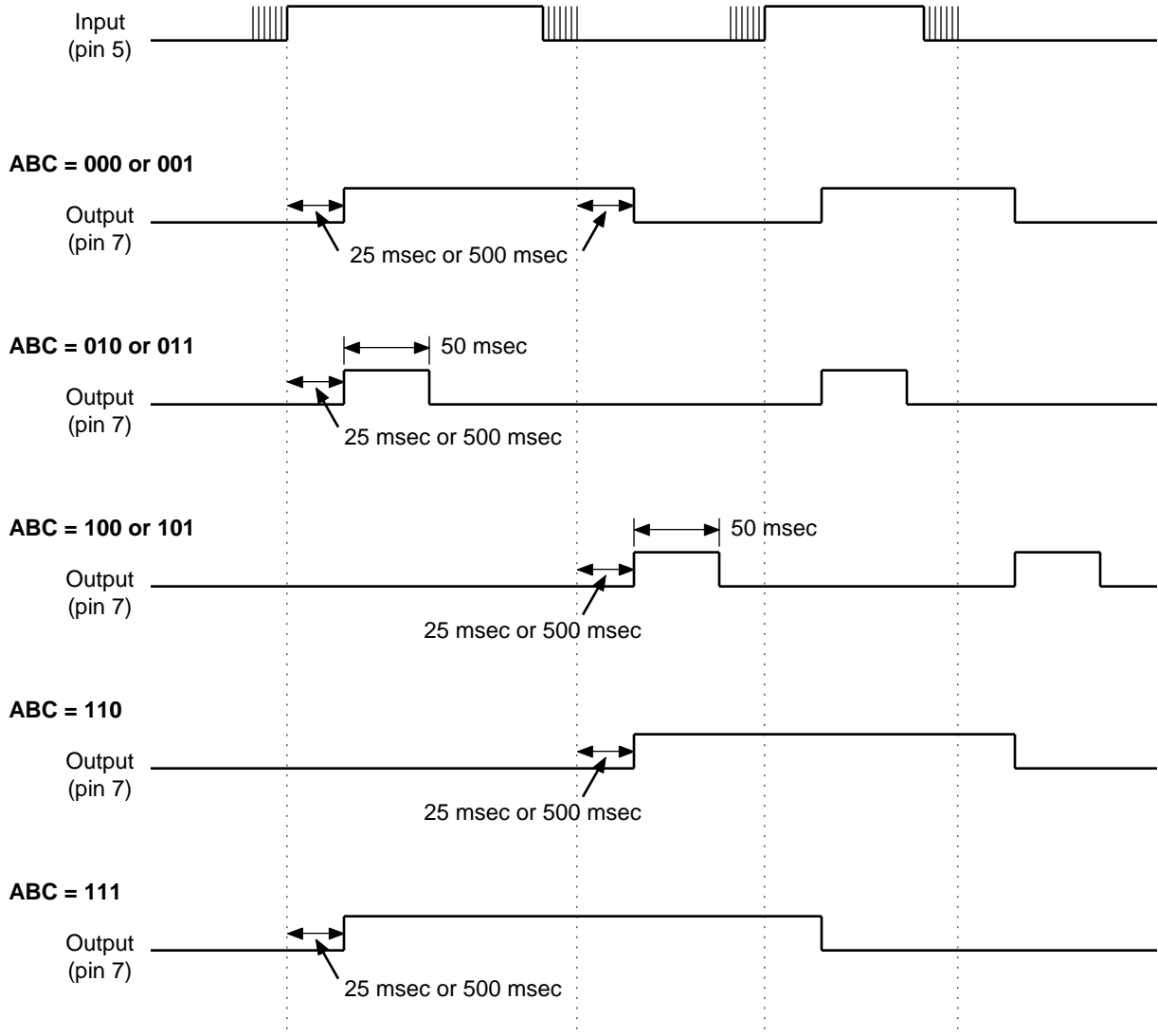

Figure 5. ELM409 Timing Diagrams

Example Applications

This section shows several different ways to use the ELM409. The first example (Figure 6) is actually a variation of the circuit shown in Figure 4.

Figure 6 adds two components that should always be considered in every ELM409 design. The first is a supply bypass capacitor. Digital circuits will often have transients ('spikes') in their current flow due to the internal switching process. By adding a capacitor very close to the IC, much of the current for these spikes can be supplied by the capacitor rather than through the (inductive) leads from the supply. The net result is that there will be less noise generated at the supply by the ELM409. A value of $0.01\mu\text{F}$ works well.

The other component that was added in Figure 6 is a series resistor at the input (pin 5). This resistor is recommended when the electrical contact or switch is any more than a few feet away from the ELM409 IC. Placing the resistor in series with the input serves to limit induced currents that might otherwise damage the ELM409. A minimum value of a few hundred ohms is recommended, and a larger value (such as the 4.7K shown), is preferred.

The next example (shown in Figure 7) has the pushbutton connected between circuit common and the input, rather than from the positive supply. An arrow is shown at the output, symbolizing the output signal, which is then connected as appropriate.

The one difference with this circuit is that the input voltage will go from a high level to a low level when the switch is pressed. To accommodate this, the options pins have been set to 110, providing a toggle function that changes state on each high to low transition. The circuit will provide alternating high and low outputs which change state each time the switch is pressed.

If the options pins had been set to 000 (ie all tied low), the circuit would provide an output that follows the switch presses, but might seem inverted. That is, pin 7 would normally be at a high level, and would go to a low level when the switch is pressed. If an output that is normally low and goes high when the switch is pressed is required, simply use pin 6 for the output rather than pin 7.

This section concludes on page 8, with three more example circuits and a short description of each.

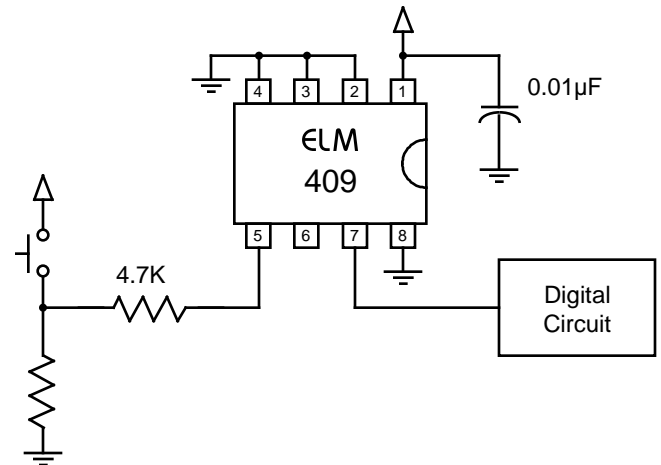

Figure 6. Debouncing the pushbutton revisited

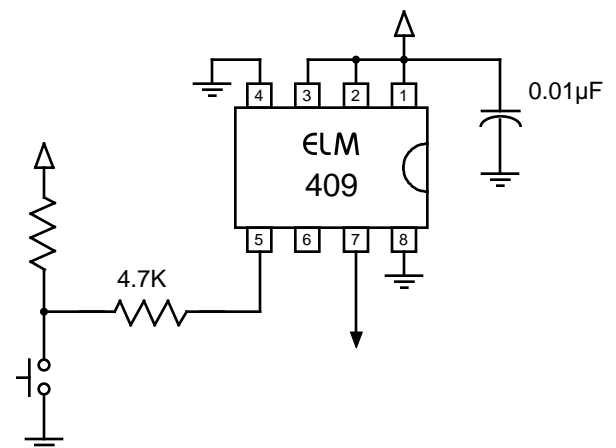

Figure 7. Toggle circuit with the pushbutton to common

Example Applications (continued)

The following are a few circuits that use the ELM409, but may not be what comes to mind when you think of debouncing. They take advantage of the internal timers in the ELM409 as well as the ability to change options while the circuit is operational, to provide some interesting functions.

The first (Figure 8) is a circuit that simply connects the debounce input to the positive supply. With the debounce period set for 500 msec, the output will initially be low, then go high 500 msec after the power is turned on. This delay may be useful if trying to sequence the power to different circuits, or enable the outputs (audio power amplifiers often need this delay to allow the supplies to settle before connecting the amplifier outputs to the speakers).

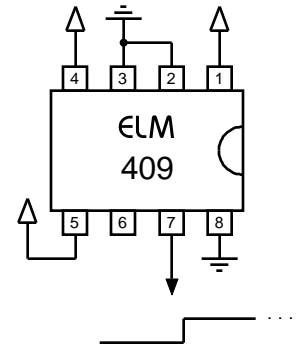

Figure 8. Power on delay

Figure 9 shows a circuit that provides a single 50 msec wide pulse at the output, 25 msec after power has been applied. It relies on the fact that the ELM409's pin 7 output is always at a low level on power up (and pin 6 is always high), so the initial options setting will then be 010, for a 50 msec pulse after a 25 msec debounce period. Once the output pulse begins, however, the connection from pin 7 to pin 4 causes the options to change to 011, giving a debounce period of 500 msec (which can never be met by a 50 msec pulse). The output remains low from that time on.

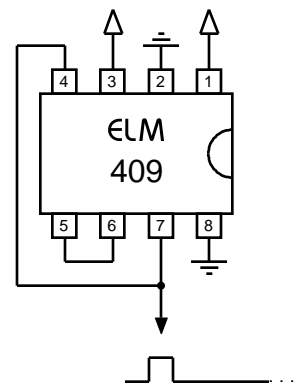

Figure 9. Power on pulse

This circuit works because the option pins are always read just before a 25 msec debounce period is about to expire (allowing for changes 'on the fly'). In this case, the pulse output is at its midpoint when the pins are read, so the new latched setting becomes 011, and the debounce period changes to 500 msec. As the pulse never lasts that long, it is ignored by the 500 msec debounce circuit, and the output never changes again.

The final circuit also uses the output to modify the input, and the debounce period. The result is a series of 25 msec pulses with 500 msec gaps in between, that continually repeat. Low frequency oscillators such as this may be useful on the test bench, or it may simply be used to drive an LED in order to attract attention.

These are just a few of the many applications possible with the ELM409... Enjoy!

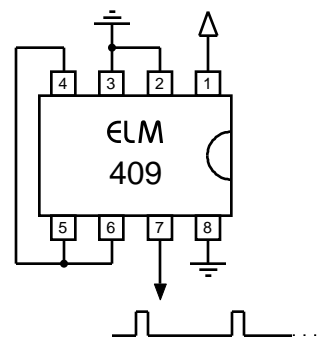

Figure 10. Low frequency oscillator