

## 3 Phase bridge NPT IGBT Power Module

**$V_{CES} = 1200V$**   
 **$I_C = 50A @ T_c = 80^\circ C$**

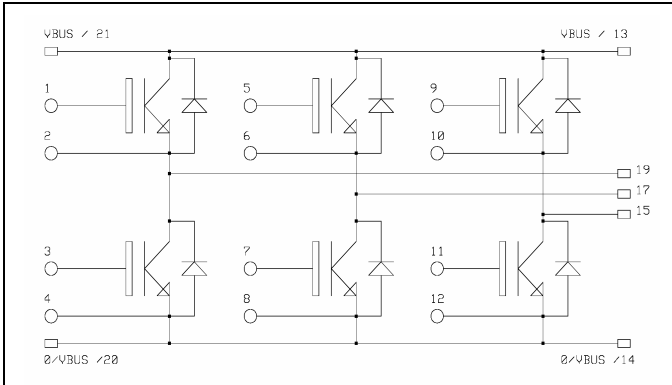

### Application

- AC Motor control

### Features

- Non Punch Through (NPT) IGBT®
  - Low voltage drop
  - Low tail current
  - Switching frequency up to 20 kHz
  - Soft recovery parallel diodes
  - Low diode VF
  - Low leakage current
  - Avalanche energy rated
  - RBSOA and SCSOA rated
- Kelvin emitter for easy drive
- Very low stray inductance
- High level of integration

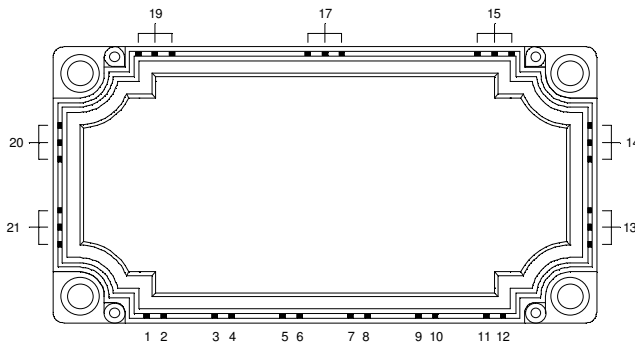

### Benefits

- Stable temperature behavior
- Very rugged
- Solderable terminals for easy PCB mounting
- Direct mounting to heatsink (isolated package)
- Low junction to case thermal resistance
- Easy paralleling due to positive TC of VCEsat
- Low profile

### Absolute maximum ratings

Symbol	Parameter	Max ratings	Unit
$V_{CES}$	Collector - Emitter Breakdown Voltage	1200	V
$I_C$	Continuous Collector Current	$T_C = 25^\circ C$	78
		$T_C = 80^\circ C$	50
$I_{CM}$	Pulsed Collector Current	$T_C = 25^\circ C$	150
$V_{GE}$	Gate - Emitter Voltage	$\pm 20$	V
$P_D$	Maximum Power Dissipation	$T_C = 25^\circ C$	400
SCSOA	Short Circuit Safe Operating Area	$T_j = 125^\circ C$	500A@1200V

 **CAUTION:** These Devices are sensitive to Electrostatic Discharge. Proper Handling Procedures Should Be Followed.

## Electrical Characteristics

All ratings @  $T_j = 25^\circ\text{C}$  unless otherwise specified

Symbol	Characteristic	Test Conditions	Min	Typ	Max	Unit
$BV_{CES}$	Collector - Emitter Breakdown Voltage	$V_{GE} = 0V, I_C = 3mA$	1200			V
$I_{CES}$	Zero Gate Voltage Collector Current	$V_{GE} = 0V$ $V_{CE} = 1200V$		0.8	1	mA
		$T_j = 25^\circ\text{C}$ $T_j = 125^\circ\text{C}$				
$V_{CE(on)}$	Collector Emitter on Voltage	$V_{GE} = 15V$ $I_C = 50A$	2.0	2.5	3.0	V
		$T_j = 25^\circ\text{C}$ $T_j = 125^\circ\text{C}$		3.1	3.7	
$V_{GE(th)}$	Gate Threshold Voltage	$V_{GE} = V_{CE}, I_C = 2 mA$	4.5		6.5	V
$I_{GES}$	Gate - Emitter Leakage Current	$V_{GE} = 20V, V_{CE} = 0V$			200	nA

## Dynamic Characteristics

Symbol	Characteristic	Test Conditions	Min	Typ	Max	Unit
$C_{ies}$	Input Capacitance	$V_{GE} = 0V$		3300		pF
$C_{oes}$	Output Capacitance	$V_{CE} = 25V$		500		
$C_{res}$	Reverse Transfer Capacitance	$f = 1MHz$		220		
$T_{d(on)}$	Turn-on Delay Time	Inductive Switching ( $125^\circ\text{C}$ ) $V_{GE} = \pm 15V$ $V_{Bus} = 600V$ $I_C = 50A$ $R_G = 22\Omega$		44		ns
$T_r$	Rise Time			56		
$T_{d(off)}$	Turn-off Delay Time			380		
$T_f$	Fall Time			70		

## Reverse diode ratings and characteristics

Symbol	Characteristic	Test Conditions	Min	Typ	Max	Unit
$V_F$	Diode Forward Voltage	$I_F = 50A$ $V_{GE} = 0V$		2.3	2.8	V
		$T_j = 25^\circ\text{C}$ $T_j = 125^\circ\text{C}$		1.8		
$t_{rr}$	Reverse Recovery Time	$I_F = 50A$ $V_R = 600V$ $di/dt = 800A/\mu s$		200		ns
$Q_{rr}$	Reverse Recovery Charge	$I_F = 50A$ $V_R = 600V$ $di/dt = 800A/\mu s$		2.8		$\mu C$
		$T_j = 25^\circ\text{C}$ $T_j = 125^\circ\text{C}$		8		

## Thermal and package characteristics

Symbol	Characteristic	Min	Typ	Max	Unit	
$R_{thJC}$	Junction to Case	IGBT		0.35	$^\circ\text{C/W}$	
		Diode		0.7		
$V_{ISOL}$	RMS Isolation Voltage, any terminal to case $t = 1 \text{ min}$ , $I_{isol} < 1mA, 50/60Hz$	2500			V	
$T_j$	Operating junction temperature range	-40		150	$^\circ\text{C}$	
$T_{STG}$	Storage Temperature Range	-40		125		
$T_C$	Operating Case Temperature	-40		125		
Torque	Mounting torque	To Heatsink	M5	3	4.5	N.m
Wt	Package Weight				300	g

