



# TSV912H, TSV912AH

High temperature  
rail-to-rail input/output 8 MHz operational amplifiers

## Features

- Rail-to-rail input and output
- Wide bandwidth
- Low power consumption: 820  $\mu$ A typ
- Unity gain stability
- High output current: 35 mA
- Operating range from 2.5 to 5.5 V
- Low input bias current, 1 pA typ
- ESD internal protection  $\geq$  5 kV
- Latch-up immunity

## Applications

- Automotive products

## Description

The TSV912H and TSV912AH operational amplifiers offer low voltage operation and rail-to-rail input and output.

The devices feature an excellent speed/power consumption ratio, offering an 8 MHz gain-bandwidth product while consuming only 1.1 mA maximum at 5 V. They are unity gain stable and feature an ultra-low input bias current.

The TSV912H is a high temperature version of the TSV912, and can operate from  $-40^{\circ}\text{C}$  to  $+150^{\circ}\text{C}$  with unique characteristics. Its main target applications are automotive, but the device is also ideal for sensor interfaces, battery-supplied and portable applications, as well as active filtering.

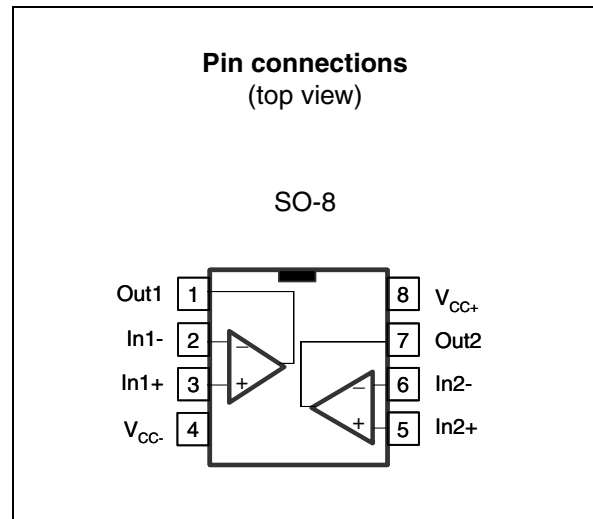

# 1 Absolute maximum ratings and operating conditions

**Table 1. Absolute maximum ratings**

Symbol	Parameter	Value	Unit
$V_{CC}$	Supply voltage <sup>(1)</sup> ( $V_{CC+} - V_{CC-}$ )	6	V
$V_{id}$	Differential input voltage <sup>(2)</sup>	$\pm V_{CC}$	V
$V_{in}$	Input voltage <sup>(3)</sup>	$V_{CC-} - 0.2$ to $V_{CC+} + 0.2$	V
$I_{in}$	Input current <sup>(4)</sup>	10	mA
$T_{stg}$	Storage temperature	-65 to +150	°C
$R_{thja}$	Thermal resistance junction to ambient <sup>(5)</sup> (6) SO-8	125	°C/W
$R_{thjc}$	Thermal resistance junction to case <sup>(5)</sup> (6) SO-8	40	°C/W
$T_j$	Maximum junction temperature	160	°C
ESD	HBM: human body model <sup>(7)</sup>	5	kV
	MM: machine model <sup>(8)</sup>	400	V
	CDM: charged device model <sup>(9)</sup>	1500	V
	Latch-up immunity	200	mA

- All voltage values, except differential voltage, are with respect to network ground terminal.
- Differential voltages are the non-inverting input terminal with respect to the inverting input terminal.
- $V_{CC-} - V_{in}$  must not exceed 6 V.
- Input current must be limited by a resistor in series with the inputs.
- Short-circuits can cause excessive heating and destructive dissipation.
- $R_{th}$  are typical values.
- Human body model: a 100 pF capacitor is charged to the specified voltage, then discharged through a 1.5k $\Omega$  resistor between two pins of the device. This is done for all couples of connected pin combinations while the other pins are floating.
- Machine model: a 200 pF capacitor is charged to the specified voltage, then discharged directly between two pins of the device with no external series resistor (internal resistor < 5  $\Omega$ ). This is done for all couples of connected pin combinations while the other pins are floating.
- Charged device model: all pins and the package are charged together to the specified voltage and then discharged directly to the ground through only one pin. This is done for all pins.

**Table 2. Operating conditions**

Symbol	Parameter	Value	Unit
$V_{CC}$	Supply voltage ( $V_{CC+} - V_{CC-}$ )	2.5 to 5.5	V
$V_{icm}$	Common mode input voltage range	$V_{CC-} - 0.1$ to $V_{CC+} + 0.1$	V
$T_{oper}$	Operating free-air temperature range	-40 to +150	°C

## 2 Electrical characteristics

**Table 3. Electrical characteristics at  $V_{CC+} = +2.5\text{ V}$  with  $V_{CC-} = 0\text{ V}$ ,  $V_{icm} = V_{CC}/2$ ,  $R_L$  connected to  $V_{CC}/2$ ,  $T = 25^\circ\text{C}$  (unless otherwise specified)**

Symbol	Parameter	Conditions	Min.	Typ.	Max.	Unit
<b>DC performance</b>						
$V_{io}$	Input offset voltage	TSV912H, $T=25^\circ\text{C}$ TSV912H, $T_{min} < T < T_{max}$		0.1	4.5 7.5	mV
		TSV912AH, $T=25^\circ\text{C}$ TSV912AH, $T_{min} < T < T_{max}$			1.5 3	
$DV_{io}/DT$	Input offset voltage drift	$-40^\circ\text{C} < T < +125^\circ\text{C}$ $+125^\circ\text{C} < T < +150^\circ\text{C}$		2 20		$\mu\text{V}/^\circ\text{C}$
$I_{io}$	Input offset current	$V_{out} = V_{CC}/2$ $T=25^\circ\text{C}$ $T_{min} < T < T_{max}$		1	$10^{(1)}$ 5	pA nA
$I_{ib}$	Input bias current	$V_{out} = V_{CC}/2$ $T=25^\circ\text{C}$ $T_{min} < T < T_{max}$		1	$10^{(1)}$ 5	pA nA
CMR	Common mode rejection ratio $20 \log (\Delta V_{ic}/\Delta V_{io})$	$0\text{V}$ to $2.5\text{V}$ , $V_{out} = 1.25\text{V}$ $T=25^\circ\text{C}$ $T_{min} < T < T_{max}$	58 53	75		dB
$A_{vd}$	Large signal voltage gain	$R_L = 10\text{k}\Omega$ , $V_{out} = 0.5\text{V}$ to $2\text{V}$ $T=25^\circ\text{C}$ $T_{min} < T < T_{max}$	80 70	89		dB
$V_{CC}-V_{OH}$	High level output voltage	$R_L = 10\text{k}\Omega$ , $T=25^\circ\text{C}$ $R_L = 10\text{k}\Omega$ , $T_{min} < T < T_{max}$		15	40 60	mV
		$R_L = 600\Omega$ , $T=25^\circ\text{C}$ $R_L = 600\Omega$ , $T_{min} < T < T_{max}$		45	150 250	
$V_{OL}$	Low level output voltage	$R_L = 10\text{k}\Omega$ , $T=25^\circ\text{C}$ $R_L = 10\text{k}\Omega$ , $T_{min} < T < T_{max}$		15	40 60	mV
		$R_L = 600\Omega$ , $T=25^\circ\text{C}$ $R_L = 600\Omega$ , $T_{min} < T < T_{max}$		45	150 250	
$I_{out}$	$I_{sink}$	$V_{out} = 2.5\text{V}$ $T=25^\circ\text{C}$ $T_{min} < T < T_{max}$	18 14	32		mA
	$I_{source}$	$V_{out} = 0\text{V}$ $T=25^\circ\text{C}$ $T_{min} < T < T_{max}$	18 14	35		
$I_{CC}$	Supply current (per operator)	No load, $V_{out} = V_{CC}/2$ $T=25^\circ\text{C}$ $T_{min} < T < T_{max}$		0.78	1.1 1.1	mA
<b>AC performance</b>						
GBP	Gain bandwidth product	$R_L = 2\text{k}\Omega$ , $C_L = 100\text{pF}$ , $f = 100\text{kHz}$ $T=25^\circ\text{C}$ $T_{min} < T < T_{max}$		8 4		MHz

## Electrical characteristics

## TSV912H, TSV912AH

**Table 3. Electrical characteristics at  $V_{CC+} = +2.5\text{ V}$  with  $V_{CC-} = 0\text{ V}$ ,  $V_{icm} = V_{CC}/2$ ,  $R_L$  connected to  $V_{CC}/2$ ,  $T = 25^\circ\text{C}$  (unless otherwise specified) (continued)**

Symbol	Parameter	Conditions	Min.	Typ.	Max.	Unit
$F_u$	Unity gain frequency	$R_L = 2\text{k}\Omega$ , $C_L = 100\text{pF}$		7.2		MHz
$\phi_m$	Phase margin	$R_L = 2\text{k}\Omega$ , $C_L = 100\text{pF}$		45		Degrees
$G_m$	Gain margin	$R_L = 2\text{k}\Omega$ , $C_L = 100\text{pF}$		8		dB
SR	Slew rate	$R_L = 2\text{k}\Omega$ , $C_L = 100\text{pF}$ , $A_v = 1$ $T = 25^\circ\text{C}$ $T_{\min} < T < T_{\max}$		4.5 3.5		$\text{V}/\mu\text{s}$
$e_n$	Equivalent input noise voltage	$f = 10\text{kHz}$		21		$\frac{\text{nV}}{\sqrt{\text{Hz}}}$
THD+ $e_n$	Total harmonic distortion	$G = 1$ , $f = 1\text{kHz}$ , $R_L = 2\text{k}\Omega$ , $Bw = 22\text{kHz}$ , $V_{icm} = (V_{CC+} + 1)/2$ , $V_{out} = 1.1V_{pp}$		0.001		%

1. Guaranteed by design.

**Table 4. Electrical characteristics at  $V_{CC+} = +3.3\text{ V}$  with  $V_{CC-} = 0\text{ V}$ ,  $V_{icm} = V_{CC}/2$ ,  $R_L$  connected to  $V_{CC}/2$ ,  $T = 25^\circ\text{C}$  (unless otherwise specified)**

Symbol	Parameter	Conditions	Min.	Typ.	Max.	Unit
<b>DC performance</b>						
$V_{io}$	Input offset voltage	TSV912H, $T = 25^\circ\text{C}$		0.1	4.5	mV
		TSV912H, $T_{\min} < T < T_{\max}$			7.5	
		TSV912AH, $T = 25^\circ\text{C}$			1.5	
		TSV912AH, $T_{\min} < T < T_{\max}$			3	
$DV_{io}$	Input offset voltage drift	$-40^\circ\text{C} < T < +125^\circ\text{C}$ $+125^\circ\text{C} < T < +150^\circ\text{C}$		2 20		$\mu\text{V}/^\circ\text{C}$
$I_{io}$	Input offset current	$V_{out} = V_{CC}/2$ $T = 25^\circ\text{C}$ $T_{\min} < T < T_{\max}$		1	$10^{(1)}$ 5	pA nA
$I_{ib}$	Input bias current	$V_{out} = V_{CC}/2$ $T = 25^\circ\text{C}$ $T_{\min} < T < T_{\max}$		1	$10^{(1)}$ 5	pA nA
CMR	Common mode rejection ratio $20 \log(\Delta V_{ic}/\Delta V_{io})$	$0\text{V}$ to $3.3\text{V}$ , $V_{out} = 1.65\text{V}$ $T = 25^\circ\text{C}$ $T_{\min} < T < T_{\max}$	60 55	78		dB
$A_{vd}$	Large signal voltage gain	$R_L = 10\text{k}\Omega$ , $V_{out} = 0.5\text{V}$ to $2.8\text{V}$ $T = 25^\circ\text{C}$ $T_{\min} < T < T_{\max}$	80 70	90		dB
$V_{CC} - V_{OH}$	High level output voltage	$R_L = 10\text{k}\Omega$ , $T = 25^\circ\text{C}$		15	40	mV
		$R_L = 10\text{k}\Omega$ , $T_{\min} < T < T_{\max}$			60	
		$R_L = 600\Omega$ , $T = 25^\circ\text{C}$		45	150	
		$R_L = 600\Omega$ , $T_{\min} < T < T_{\max}$			250	

**Table 4. Electrical characteristics at  $V_{CC+} = +3.3\text{ V}$  with  $V_{CC-} = 0\text{ V}$ ,  $V_{icm} = V_{CC}/2$ ,  $R_L$  connected to  $V_{CC}/2$ ,  $T = 25^\circ\text{C}$  (unless otherwise specified) (continued)**

Symbol	Parameter	Conditions	Min.	Typ.	Max.	Unit
$V_{OL}$	Low level output voltage	$R_L = 10\text{k}\Omega$ , $T = 25^\circ\text{C}$ $R_L = 10\text{k}\Omega$ , $T_{\min} < T < T_{\max}$		15	40 60	mV
		$R_L = 600\Omega$ , $T = 25^\circ\text{C}$ $R_L = 600\Omega$ , $T_{\min} < T < T_{\max}$		45	150 250	
$I_{out}$	$I_{sink}$	$V_{out} = 3.3\text{V}$ $T = 25^\circ\text{C}$ $T_{\min} < T < T_{\max}$	18 14	32		mA
	$I_{source}$	$V_{out} = 0\text{V}$ $T = 25^\circ\text{C}$ $T_{\min} < T < T_{\max}$	18 14	35		
$I_{CC}$	Supply current (per operator)	No load, $V_{out} = V_{CC}/2$ $T = 25^\circ\text{C}$ $T_{\min} < T < T_{\max}$		0.8	1.1 1.1	mA
<b>AC performance</b>						
GBP	Gain bandwidth product	$R_L = 2\text{k}\Omega$ , $C_L = 100\text{pF}$ , $f = 100\text{kHz}$ , $T = 25^\circ\text{C}$ $T_{\min} < T < T_{\max}$		8 4.2		MHz
$F_u$	Unity gain frequency	$R_L = 2\text{k}\Omega$ , $C_L = 100\text{pF}$		7.2		MHz
$\phi_m$	Phase margin	$R_L = 2\text{k}\Omega$ , $C_L = 100\text{pF}$		45		Degrees
$G_m$	Gain margin	$R_L = 2\text{k}\Omega$ , $C_L = 100\text{pF}$		8		dB
SR	Slew rate	$R_L = 2\text{k}\Omega$ , $C_L = 100\text{pF}$ , $A_v = 1$ , $T = 25^\circ\text{C}$ $T_{\min} < T < T_{\max}$		4.5 3.5		$\text{V}/\mu\text{s}$
$e_n$	Equivalent input noise voltage	$f = 10\text{kHz}$		21		$\frac{\text{nV}}{\sqrt{\text{Hz}}}$
THD+ $e_n$	Total harmonic distortion	$G = 1$ , $f = 1\text{kHz}$ , $R_L = 2\text{k}\Omega$ , $\text{BW} = 22\text{kHz}$ , $V_{icm} = (V_{CC+} + 1)/2$ , $V_{out} = 1.9\text{V}_{pp}$		0.0007		%

1. Guaranteed by design.

## Electrical characteristics

## TSV912H, TSV912AH

**Table 5. Electrical characteristics at  $V_{CC+} = +5\text{ V}$  with  $V_{CC-} = 0\text{ V}$ ,  $V_{icm} = V_{CC}/2$ ,  $R_L$  connected to  $V_{CC}/2$ , full temperature range (unless otherwise specified)**

Symbol	Parameter	Conditions	Min.	Typ.	Max.	Unit
<b>DC performance</b>						
$V_{io}$	Input offset voltage	TSV912H, $T=25^\circ\text{C}$ TSV912H, $T_{min} < T < T_{max}$		0.1	4.5 7.5	mV
		TSV912AH, $T=25^\circ\text{C}$ TSV912AH, $T_{min} < T < T_{max}$			1.5 3	
$DV_{io}$	Input offset voltage drift	$-40^\circ\text{C} < T < +125^\circ\text{C}$ $+125^\circ\text{C} < T < +150^\circ\text{C}$		2 20		$\mu\text{V}/^\circ\text{C}$
$I_{io}$	Input offset current	$V_{out} = V_{CC}/2$ $T=25^\circ\text{C}$ $T_{min} < T < T_{max}$		1	$10^{(1)}$ 5	pA nA
$I_{ib}$	Input bias current	$V_{out} = V_{CC}/2$ $T=25^\circ\text{C}$ $T_{min} < T < T_{max}$		1	$10^{(1)}$ 5	pA nA
CMR	Common mode rejection ratio $20 \log (\Delta V_{ic}/\Delta V_{io})$	$0\text{V to } 5\text{V}$ , $V_{out} = 2.5\text{V}$ $T=25^\circ\text{C}$ $T_{min} < T < T_{max}$	62 58	82		dB
SVR	Supply voltage rejection ratio $20 \log (\Delta V_{CC}/\Delta V_{io})$	$V_{CC} = 2.5\text{ to } 5\text{V}$ $T=25^\circ\text{C}$ $T_{min} < T < T_{max}$	70 65	86		dB
$A_{vd}$	Large signal voltage gain	$R_L = 10\text{k}\Omega$ , $V_{out} = 0.5\text{V to } 4.5\text{V}$ $T=25^\circ\text{C}$ $T_{min} < T < T_{max}$	80 70	91		dB
$V_{CC}-V_{OH}$	High level output voltage	$R_L = 10\text{k}\Omega$ , $T=25^\circ\text{C}$ $R_L = 10\text{k}\Omega$ , $T_{min} < T < T_{max}$		15	40 60	mV
		$R_L = 600\Omega$ , $T=25^\circ\text{C}$ $R_L = 600\Omega$ , $T_{min} < T < T_{max}$		45	150 250	
$V_{OL}$	Low level output voltage	$R_L = 10\text{k}\Omega$ , $T=25^\circ\text{C}$ $R_L = 10\text{k}\Omega$ , $T_{min} < T < T_{max}$		15	40 60	mV
		$R_L = 600\Omega$ , $T=25^\circ\text{C}$ $R_L = 600\Omega$ , $T_{min} < T < T_{max}$		45	150 250	
$I_{out}$	$I_{sink}$	$V_{out} = 5\text{V}$ $T=25^\circ\text{C}$ $T_{min} < T_{op} < T_{max}$	18 14	32		mA
	$I_{source}$	$V_{out} = 0\text{V}$ $T=25^\circ\text{C}$ $T_{min} < T_{op} < T_{max}$	18 14	35		
$I_{CC}$	Supply current (per operator)	No load, $V_{out} = 2.5\text{V}$ $T=25^\circ\text{C}$ $T_{min} < T_{op} < T_{max}$		0.82	1.1 1.1	mA

**Table 5. Electrical characteristics at  $V_{CC+} = +5\text{ V}$  with  $V_{CC-} = 0\text{ V}$ ,  $V_{icm} = V_{CC}/2$ ,  $R_L$  connected to  $V_{CC}/2$ , full temperature range (unless otherwise specified) (continued)**

Symbol	Parameter	Conditions	Min.	Typ.	Max.	Unit
<b>AC performance</b>						
GBP	Gain bandwidth product	$R_L = 2\text{k}\Omega$ , $C_L = 100\text{pF}$ , $f = 100\text{kHz}$ $T = 25^\circ\text{C}$ $T_{\min} < T_{\text{op}} < T_{\max}$		8 4.5		MHz
$F_u$	Unity gain frequency	$R_L = 2\text{k}\Omega$ , $C_L = 100\text{pF}$		7.5		MHz
$\phi_m$	Phase margin	$R_L = 2\text{k}\Omega$ , $C_L = 100\text{pF}$		45		Degrees
$G_m$	Gain margin	$R_L = 2\text{k}\Omega$ , $C_L = 100\text{pF}$		8		dB
SR	Slew rate	$R_L = 2\text{k}\Omega$ , $C_L = 100\text{pF}$ , $A_V = 1$ $T = 25^\circ\text{C}$ $T_{\min} < T_{\text{op}} < T_{\max}$		4.5 3.5		V/ $\mu\text{s}$
$e_n$	Equivalent input noise voltage	$f = 1\text{kHz}$ $f = 10\text{kHz}$		27 21		$\frac{\text{nV}}{\sqrt{\text{Hz}}}$
THD+ $e_n$	Total harmonic distortion	$G = 1$ , $f = 1\text{kHz}$ , $R_L = 2\text{k}\Omega$ , $Bw = 22\text{kHz}$ , $V_{icm} = (V_{CC+} + 1)/2$ , $V_{\text{out}} = 3.6V_{\text{pp}}$		0.0004		%

1. Guaranteed by design.

Electrical characteristics

TSV912H, TSV912AH

Figure 1. Input offset voltage distribution at T = 25° C

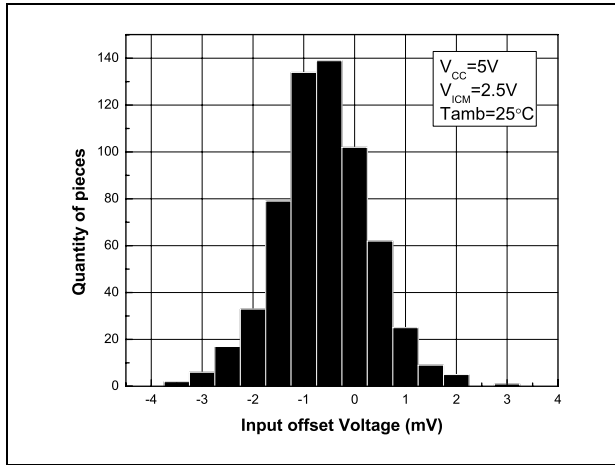

Figure 2. Input offset voltage distribution at T = 150° C

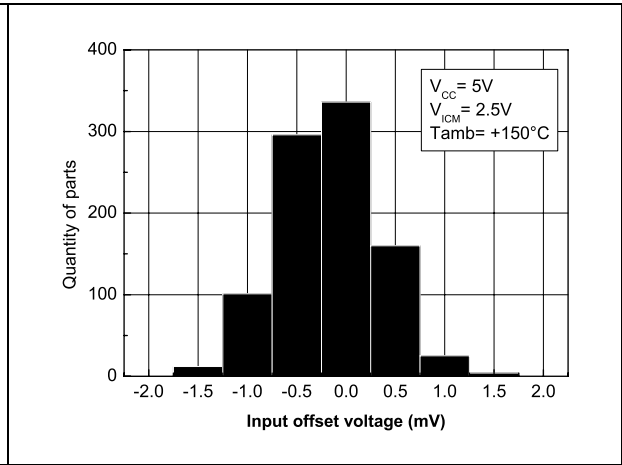

Figure 3. Supply current vs. input common-mode voltage at V<sub>CC</sub> = 2.5 V

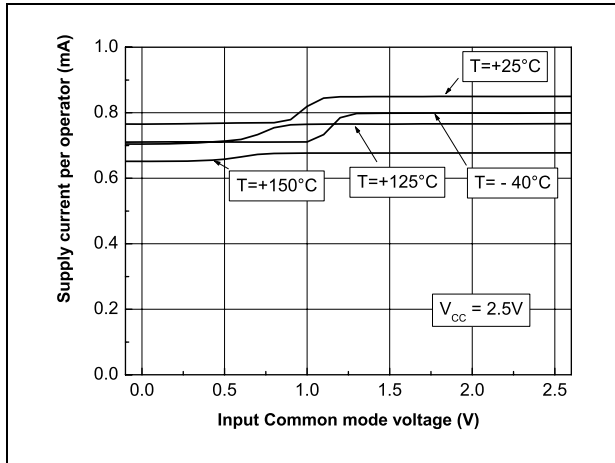

Figure 4. Supply current vs. input common-mode voltage at V<sub>CC</sub> = 5 V

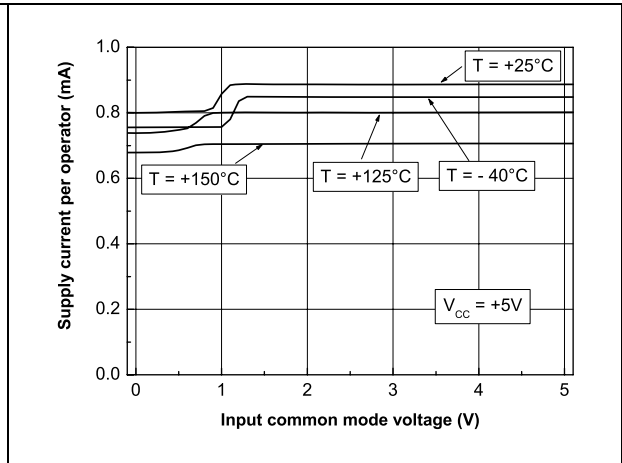

Figure 5. Output current vs. output voltage at V<sub>CC</sub> = 2.5 V

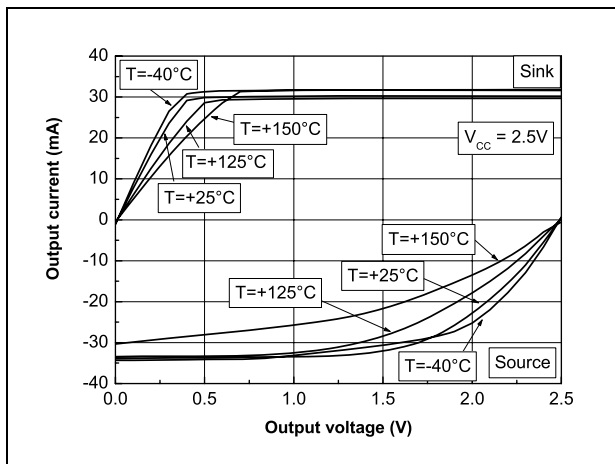
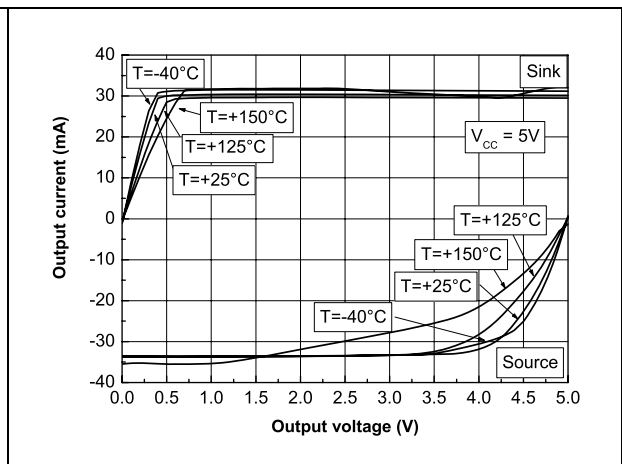
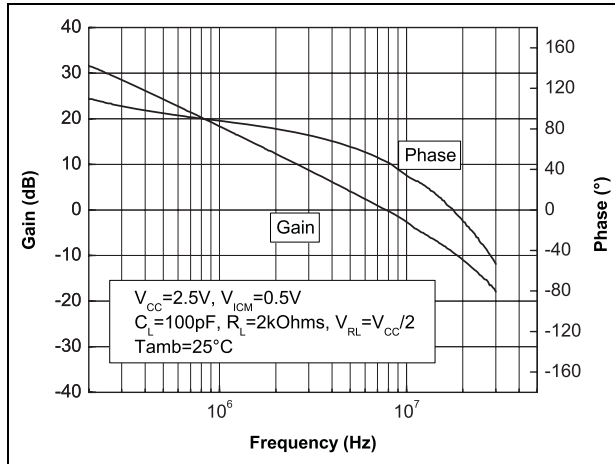

Figure 6. Output current vs. output voltage at V<sub>CC</sub> = 5 V

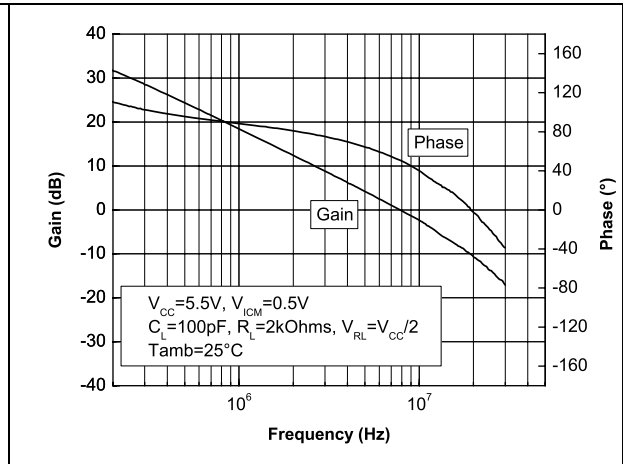



**Figure 7. Voltage gain and phase vs frequency at  $V_{CC} = 2.5\text{ V}$  and  $V_{icm} = 0.5\text{ V}$**



**Figure 8. Voltage gain and phase vs frequency at  $V_{CC} = 5.5\text{ V}$  and  $V_{icm} = 0.5\text{ V}$**



**Figure 9. Phase margin vs. capacitive load**

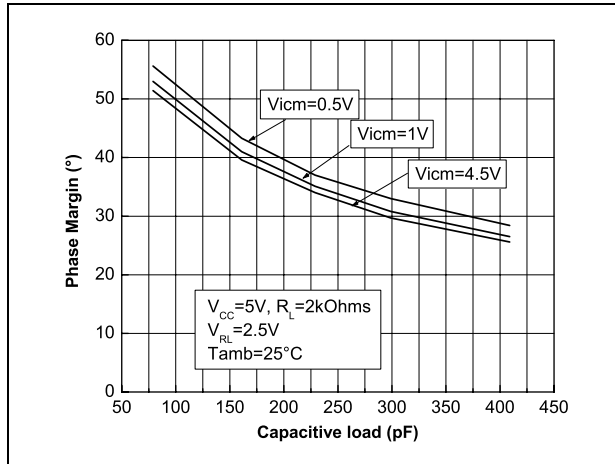

**Figure 10. Phase margin vs. output current**

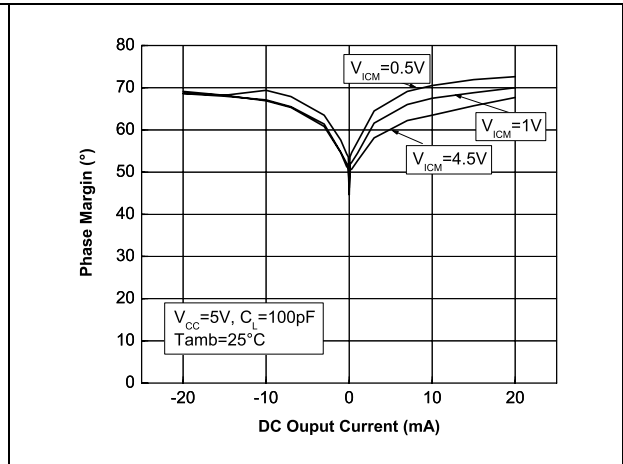

**Figure 11. Positive slew rate**

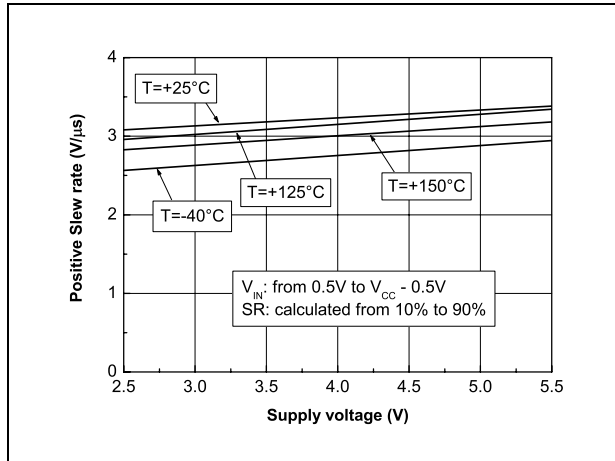

**Figure 12. Negative slew rate**

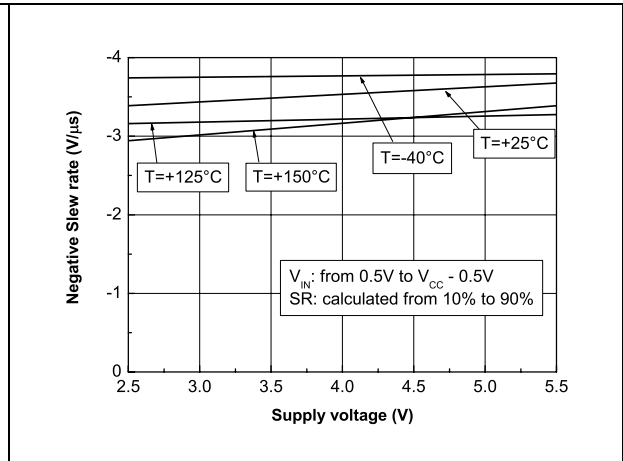

Figure 13. Distortion + noise vs. frequency

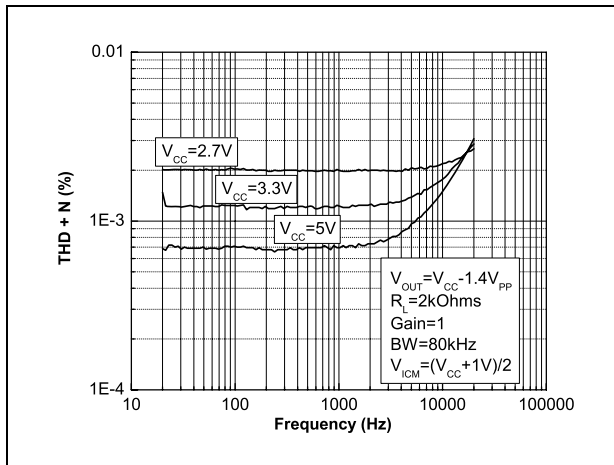

Figure 14. Distortion + noise vs. output voltage

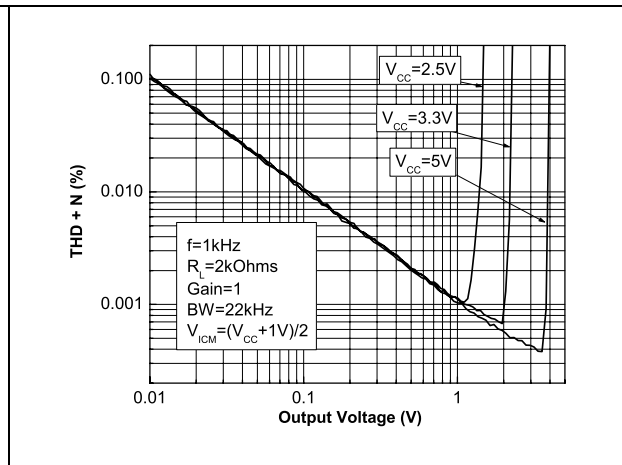

Figure 15. Noise vs. frequency

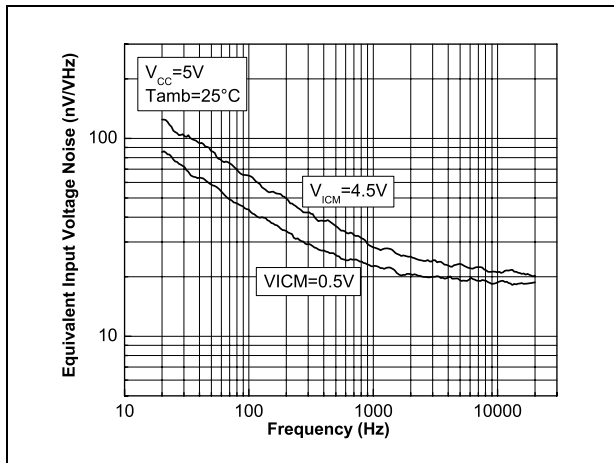

Figure 16. Phase margin vs. capacitive load and serial resistor

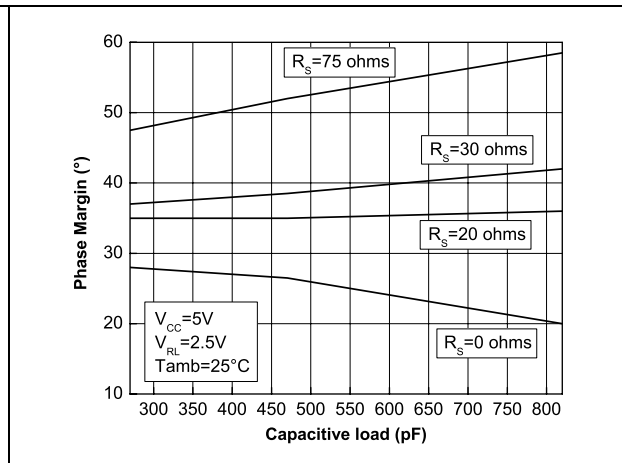
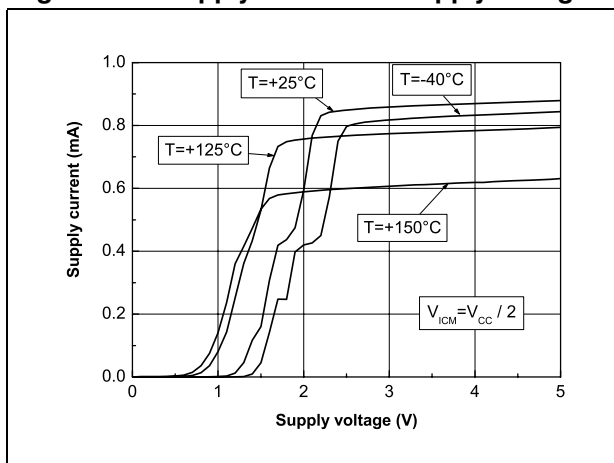

Figure 17. Supply current vs. supply voltage



## 3 Application information

### 3.1 Driving resistive and capacitive loads

These products are low-voltage, low-power operational amplifiers optimized to drive rather large resistive loads above 2 k $\Omega$

In a *follower* configuration, these operational amplifiers can drive capacitive loads up to 100 pF with no oscillations. When driving larger capacitive loads, adding a small in-series resistor at the output can improve the stability of the devices (see [Figure 18](#) for recommended in-series resistor values). Once the in-series resistor value has been selected, the stability of the circuit should be tested on bench and simulated with the simulation model.

**Figure 18. In-series resistor vs. capacitive load**

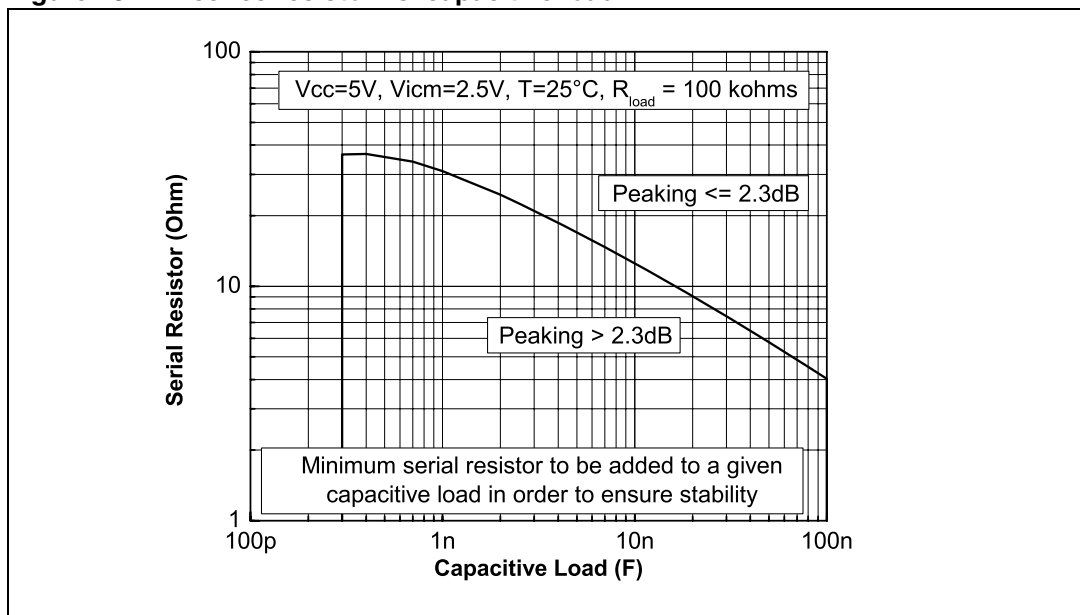

### 3.2 PCB layouts

For correct operation, it is advised to add 10 nF decoupling capacitors as close as possible to the power supply pins.

## 4 Package information

In order to meet environmental requirements, ST offers these devices in different grades of ECOPACK<sup>®</sup> packages, depending on their level of environmental compliance. ECOPACK<sup>®</sup> specifications, grade definitions and product status are available at: [www.st.com](http://www.st.com). ECOPACK<sup>®</sup> is an ST trademark.

## 4.1 SO-8 package information

Figure 19. SO-8 package mechanical drawing

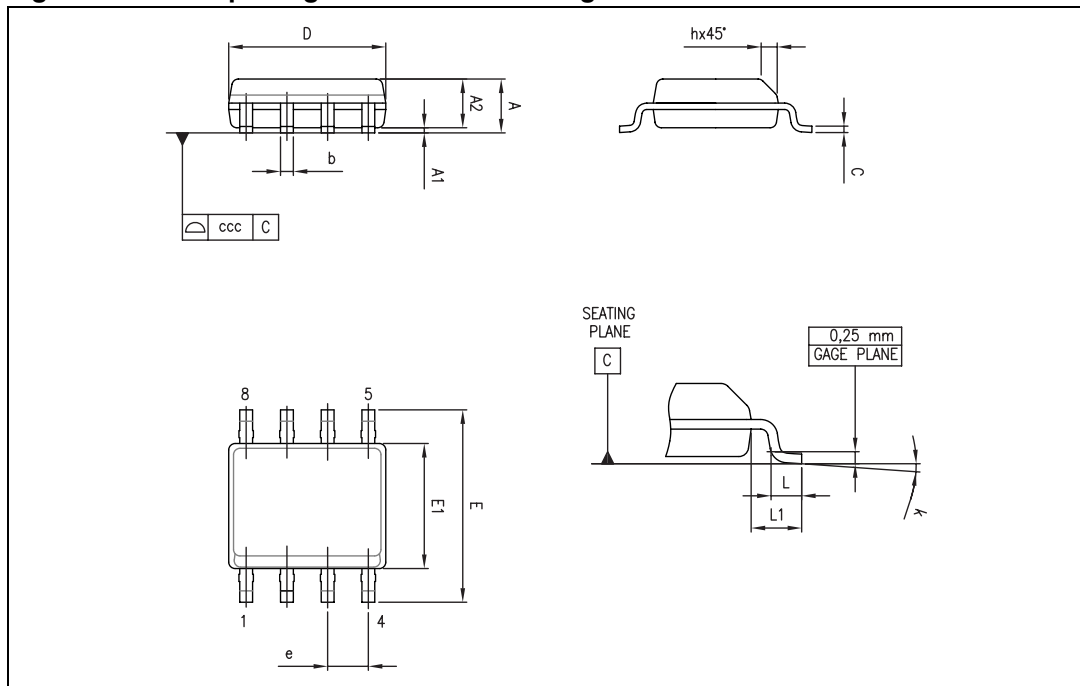

Table 6. SO-8 package mechanical data

Ref.	Dimensions					
	Millimeters			Inches		
	Min.	Typ.	Max.	Min.	Typ.	Max.
A			1.75			0.069
A1	0.10		0.25	0.004		0.010
A2	1.25			0.049		
b	0.28		0.48	0.011		0.019
c	0.17		0.23	0.007		0.010
D	4.80	4.90	5.00	0.189	0.193	0.197
E	5.80	6.00	6.20	0.228	0.236	0.244
E1	3.80	3.90	4.00	0.150	0.154	0.157
e		1.27			0.050	
h	0.25		0.50	0.010		0.020
L	0.40		1.27	0.016		0.050
L1		1.04			0.040	
k	0		8°	1°		8°
ccc			0.10			0.004

## 5 Ordering information

**Table 7. Order codes**

Order code	Temperature range	Package	Packing	Marking
TSV912HYDT <sup>(1)</sup>	-40°C to +150°C	SO-8 <sup>(2)</sup> (automotive grade level)	Tape & reel	V912HY
TSV912AHYDT <sup>(1)</sup>				V912AHY

1. Qualification and characterization according to AEC Q100 and Q003 or equivalent, advanced screening according to AEC Q001 & Q 002 or equivalent.
2. SO8 package is Moisture Sensitivity Level 1 as per Jedec J-STD-020-C.

## 6 Revision history

**Table 8. Document revision history**

Date	Revision	Changes
08-Jul-2010	1	Initial release.

**Please Read Carefully:**

Information in this document is provided solely in connection with ST products. STMicroelectronics NV and its subsidiaries ("ST") reserve the right to make changes, corrections, modifications or improvements, to this document, and the products and services described herein at any time, without notice.

All ST products are sold pursuant to ST's terms and conditions of sale.

Purchasers are solely responsible for the choice, selection and use of the ST products and services described herein, and ST assumes no liability whatsoever relating to the choice, selection or use of the ST products and services described herein.

No license, express or implied, by estoppel or otherwise, to any intellectual property rights is granted under this document. If any part of this document refers to any third party products or services it shall not be deemed a license grant by ST for the use of such third party products or services, or any intellectual property contained therein or considered as a warranty covering the use in any manner whatsoever of such third party products or services or any intellectual property contained therein.

**UNLESS OTHERWISE SET FORTH IN ST'S TERMS AND CONDITIONS OF SALE ST DISCLAIMS ANY EXPRESS OR IMPLIED WARRANTY WITH RESPECT TO THE USE AND/OR SALE OF ST PRODUCTS INCLUDING WITHOUT LIMITATION IMPLIED WARRANTIES OF MERCHANTABILITY, FITNESS FOR A PARTICULAR PURPOSE (AND THEIR EQUIVALENTS UNDER THE LAWS OF ANY JURISDICTION), OR INFRINGEMENT OF ANY PATENT, COPYRIGHT OR OTHER INTELLECTUAL PROPERTY RIGHT.**

**UNLESS EXPRESSLY APPROVED IN WRITING BY AN AUTHORIZED ST REPRESENTATIVE, ST PRODUCTS ARE NOT RECOMMENDED, AUTHORIZED OR WARRANTED FOR USE IN MILITARY, AIR CRAFT, SPACE, LIFE SAVING, OR LIFE SUSTAINING APPLICATIONS, NOR IN PRODUCTS OR SYSTEMS WHERE FAILURE OR MALFUNCTION MAY RESULT IN PERSONAL INJURY, DEATH, OR SEVERE PROPERTY OR ENVIRONMENTAL DAMAGE. ST PRODUCTS WHICH ARE NOT SPECIFIED AS "AUTOMOTIVE GRADE" MAY ONLY BE USED IN AUTOMOTIVE APPLICATIONS AT USER'S OWN RISK.**

Resale of ST products with provisions different from the statements and/or technical features set forth in this document shall immediately void any warranty granted by ST for the ST product or service described herein and shall not create or extend in any manner whatsoever, any liability of ST.

ST and the ST logo are trademarks or registered trademarks of ST in various countries.

Information in this document supersedes and replaces all information previously supplied.

The ST logo is a registered trademark of STMicroelectronics. All other names are the property of their respective owners.

© 2010 STMicroelectronics - All rights reserved

STMicroelectronics group of companies

Australia - Belgium - Brazil - Canada - China - Czech Republic - Finland - France - Germany - Hong Kong - India - Israel - Italy - Japan - Malaysia - Malta - Morocco - Philippines - Singapore - Spain - Sweden - Switzerland - United Kingdom - United States of America

[www.st.com](http://www.st.com)