

QL80FC - QuickFC™



QuickLogic QL80FC Programmable Fibre Channel ENDEC

FEATURES

- ANSI Fibre Channel (FC) compatibility
- Data rates up to 2.5 Gb/s supported
- 2.5Gb/s Simplex (200 MByte/s) or Duplex (400 MByte/s) Mode
- Compatible with standard SERDES components
- 32 bit synchronous FIFO system interface
- Tx and Rx internal FIFO for system applications without external FIFOs
- Selectable 20-bit/10-bit encoded transmission character interface to SERDES
- 8b/10b Encoding/Decoding
- CRC Calculation and checking per FC standard
- Fibre Channel Loss of Synchronization (LOS) state machine
- Support for arbitrated loops
- IntraFrame idles support for proprietary links
- “Raw” data path for the injection of encoding and CRC errors into the bitstream for use in testing link error handling functions
- 3.3V operating voltage
- 3.3V CMOS I/O, 5.0V CMOS tolerant inputs
- 208 PQFP and 456 PBGA packages available

EXTENDED FEATURES

Extended features that can be designed into the user customizable logic:

- Fibre Channel Link Control State Machine (LCSM)
- RRDY credit management for link flow control
- Microprocessor interface to configure various link modes
- BIST functions support link bit error rate measurements

DUAL PORT SRAM

- 22 blocks (total of 25,344 bits) of dual-port RAM
- Configurable as RAM, ROM or FIFO
- Can be configured as two internal FIFOs of up to 352 x 36 in size
- Configurable RAM array sizes (by 2, 4, 9, 18)
- <5ns access times, 160+Mhz FIFOs

HIGH SPEED CUSTOMIZABLE LOGIC

- Up to 269 customizable I/O pins
- 751 Logic cells
- 300 MHz 16-bit counters, 400 MHz Data paths
- Mux-Based architecture; non-volatile technology
- Completely customizable for any digital application

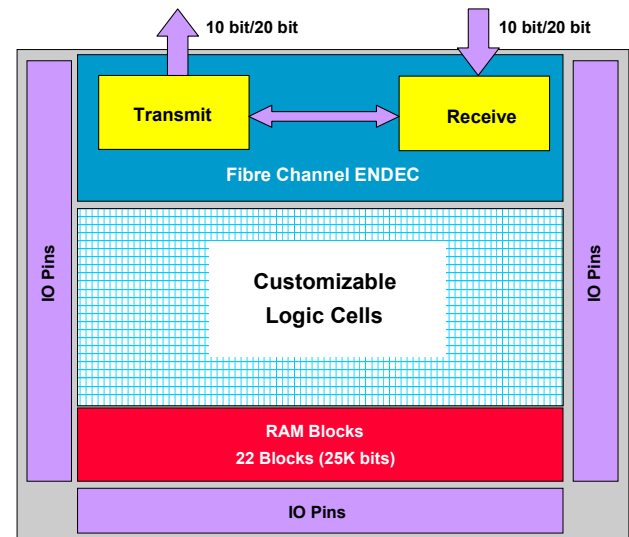

Fibre Channel Block Diagram



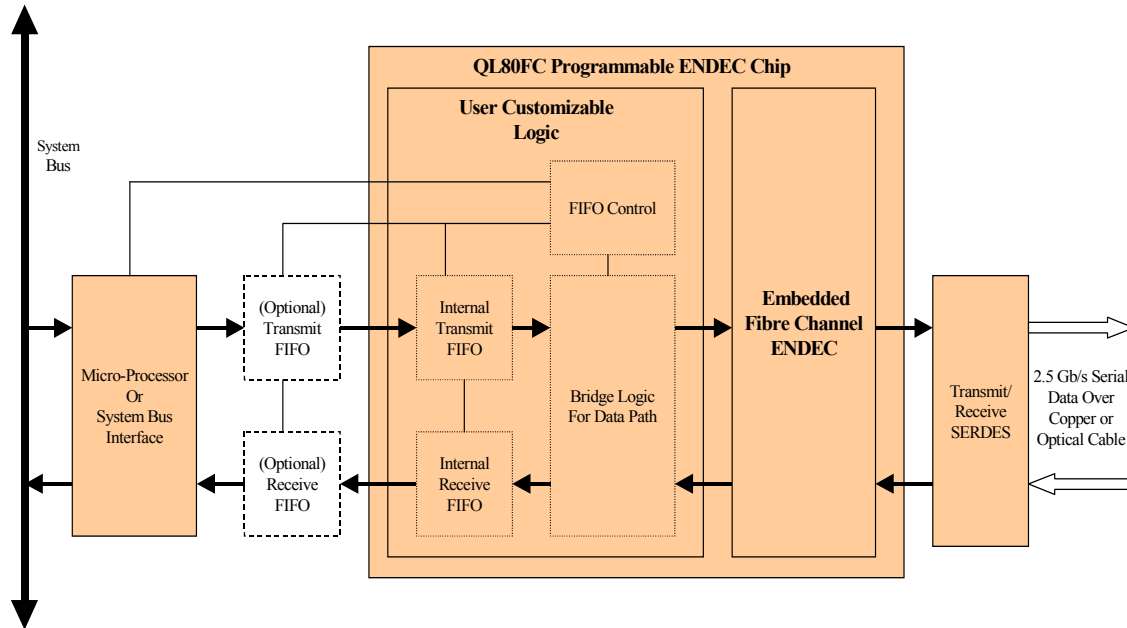

FIGURE 1. System Level Diagram

GENERAL DESCRIPTION

The QL80FC device in the QuickLogic QuickFC ESP (Embedded Standard Product) family provides a completely integrated configurable Fibre Channel Encoder/Decoder interface solution combined with customizable logic. This device provides a means to receive and transmit high-speed serial data and implement a Fibre Channel Link interface or any proprietary high-speed serial link.

The chip is divided into two main portions, an embedded design and a customizable design. The embedded design contains the built in functionality of Fibre Channel's FC-1 and FC-2 layers, which the system designer uses as a standard product. This portion can not be modified. As such, all functionality and timing requirements have been verified in hardware and are guaranteed.

The customizable portion consists of user customizable system gates, and interfaces directly to the embedded portion of the chip. These gates may be programmed to implement glue logic to other bus standards such as PCI or SCSI. They can also be programmed with Fibre Channel Upper Layer Protocols. Of course, the designer may choose to modify Upper Layer Protocols for customization. In this way, the

QuickLogic QL80FC provides the embedded systems designer with an easy to use and cost effective solution for embedded serial applications.

FIBRE CHANNEL APPLICATIONS

The QL80FC ENDEC is a high performance encoder/decoder designed for use in conjunction with Gb/s SERDES transmitter/receiver chips. These chips, when combined with internal FIFO buffer memory, can be used to build a complete serial link. Optional, external FIFOs can be used in place of the available internal FIFOs to extend buffering to sizes beyond 352 words.

The embedded ENDEC is a full duplex design with an encoder section for transmission and a decoder section for reception. The transmitter/encoder section accepts a 4-byte user data word, encodes each byte into a 10-bit transmission character and outputs transmission characters to the SERDES transmitter. This equals two 10-bit characters per clock (one 10-bit character per clock in 10-bit mode). The receiver/decoder section accepts two 10-bit transmission char-

QL80FC - QuickFC™

acters from the SERDES receiver (one 10-bit character in 10-bit mode), decodes them, and outputs a 4-byte user data word.

The QL80FC has a system interface that emulates a synchronous FIFO for ease of use. FIFOs allow maximum sustained performance of 400 MB/s running a full duplex link. Their function is to handle the asynchronous interface between the bus data rate and the different serial data rates, and handle phase and frequency differences inherent in serial links. Internal FIFOs of 352 x 36 or external FIFOs can be used to expand the buffering to accommodate multiple frames.

The QL80FC includes the hardware necessary for packetized data protection. Framing functions are provided via Fibre Channel compliant command words (ordered sets) for Start of Frame and End of Frame. CRC generation and data frame verification protect the Fibre Channel frame header and data field when these framing functions are used.

The device provides a microprocessor interface that allows the user to manage the serial link. Signals are also provided to decode serial link error conditions and differentiate between data and commands. The QL80FC implements link synchronization with the

SERDES chip through the Loss of Synchronization State Machine (LOS) as required by the ANSI FC-PH specification. The LOS manages receiver word synchronization with the RxComDet (comma detect) signal.

The QL80FC is a versatile part that allows the system designer to create proprietary or Fibre Channel compliant serial links by taking advantage of some, or all, of the Fibre Channel compliant features. It has a number of useful features for system designers of proprietary links. One such feature is the ability to send intraframe IDLEs. These characters are automatically sent if the FIFO is empty, but they do not affect the CRC. In this mode the QL80FC allows simple interfacing to systems where the flow of data may be interrupted.

EMBEDDED DESIGN FUNCTIONAL DESCRIPTION

The embedded FC-1 and FC-2 layers are divided into two functional groupings: the Transmit data path and the Receive data path. A functional diagram for the Transmit path is included in Figure 2.

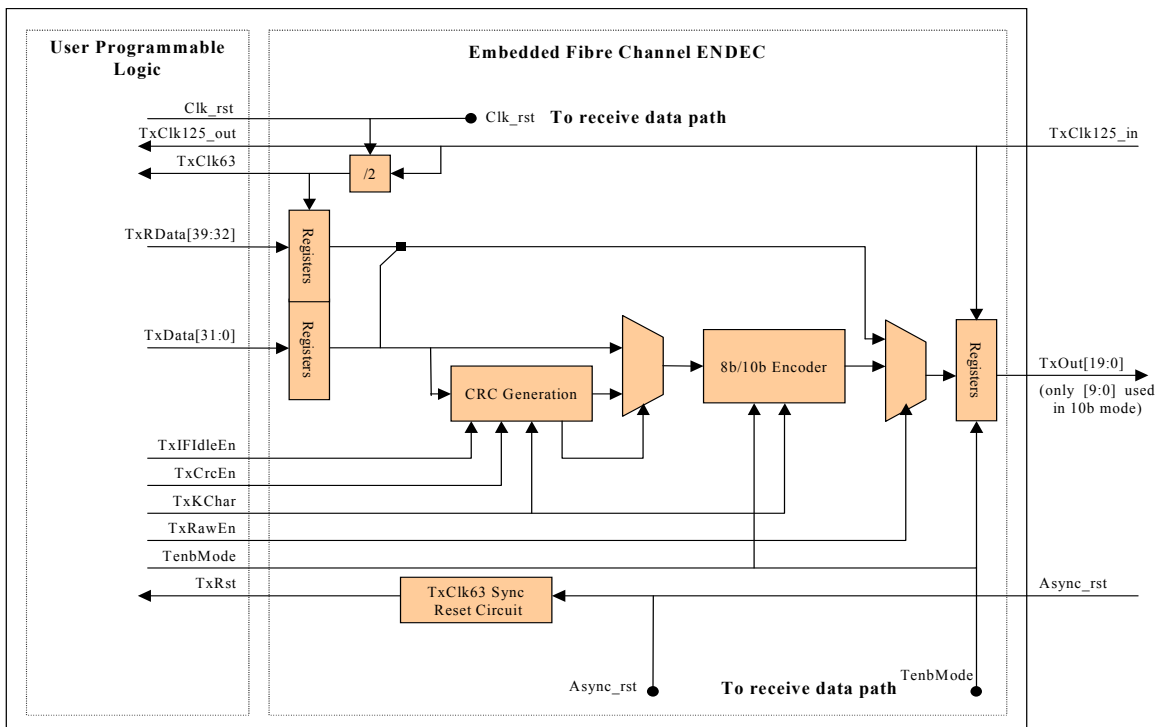

FIGURE 2. Customizable ENDEC Chip Functional Block Diagram - Transmit and LCSM Data Paths

TRANSMIT DATA PATH

When the transmit data path is in standard operation (TxRawEn not asserted) the chip will latch an un-encoded, Fibre Channel, 32-bit word on inputs TxData[31:0]. This data then passes on to the 8b/10b encoder, which creates a 40-bit encoded Fibre Channel word. The encoder will encode the most significant character as a command character if the TxKChar input line is asserted. This word is registered and passed to the SERDES in 20-bit chunks (10 bit chunks if 10 bit mode is enabled) on the TxOut signal lines.

Asserting the TxCrcEn signal enables the CRC Generation block. This block will automatically detect the SOF ordered set and begin CRC generation using the ANSI specified CRC polynomial. It will continue until an EOF or any other FC ordered set is encountered (unless TxIFIdleEn is asserted, then the IDLE ordered set will be ignored by the CRC generator). It then inserts the CRC value into the data path for transmission to the SERDES.

The TxRawEn signal enables the raw transmit data path when asserted. In this mode, the 8 bits of TxRData is concatenated onto the 32 bits of the TxData signal to create a 40-bit wide data path. The CRC generation and 8b/10b encoder blocks are bypassed and the “raw” data latched at the inputs is passed directly to the output registers that drive the SERDES. This mode is useful for testing the error handling capabilities of the serial link by providing the systems designer a way to intentionally introduce errors into the serial bit stream.

The TxIFIdleEn (Intra-Frame Idle Enable) input enables the use of Fibre Channel IDLE words within a Frame. When this signal is asserted, IDLE words present within a data frame will not affect the value

generated by the CRC block. This feature is useful in custom FC designs where it is desired to suspend the transmission of a frame for a period of time and then resume later.

The use of external FIFOs is optional. There is enough RAM on the ENDEC chip to be configured into two 352 x 36 FIFOs. If FIFOs of this size are all that is required, external FIFOs would not be needed. Synchronous read and writes directly from the system bus without a FIFO is also possible.

Two clock signals are supplied to the customizable logic on high speed, low skew clock networks: TxClk125 and TxClk63. TxClk125 is a clock running at a maximum speed of 125 MHz, and represents the “full speed” of the Oscillator being used to clock the transmit data path. The input that drives this signal is also used to clock the SERDES chip. The TxClk63 clock signal operates at half the speed of the TxClk125 clock. You will most likely want to use the TxClk63 signal to clock your FIFOs and customizable logic. Of course, these signals can be routed off-chip through the customizable I/O.

The Async_rst pin accepts an asynchronous, active high reset signal. Circuitry takes this signal and synchronizes it with the TxClk63 clock. This synchronous reset signal, TxRst, is used to set or clear flip-flops in the transmit data path. It is made available to the user programmable logic for the same purpose on a high speed, low skew network.

The Clk_rst input stops the TxClk63 clock when this signal is asserted. This signal was added primarily to facilitate simulation. Clk_rst may be permanently grounded in hardware.

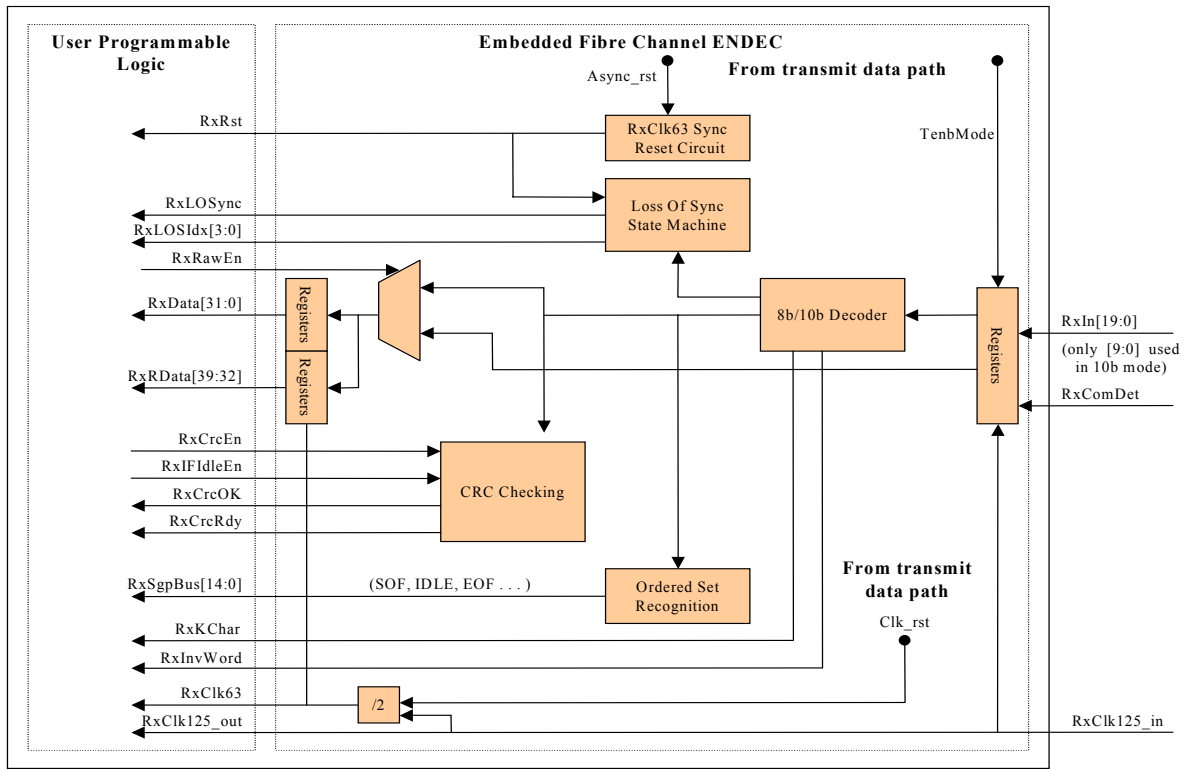

FIGURE 3. Customizable ENDEC Chip Functional Block Diagram - Receive Data Path

RECEIVE DATA PATH

The receive data path receives encoded data from an on-board SERDES, decodes it and passes the resulting data to the customizable section of the chip. A functional block diagram of the receive data path is shown in Figure 3.

The RxClk125 signal latches 20 bits (10 bits when 10-bit mode is enabled) of data from the SERDES into the RxIn input registers on the positive edge of the clock. The RxClk125 signal is made available to the customizable section. RxClk125 is divided by two and made available to the customizable section on the RxClk63 signal line. Both clocks use a high speed, low skew clock network. Again you will most likely want to use the RxClk63 signal to clock all registers and FIFOs in the receive data path. Registers using RxClk125 and RxClk63 should be sensitive to the rising edge of these clocks.

Once the data on the RxIn signal lines is latched into the input registers, the data is passed on to the 8b/10b decoder. Under standard operation, (input RxRa-

wEn is low), the data is decoded into 4, 8-bit characters and the resulting Fibre Channel word is placed on the RxData[31:0] output signals. RxRData is not used under normal operation. If the decoder detects a Fibre Channel comma character in the most significant character of the word, the RxKChar signal line will be asserted.

When the Rx_crcEn signal is asserted the CRC checking logic will function. The CRC logic will automatically detect a SOF word and begin performing CRC division on the next word in the data stream using the ANSI specified CRC polynomial for Fibre Channel. When an EOF word or any other FC ordered set is detected (unless RxIFIdleEn is asserted, then the IDLE ordered set will be ignored by the CRC checker) the CRC will assert the Rx_crcRdy signal for one cycle of the RxClk63 clock. If the remainder for the division is zero, the Rx_crcOK signal line will also be asserted during this same cycle.

When the RxRawEn signal is asserted the “raw” data path will be enabled for the receive circuit. With the “raw” data path enabled, the data received from the SERDES does not pass through the 8b/10b decoder or the CRC checking blocks. Instead it is routed directly to the output registers and is made available to the customizable section of the chip on signal lines RxRData and RxData. This mode is useful for testing the serial link.

The Loss of Synchronization State machine is responsible for achieving character synchronization on the data being sent from the SERDES. When the Rst signal is asserted, the LOSSM goes to the “loss of synchronization” state. In this state the RxLOSync signal will be asserted. After the reception of three valid command characters, the state machine will proceed to the “synchronization acquired” state and the RxLOSync signal is de-asserted. After the reception of 4 successive invalid characters the state machine will return to the “Loss of Synchronization” state. The value on the RxLOSIdx bus indicates the state of LOSSM.

The ordered set recognition block detects Fibre Channel ordered sets and asserts one signal line in

the RxSgpBus bus corresponding to the ordered set detected. All 15 Fibre Channel ordered set types are detected including SOF, EOF and IDLE. There is a list of ordered sets detected by the ordered set recognition circuitry in Table 1.

There are two signals used to indicate that a word having a decoding error of some kind is present on the RxData outputs. When RxInvChar is asserted a word with an invalid 10-bit representation is present on the RxData signal lines. RxRDErr indicates an invalid running disparity was detected on the currently available RxData word.

The Async_rst pin accepts an asynchronous, active high reset signal. Circuitry takes this signal and synchronizes it with the RxClk63 clock. This synchronous reset signal, RxRst, is used to set or clear flip-flops in the receive data path. It is made available to the user programmable logic for the same purpose on a high speed, low skew network.

The Clk_rst input stops the RxClk63 clock when this signal is asserted. This signal was added primarily to facilitate simulation. Clk_rst may be permanently grounded in hardware.

RECOGNIZED ORDERED SETS

| Beginning RD | Identifier | Ordered Set Code | Hex Equivalent | RxSgpBus Signal Line Asserted |
|--------------|------------|-------------------------|----------------|-------------------------------|
| - | SOFc1 | K28.5 D21.5 D23.0 D23.0 | BC B5 17 17 | [0] |
| - | SOFi1 | K28.5 D21.5 D23.2 D23.2 | BC B5 57 57 | [0] |
| - | SOFn1 | K28.5 D21.5 D23.1 D23.1 | BC B5 37 37 | [0] |
| - | SOFi2 | K28.5 D21.5 D21.2 D21.1 | BC B5 55 55 | [0] |
| - | SOFn2 | K28.5 D21.5 D21.1 D21.1 | BC B5 35 35 | [0] |
| - | SOFi3 | K28.5 D21.5 D22.2 D22.2 | BC B5 56 56 | [0] |
| - | SOFn3 | K28.5 D21.5 D22.1 D22.1 | BC B5 36 36 | [0] |
| - | SOFf | K28.5 D21.5 D24.2 D24.2 | BC B5 58 58 | [0] |
| - | EOFt | K28.5 D21.4 D21.3 D21.3 | BC 95 75 75 | [1] |
| + | EOFt | K28.5 D21.5 D21.3 D21.3 | BC B5 75 75 | [1] |
| - | EOFdt | K28.5 D21.4 D21.4 D21.4 | BC 95 95 95 | [1] |
| + | EOFdt | K28.5 D21.5 D21.4 D21.4 | BC B5 95 95 | [1] |
| - | EOFa | K28.5 D21.4 D21.7 D21.7 | BC 95 F5 F5 | [1] |
| + | EOFa | K28.5 D21.5 D21.7 D21.7 | BC B5 F5 F5 | [1] |
| - | EOFn | K28.5 D21.4 D21.6 D21.6 | BC 95 D5 D5 | [1] |
| + | EOFn | K28.5 D21.5 D21.6 D21.6 | BC B5 D5 D5 | [1] |
| - | EOFdti | K28.5 D10.4 D21.4 D21.4 | BC 8A 95 95 | [1] |
| + | EOFdti | K28.5 D10.5 D21.4 D21.4 | BC AA 95 95 | [1] |
| - | EOFni | K28.5 D10.4 D21.6 D21.6 | BC 8A D5 D5 | [1] |
| + | EOFni | K28.5 D10.5 D21.6 D21.6 | BC AA D5 D5 | [1] |
| - | IDLE | K28.5 D21.4 D21.5 D21.5 | BC 95 B5 B5 | [2] |
| + | IDLE* | K28.5 D21.5 D21.5 D21.5 | BC B5 B5 B5 | [2] |
| - | R_RDY | K28.5 D21.4 D10.2 D10.2 | BC 95 4A 4A | [3] |
| - | OLS | K28.5 K21.1 D10.4 D21.2 | BC 35 8A 55 | [4] |
| - | NOS | K28.5 D21.2 D31.5 D5.2 | BC 55 BF 45 | [5] |
| - | LR | K28.5 D9.2 D31.5 D9.2 | BC 49 BF 49 | [6] |
| - | LRR | K28.5 D21.1 D31.5 D9.2 | BC 35 BF 49 | [7] |
| - | ARBx | K28.5 D20.4 AL PA AL PA | BC 4A xx xx | [8] |
| - | ARB(F0) | K28.4 D20.4 D16.7 D16.7 | BC 4A F0 F0 | [8] |
| - | OPNyx | K28.5 D17.4 AL PD AL PS | BC 91 yy xx | [9] |
| - | OPNyy | K28.5 D17.4 AL PD AL PD | BC 91 yy yy | [9] |
| - | OPNfr | K28.5 D17.4 D31.7 D31.7 | BC 91 FF FF | [9] |
| - | OPNyr | K28.5 D17.4 AL PD D31.7 | BC 91 yy FF | [9] |
| - | CLS | K28.5 D5.4 D21.5 D21.5 | BC 85 B5 B5 | [10] |
| - | MRKtx | K28.5 D31.2 MK TP AL PS | BC 5F tt xx | [11] |
| - | LIP(F7,F7) | K28.5 D21.0 D23.7 D23.7 | BC 15 F7 F7 | [12] |
| - | LIP(F8,F7) | K28.5 D21.0 D24.7 D23.7 | BC 15 F8 F7 | [12] |
| - | LIP(F7,x) | K28.5 D21.0 D23.7 AL PS | BC 15 F7 xx | [12] |
| - | LIP(F8,x) | K28.5 D21.0 D24.7 AL PS | BC 15 F8 xx | [12] |
| - | LIP(y,x) | K28.5 D21.0 AL PD AL PS | BC 15 yy xx | [12] |
| - | LPEyx | K28.5 D5.0 AL PD AL PS | BC 05 yy xx | [13] |
| - | LPEfx | K28.5 D5.0 D31.7 AL PS | BC 05 FF xx | [13] |
| - | LPByx | K28.5 D9.0 AL PD AL PS | BC 09 yy xx | [14] |

TABLE 1. Table of Recognized Ordered Sets

* Only recognized when RxIFIdleEn is asserted

SIGNAL DEFINITIONS

Dedicated I/O Pins

| | | |
|-------------|--------|---|
| Async rst | input | active high, asynchronous reset |
| TxOut[19:0] | output | data transmitted to SERDES (only lines [9:0] are used in 10 bit mode) |
| TxCk125 in | input | transmit clock up to 125 MHz |
| RxIn[19:0] | input | data received from SERDES |
| RxCk125 in | input | receive clock up to 125 MHz |
| RxComDet | input | Fibre Channel comma character detected |
| ResIn[2:0] | input | reserved for QuickLogic use, hold low or high |

Customizable Interface Signals

| | | |
|----------------|--------|--|
| TenbMode | input | enables 10 bit interface to SERDES when asserted |
| Clk rst | Input | Stops TxClk63 and RxClk63 when high. Tie Low. |
| TxRst | output | active high reset signal for transmit path, synchronous with TxClk63 |
| TxData[31:0] | input | 32 bit Fibre Channel word to be encoded for transmit path |
| TxRData[39:32] | input | only used when TxRawEn is asserted. Combines with TxData to construct 40 bit raw data for transmit path |
| TxCrcEn | input | enables CRC error value generation when asserted |
| TxIFIdleEn | Input | enables Intra-Frame IDLE support for transmit path when asserted |
| TxRawEn | input | select between raw and encoded data modes for transmit data path |
| TxKChar | input | indicates that the most significant byte of data word is a K character |
| TxCk125 | output | full speed transmit clock up to 125 MHz (use the rising edge) |
| TxCk63 | output | half speed transmit clock up to 63 MHz (use the rising edge) |
| RxData[31:0] | output | 32 bit Fibre Channel word decoded by the ENDEC receive path. |
| RxRData[39:32] | output | only used when RxRawEn is asserted. Combines with RxData to construct 40 bit raw data through the ENDEC receive path |
| RxRawEn | input | select between raw and encoded data modes for receive data path |
| RxKChar | output | asserted when most significant byte of data word is a K character |
| RxSgpBus[14:0] | output | bus indicating when an ordered set is detected. One signal line is asserted corresponding to the type of ordered set detected: [0] – SOF [5] – NOS [10] – CLS [1] – EOF [6] – LR [11] – MRK [2] – IDLE [7] – LRR [12] – LIP [3] – R_RDY [8] – ARB [13] – LPE [4] – OLS [9] – OPN [14] – LPB |
| RxCrcRdy | output | asserted when available data is a CRC word |
| RxCrcOK | output | asserted when CRC remainder is zero |
| RxCrcEn | input | enables CRC error checking for the receive data path when asserted |
| RxIFIdleEn | input | enables Intra-Frame IDLE support for receive path when asserted |
| RxLOSync | output | asserted when bit synchronization with the SERDES has been lost |
| RxLOSIdx[3:0] | output | index indicating state of Loss of Sync state machine |
| RxInvChar | output | asserted when available data has an invalid encoding error |
| RxCk125 | output | full speed receive clock up to 125 MHz (use the rising edge) |
| RxCk63 | output | half speed receive clock up to 63 MHz (use the rising edge) |
| RxRst | output | active high reset signal for receive data path, synchronous with RxClk63 |
| ResOut[2:0] | output | reserved for QuickLogic use, do not connect to these outputs |

ARRAY OF LOGIC CELLS

A wide range of additional features complements the QL80FC device. The FPGA portion of the device is 5-volt and 3.3-volt compliant and can perform high-speed logic functions such as 160 MHz FIFOs. I/O pins provide individually controlled output enables, dedicated input/feedback registers, and full JTAG capability for boundary scan and test. In addition, the QL80FC device provides the benefits of non-volatility, high design security, immediate functionality on power-up, and a single chip solution.

The QL80FC customizable logic architecture consists of an array of user-configurable logic building blocks, called logic cells, set beneath a grid of metal wiring channels similar to those of a gate array. Through ViaLink® elements located at the wire intersections, the output(s) of any cell may be programmed to connect to the input(s) of any other cell. Using the customizable logic in the QL80FC, designers can quickly and easily customize their “back-end” design for any number of applications.

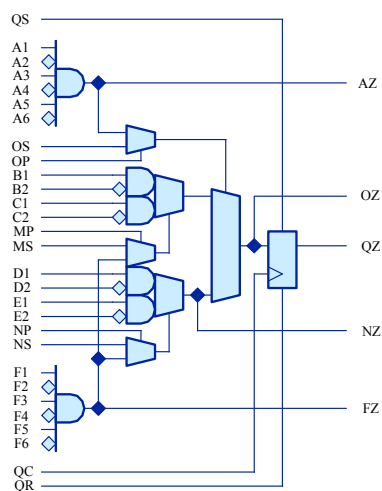

FIGURE 4. Logic Cell

RAM MODULE FEATURES

The QL80FC device has 22 1,152-bit RAM modules, for a total of 25,344 RAM bits. Using two “mode” pins, designers can configure each module into 64 (deep) x18 (wide), 128x9, 256x4, or 512x2 blocks. See the table below. The blocks are also easily cascadable to increase their effective width or depth.

| Mode: | Address Buses [a:0] | Data Buses [w:0] |
|--------------|----------------------------|-------------------------|
| 64x18 | [5:0] | [17:0] |
| 128x9 | [6:0] | [8:0] |
| 256x4 | [7:0] | [3:0] |
| 512x2 | [8:0] | [1:0] |

The RAM modules are “dual-ported”, with completely independent READ and WRITE ports and separate READ and WRITE clocks. The READ ports support asynchronous and synchronous operation, while the WRITE ports support synchronous operation. Each port has 18 data lines and 9 address lines, allowing word lengths of up to 18 bits and address spaces of up to 512 words. Depending on the mode selected, however, some higher order data or address lines may not be used.

The Write Enable (WE) line acts as a clock enable for synchronous write operation. The Read Enable (RE) acts as a clock enable for synchronous READ operation (ASYNCRD input low), or as a flow-through enable for asynchronous READ operation (ASYNCRD input high).

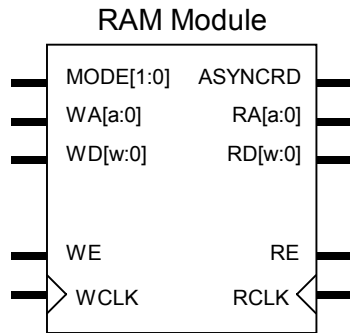

FIGURE 5. RAM Module

Designers can cascade multiple RAM modules to increase the depth or width allowed in single modules by connecting corresponding address lines together and dividing the words between modules. This approach allows up to 512-deep configurations as large as 16 bits wide in the QL80FC device.

A similar technique can be used to create depths greater than 512 words. In this case, address signals higher than the eighth bit are encoded onto the write enable (WE) input for WRITE operations. The READ data outputs are multiplexed together using encoded higher READ address bits for the multiplexer SELECT signals.

JTAG SUPPORT

JTAG pins support IEEE standard 1149.1a to provide boundary scan capability for the QL80FC device. Six pins are dedicated to JTAG and programming functions on each QL80FC device, and are unavailable for general design input and output sig-

nals. TDI, TDO, TCK, TMS, and TRSTB are JTAG pins. A sixth pin, STM, is used only for programming.

DEVELOPMENT TOOLS

Software support for the QL80FC device is available through the QuickWorks™ development package. This turnkey PC-based QuickWorks package, shown in Figure 6, provides a complete ESP software solution with design entry, logic synthesis, place and route, and simulation. QuickWorks includes VHDL, Verilog, schematic, and mixed-mode entry with fast and efficient logic synthesis provided by the integrated Synplicity Synplify Lite™ tool, specially tuned to take advantage of the QL80FC architecture. QuickWorks also provides functional and timing simulation for guaranteed timing and source-level debugging.

The UNIX-based QuickTools™ package is a subset of QuickWorks and provides a solution for designers who use schematic-only design flow or third-party tools for design entry, synthesis, or simulation.

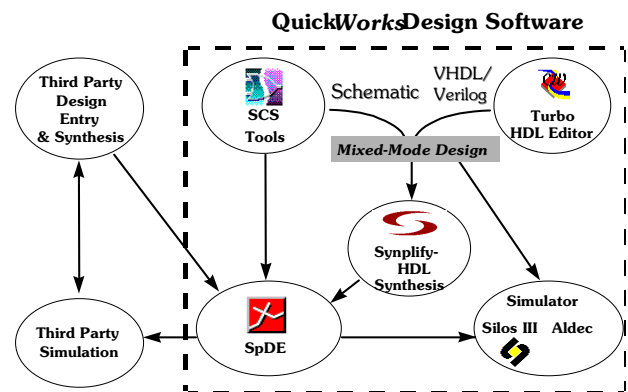

FIGURE 6. QuickWorks Tool Suite

QL80FC EXTERNAL DEVICE PINS

| Type | Description | Pin/Bus Name | Type | Function |
|--------------|---|-------------------|------------|---|
| IN | Input. A standard input-only signal. | VCC | IN | Supply pin. Tie to 3.3V supply. |
| OUT | Totem pole output. A standard active output driver. | VCCIO | IN | Supply pin for I/O. Set to 3.3V for 3.3V I/O, 5V for 5.0V compliant I/O. |
| T/S | Tri-state. A bi-directional, tri-state input/output pin. | GND | IN | Ground pin. Tie to GND on the PCB. |
| S/T/S | Sustained Tri-state. An active low tri-state signal driven by one PCI agent at a time. It must be driven high for at least one clock before being disabled (set to Hi-Z). A pull-up needs to be provided by the PCI system central resource to sustain the inactive state once the active driver has released the signal. | I/O | T/S | Programmable Input/Output/Tri-State/Bi-directional Pin. |
| O/D | Open Drain. Allows multiple devices to share this pin as a wired-or. | GLCK/I | IN | Programmable Global Network or Input-only pin. Tie to VCC or GND if unused. |
| | | ACLK/I | IN | Programmable Array Network or Input-only pin. Tie to VCC or GND if unused. |
| | | TDI/RSI* | IN | JTAG Data In/Ram Init. Serial Data In. Tie to VCC if unused. Connect to Serial EPROM data for RAM init. |
| | | TDO/RCO* | OUT | JTAG Data Out/Ram Init Clock. Leave unconnected if unused. Connect to Serial EPROM clock for RAM init. |
| | | TCK | IN | JTAG Clock. Tie to GND if unused. |
| | | TMS | IN | JTAG Test Mode Select. Tie to VCC if unused. |
| | | TRSTB/RRO* | IN | JTAG Reset/RAM Init. Reset Out. Tie to GND if unused. Connect to Serial EPROM reset for RAM init. |
| | | STM | IN | QuickLogic Reserved pin. Tie to GND on the PCB. |

*See QuickNote 65 on the QuickLogic web site for information on RAM initialization.

PQFP 208 PINOUT TABLE

| 208 PQFP | Function | 208 PQFP | Function | 208 PQFP | Function | 208 PQFP | Function | 208 PQFP | Function |
|----------|------------|----------|----------|----------|-----------|----------|----------|----------|----------|
| 1 | I/O | 43 | GND | 85 | TxOut[4] | 127 | GND | 169 | I/O |
| 2 | I/O | 44 | I/O | 86 | TxOut[5] | 128 | I/O | 170 | I/O |
| 3 | I/O | 45 | I/O | 87 | TxOut[6] | 129 | GLCK/1 | 171 | I/O |
| 4 | I/O | 46 | I/O | 88 | TxOut[7] | 130 | ACLK/1 | 172 | I/O |
| 5 | I/O | 47 | I/O | 89 | TxOut[8] | 131 | VCC | 173 | I/O |
| 6 | I/O | 48 | I/O | 90 | TxOut[9] | 132 | ResIn[1] | 174 | I/O |
| 7 | I/O | 49 | I/O | 91 | TxOut[10] | 133 | ResIn[2] | 175 | I/O |
| 8 | I/O | 50 | I/O | 92 | TxOut[11] | 134 | VCC | 176 | I/O |
| 9 | I/O | 51 | I/O | 93 | TxOut[12] | 135 | I/O | 177 | GND |
| 10 | VCC | 52 | I/O | 94 | TxOut[13] | 136 | I/O | 178 | I/O |
| 11 | I/O | 53 | I/O | 95 | GND | 137 | I/O | 179 | I/O |
| 12 | GND | 54 | TDI | 96 | TxOut[14] | 138 | I/O | 180 | I/O |
| 13 | I/O | 55 | RxComDet | 97 | VCC | 139 | I/O | 181 | I/O |
| 14 | I/O | 56 | RxIn[0] | 98 | TxOut[15] | 140 | I/O | 182 | GND |
| 15 | I/O | 57 | RxIn[1] | 99 | TxOut[16] | 141 | I/O | 183 | I/O |
| 16 | I/O | 58 | RxIn[2] | 100 | TxOut[17] | 142 | I/O | 184 | I/O |
| 17 | I/O | 59 | GND | 101 | TxOut[18] | 143 | I/O | 185 | I/O |
| 18 | I/O | 60 | RxIn[3] | 102 | TxOut[19] | 144 | I/O | 186 | I/O |
| 19 | I/O | 61 | VCC | 103 | TRSTB | 145 | VCC | 187 | VCCIO |
| 20 | I/O | 62 | RxIn[4] | 104 | TMS | 146 | I/O | 188 | I/O |
| 21 | I/O | 63 | RxIn[5] | 105 | I/O | 147 | GND | 189 | I/O |
| 22 | I/O | 64 | RxIn[6] | 106 | I/O | 148 | I/O | 190 | I/O |
| 23 | GND | 65 | RxIn[7] | 107 | I/O | 149 | I/O | 191 | I/O |
| 24 | I/O | 66 | RxIn[8] | 108 | I/O | 150 | I/O | 192 | I/O |
| 25 | ResIn[0] | 67 | RxIn[9] | 109 | I/O | 151 | I/O | 193 | I/O |
| 26 | TxCk125_in | 68 | RxIn[10] | 110 | I/O | 152 | I/O | 194 | I/O |
| 27 | VCC | 69 | RxIn[11] | 111 | I/O | 153 | I/O | 195 | I/O |
| 28 | Rst | 70 | RxIn[12] | 112 | I/O | 154 | I/O | 196 | I/O |
| 29 | RxCk125_in | 71 | RxIn[13] | 113 | I/O | 155 | I/O | 197 | I/O |
| 30 | VCC | 72 | RxIn[14] | 114 | VCC | 156 | I/O | 198 | I/O |
| 31 | I/O | 73 | GND | 115 | I/O | 157 | TCK | 199 | GND |
| 32 | I/O | 74 | RxIn[15] | 116 | GND | 158 | STM | 200 | I/O |
| 33 | I/O | 75 | RxIn[16] | 117 | I/O | 159 | I/O | 201 | VCC |
| 34 | I/O | 76 | RxIn[17] | 118 | I/O | 160 | I/O | 202 | I/O |
| 35 | I/O | 77 | RxIn[18] | 119 | I/O | 161 | I/O | 203 | I/O |
| 36 | I/O | 78 | GND | 120 | I/O | 162 | I/O | 204 | I/O |
| 37 | I/O | 79 | RxIn[19] | 121 | I/O | 163 | GND | 205 | I/O |
| 38 | I/O | 80 | TxOut[0] | 122 | I/O | 164 | I/O | 206 | I/O |
| 39 | I/O | 81 | TxOut[1] | 123 | I/O | 165 | VCC | 207 | TDO |
| 40 | I/O | 82 | TxOut[2] | 124 | I/O | 166 | I/O | 208 | I/O |
| 41 | VCC | 83 | VCCIO | 125 | I/O | 167 | I/O | | |
| 42 | I/O | 84 | TxOut[3] | 126 | I/O | 168 | I/O | | |

QL80FC - QuickFC™

PBGA 456 PINOUT TABLE

| 456 | Function | 456 | Function | 456 | Function | 456 | Function | 456 | Function |
|-----|----------|-----|----------|-----|----------|-----|-------------|-----|-----------|
| A1 | I/O | B26 | STM | D25 | I/O | H4 | I/O | M14 | GND/THERM |
| A2 | I/O | C1 | I/O | D26 | I/O | H5 | NC | M15 | GND/THERM |
| A3 | I/O | C2 | I/O | E1 | I/O | H22 | NC | M16 | GND/THERM |
| A4 | I/O | C3 | I/O | E2 | I/O | H23 | I/O | M22 | NC |
| A5 | I/O | C4 | TDO | E3 | I/O | H24 | I/O | M23 | NC |
| A6 | I/O | C5 | I/O | E4 | I/O | H25 | I/O | M24 | I/O |
| A7 | I/O | C6 | I/O | E5 | GND | H26 | I/O | M25 | I/O |
| A8 | I/O | C7 | I/O | E6 | VCC | J1 | I/O | M26 | I/O |
| A9 | I/O | C8 | I/O | E7 | GND | J2 | I/O | N1 | Async_rst |
| A10 | I/O | C9 | I/O | E8 | NC | J3 | I/O | N2 | I/O |
| A11 | I/O | C10 | I/O | E9 | GND | J4 | NC | N3 | I/O |
| A12 | VCCIO | C11 | I/O | E10 | I/O | J5 | GND | N4 | ResIn[0] |
| A13 | I/O | C12 | I/O | E11 | GND | J22 | NC | N5 | VCC |
| A14 | I/O | C13 | I/O | E12 | GND | J23 | NC | N11 | GND/THERM |
| A15 | I/O | C14 | I/O | E13 | VCC | J24 | I/O | N12 | GND/THERM |
| A16 | I/O | C15 | I/O | E14 | GND | J25 | I/O | N13 | GND/THERM |
| A17 | I/O | C16 | I/O | E15 | GND | J26 | I/O | N14 | GND/THERM |
| A18 | I/O | C17 | I/O | E16 | GND | K1 | I/O | N15 | GND/THERM |
| A19 | I/O | C18 | I/O | E17 | NC | K2 | I/O | N16 | GND/THERM |
| A20 | I/O | C19 | I/O | E18 | GND | K3 | I/O | N22 | GND |
| A21 | I/O | C20 | I/O | E19 | NC | K4 | I/O | N23 | I/O |
| A22 | I/O | C21 | I/O | E20 | GND | K5 | VCC | N24 | I/O |
| A23 | I/O | C22 | I/O | E21 | VCC | K22 | GND | N25 | I/O |
| A24 | I/O | C23 | I/O | E22 | GND | K23 | I/O | N26 | I/O |
| A25 | I/O | C24 | I/O | E23 | I/O | K24 | I/O | P1 | I/O |
| A26 | I/O | C25 | TCK | E24 | I/O | K25 | I/O | P2 | I/O |
| B1 | I/O | C26 | I/O | E25 | I/O | K26 | I/O | P3 | I/O |
| B2 | I/O | D1 | I/O | E26 | I/O | L1 | I/O | P4 | I/O |
| B3 | I/O | D2 | I/O | F1 | I/O | L2 | I/O | P5 | NC |
| B4 | I/O | D3 | I/O | F2 | I/O | L3 | I/O | P11 | GND/THERM |
| B5 | I/O | D4 | GND | F3 | I/O | L4 | I/O | P12 | GND/THERM |
| B6 | I/O | D5 | I/O | F4 | NC | L5 | NC | P13 | GND/THERM |
| B7 | I/O | D6 | NC | F5 | VCC | L11 | GND/THERM | P14 | GND/THERM |
| B8 | I/O | D7 | I/O | F22 | VCC | L12 | GND/THERM | P15 | GND/THERM |
| B9 | I/O | D8 | I/O | F23 | NC | L13 | GND/THERM | P16 | GND/THERM |
| B10 | I/O | D9 | GND | F24 | I/O | L14 | GND/THERM | P22 | NC |
| B11 | I/O | D10 | I/O | F25 | I/O | L15 | GND/THERM | P23 | ResIn[1] |
| B12 | I/O | D11 | I/O | F26 | I/O | L16 | GND/THERM | P24 | ResIn[2] |
| B13 | I/O | D12 | GND | G1 | I/O | L22 | NC | P25 | I/O |
| B14 | I/O | D13 | I/O | G2 | I/O | L23 | I/O | P26 | ACLK / 1 |
| B15 | I/O | D14 | I/O | G3 | I/O | L24 | I/O | R1 | I/O |
| B16 | I/O | D15 | GND | G4 | I/O | L25 | I/O | R2 | I/O |
| B17 | I/O | D16 | I/O | G5 | NC | L26 | I/O | R3 | I/O |
| B18 | I/O | D17 | I/O | G22 | GND | M1 | TxClk125_in | R4 | NC |
| B19 | I/O | D18 | GND | G23 | I/O | M2 | RxClk125_in | R5 | NC |
| B20 | I/O | D19 | I/O | G24 | I/O | M3 | I/O | R11 | GND/THERM |
| B21 | I/O | D20 | I/O | G25 | I/O | M4 | NC | R12 | GND/THERM |
| B22 | I/O | D21 | NC | G26 | I/O | M5 | GND | R13 | GND/THERM |
| B23 | I/O | D22 | I/O | H1 | I/O | M11 | GND/THERM | R14 | GND/THERM |
| B24 | I/O | D23 | GND | H2 | I/O | M12 | GND/THERM | R15 | GND/THERM |
| B25 | I/O | D24 | I/O | H3 | I/O | M13 | GND/THERM | R16 | GND/THERM |

QL80FC - QuickFC™

| 456 | Function | 456 | Function | 456 | Function | 456 | Function |
|-----|-------------|------|----------|------|----------|------|-----------|
| R22 | VCC | Y1 | I/O | AC6 | NC | AE5 | RxIn[3] |
| R23 | NC | Y2 | I/O | AC7 | I/O | AE6 | RxIn[4] |
| R24 | I/O | Y3 | I/O | AC8 | I/O | AE7 | RxIn[5] |
| R25 | I/O | Y4 | I/O | AC9 | NC | AE8 | RxIn[6] |
| R26 | GCLK / I | Y5 | I/O | AC10 | I/O | AE9 | RxIn[7] |
| T1 | I/O | Y22 | GND | AC11 | I/O | AE10 | RxIn[8] |
| T2 | I/O | Y23 | I/O | AC12 | NC | AE11 | RxIn[9] |
| T3 | I/O | Y24 | I/O | AC13 | I/O | AE12 | I/O |
| T4 | I/O | Y25 | I/O | AC14 | VCCIO | AE13 | TxOut[0] |
| T5 | VCC | Y26 | I/O | AC15 | NC | AE14 | TxOut[2] |
| T11 | GND/THERMAL | AA1 | I/O | AC16 | I/O | AE15 | TxOut[4] |
| T12 | GND/THERMAL | AA2 | I/O | AC17 | I/O | AE16 | TxOut[6] |
| T13 | GND/THERMAL | AA3 | NC | AC18 | NC | AE17 | TxOut[8] |
| T14 | GND/THERMAL | AA4 | NC | AC19 | I/O | AE18 | TxOut[10] |
| T15 | GND/THERMAL | AA5 | VCC | AC20 | I/O | AE19 | TxOut[12] |
| T16 | GND/THERMAL | AA22 | VCC | AC21 | I/O | AE20 | TxOut[14] |
| T22 | GND | AA23 | NC | AC22 | NC | AE21 | TxOut[16] |
| T23 | I/O | AA24 | I/O | AC23 | GND | AE22 | TxOut[18] |
| T24 | I/O | AA25 | I/O | AC24 | I/O | AE23 | NC |
| T25 | I/O | AA26 | I/O | AC25 | I/O | AE24 | TMS |
| T26 | I/O | AB1 | I/O | AC26 | I/O | AE25 | I/O |
| U1 | I/O | AB2 | I/O | AD1 | I/O | AE26 | I/O |
| U2 | I/O | AB3 | I/O | AD2 | NC | AF1 | I/O |
| U3 | I/O | AB4 | I/O | AD3 | I/O | AF2 | I/O |
| U4 | I/O | AB5 | GND | AD4 | I/O | AF3 | RxIn[10] |
| U5 | GND | AB6 | VCC | AD5 | I/O | AF4 | RxIn[11] |
| U22 | NC | AB7 | NC | AD6 | I/O | AF5 | RxIn[12] |
| U23 | I/O | AB8 | NC | AD7 | I/O | AF6 | RxIn[13] |
| U24 | I/O | AB9 | NC | AD8 | I/O | AF7 | RxIn[14] |
| U25 | I/O | AB10 | VCC | AD9 | I/O | AF8 | RxIn[15] |
| U26 | I/O | AB11 | GND | AD10 | I/O | AF9 | RxIn[16] |
| V1 | I/O | AB12 | NC | AD11 | I/O | AF10 | RxIn[17] |
| V2 | I/O | AB13 | I/O | AD12 | RxComDet | AF11 | RxIn[18] |
| V3 | I/O | AB14 | GND | AD13 | I/O | AF12 | RxIn[19] |
| V4 | NC | AB15 | VCC | AD14 | I/O | AF13 | TxOut[1] |
| V5 | NC | AB16 | I/O | AD15 | I/O | AF14 | TxOut[3] |
| V22 | GND | AB17 | NC | AD16 | I/O | AF15 | TxOut[5] |
| V23 | NC | AB18 | VCC | AD17 | I/O | AF16 | TxOut[7] |
| V24 | I/O | AB19 | GND | AD18 | I/O | AF17 | TxOut[9] |
| V25 | I/O | AB20 | NC | AD19 | I/O | AF18 | TxOut[11] |
| V26 | I/O | AB21 | VCC | AD20 | I/O | AF19 | TxOut[13] |
| W1 | I/O | AB22 | GND | AD21 | I/O | AF20 | TxOut[15] |
| W2 | I/O | AB23 | I/O | AD22 | I/O | AF21 | TxOut[17] |
| W3 | I/O | AB24 | I/O | AD23 | TRSTB | AF22 | TxOut[19] |
| W4 | I/O | AB25 | I/O | AD24 | I/O | AF23 | I/O |
| W5 | NC | AB26 | I/O | AD25 | I/O | AF24 | I/O |
| W22 | NC | AC1 | I/O | AD26 | I/O | AF25 | I/O |
| W23 | I/O | AC2 | I/O | AE1 | TDI | AF26 | I/O |
| W24 | I/O | AC3 | NC | AE2 | RxIn[0] | | |
| W25 | I/O | AC4 | GND | AE3 | RxIn[1] | | |
| W26 | I/O | AC5 | I/O | AE4 | RxIn[2] | | |

TIMING DIAGRAMS

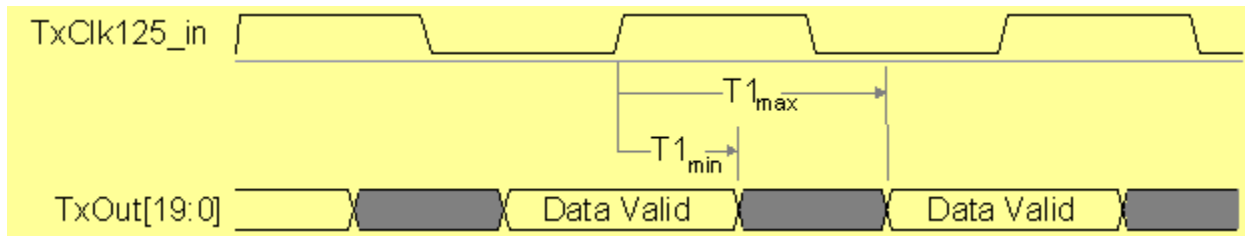

FIGURE 7. Transmit Timing Diagram

Transmit Timing Characteristics

| Parameter | Description | Min | Typ | Max | Units |
|-----------|---------------------|------------|------------|------------|-----------|
| T1 | Clock to Out | 2.5 | 3.7 | 5.6 | ns |

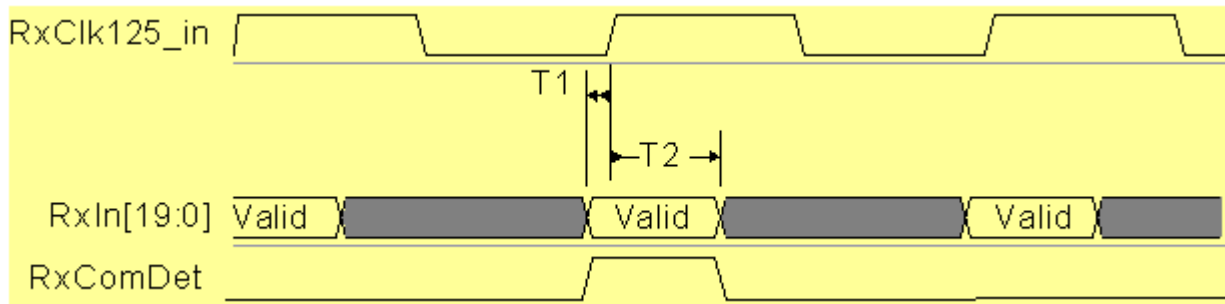

FIGURE 8. Receive Timing Diagram

Receive Timing Characteristics

| Parameter | Description | Min | Typ | Max | Units |
|-----------|-------------------|------------|------------|-----|-----------|
| T1 | Setup time | 0.0 | | | ns |
| T2 | Hold time | 2.3 | 1.5 | | ns |

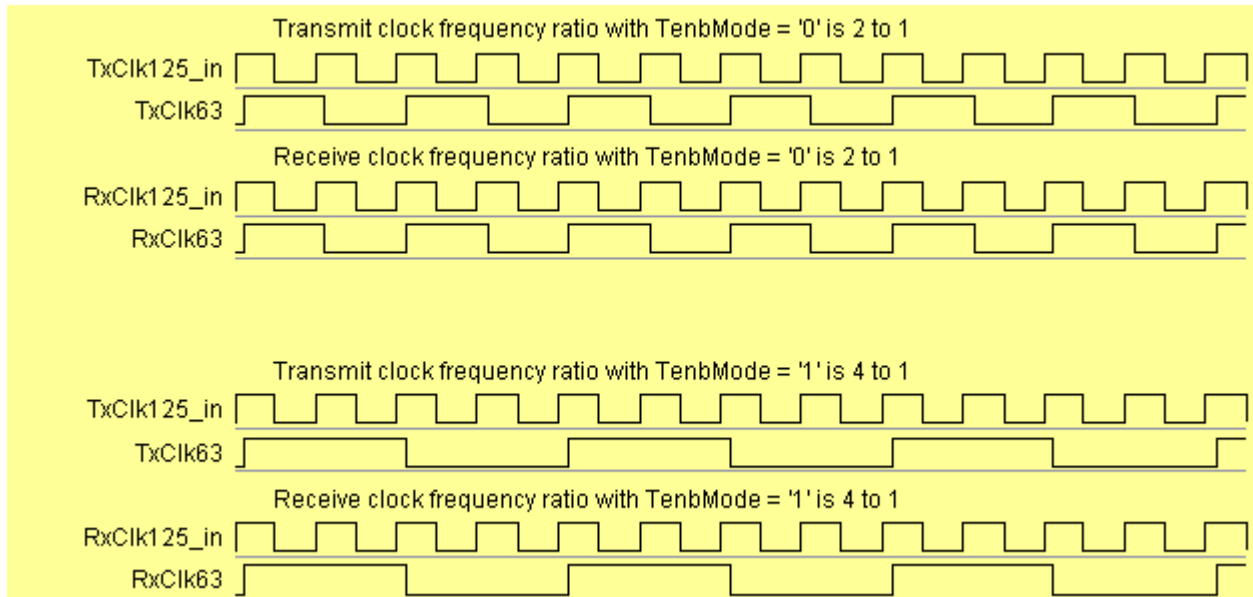

FIGURE 9. Clock Frequency Ratios are Dependent on tenbMode setting

REFERENCE DEVELOPMENT KIT

QuickLogic has designed an evaluation board, which will allow the system designer to test their designs in hardware. The board plugs into a PCI expansion slot in a Windows PC and allows the user to communicate with the QuickLogic ENDEC chip via a user modifiable software script and the PCI bus. The block diagram for the board is shown below. PCI speeds of up to 64 bits at 75 MHz are supported via QuickLogic's QL5064 device, enabling system read/write speeds matching those of the Fibre Channel link. There is a socket for the ENDEC chip, and connection points for a logic analyzer on the board. There is

also a GBIC Fibre Channel connector on the board to allow communication with other Fibre Channel devices.

A Reference Design is supplied by QuickLogic to load into the programmable portion of the ENDEC chip. The Reference Design code will allow the system designer to immediately have an operational chip for use on the reference board. The source code for the reference design and software is available to the system designer for use or modification as he or she wishes, free of charge.

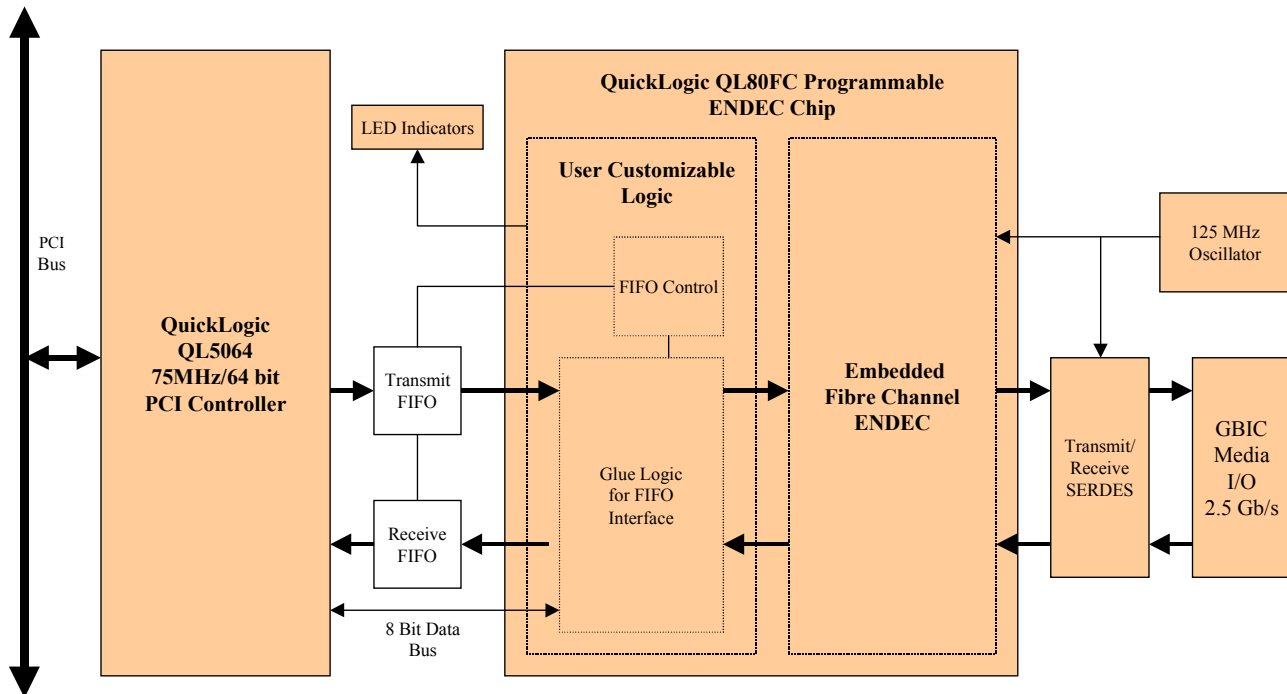

FIGURE 10. Reference Board Block Diagram

QL80FC - QuickFC™

Absolute Maximum Ratings

| | | | |
|-----------------------------|----------------------|-------------------------------|------------------|
| VCC Voltage | -0.5 to 4.6V | DC Input Current | ±20 mA |
| VCCIO Voltage | -0.5 to 7.0V | ESD Pad Protection | ±2000V |
| Input Voltage | -0.5V to VCCIO +0.5V | Storage Temperature | -65°C to + 150°C |
| Latch-up Immunity | ±200mA | Lead Temperature | 300°C |

Operating Range

| Symbol | Parameter | Industrial | | Commercial | | Unit |
|--------|-----------------------------|------------|------|------------|------|------|
| | | Min | Max | Min | Max | |
| VCC | Supply Voltage | 3.0 | 3.6 | 3.0 | 3.6 | V |
| VCCIO | I/O Input Tolerance Voltage | 3.0 | 5.5 | 3.0 | 5.25 | V |
| TA | Ambient Temperature | -40 | 85 | 0 | 70 | °C |
| K | Delay Factor -A Speed Grade | 0.43 | 0.90 | 0.46 | 0.88 | |

DC Characteristics

| Symbol | Parameter | Conditions | Min | Max | Unit |
|--------|----------------------------------|------------------------|------------|-----------|------|
| VIH | Input HIGH Voltage | | 0.5VCC | VCCIO+0.5 | V |
| VIL | Input LOW Voltage | | -0.5 | 0.3VCC | V |
| VOH | Output HIGH Voltage | IOH = -12 mA | 2.4 | | V |
| | | IOH = -500 µA | 0.9VCC | | V |
| VOL | Output LOW Voltage | IOL = 16 mA | | 0.45 | V |
| | | IOL = 1.5 mA | | 0.1VCC | V |
| II | I or I/O Input Leakage Current | VI = VCCIO or GND | -10 | 10 | µA |
| IOZ | 3-State Output Leakage Current | VI = VCCIO or GND | -10 | 10 | µA |
| CI | Input Capacitance [1] | | | 10 | pF |
| IOS | Output Short Circuit Current [2] | VO = GND | -15 | -180 | mA |
| | | VO = VCC | 40 | 210 | mA |
| ICC | D.C. Supply Current [3] | VI, VIO = VCCIO or GND | 0.50 (typ) | 2 | mA |
| ICCIO | D.C. Supply Current on VCCIO | | 0 | 100 | µA |

Notes:

- [1] Capacitance is sample tested only.
- [2] Only one output at a time. Duration should not exceed 30 seconds.
- [3] See Application Note 32: Power calculations for QuickLogic devices.

AC CHARACTERISTICS at VCC = 3.3V, TA = 25°C (K = 1.00)

(To calculate delays, multiply the appropriate K factor in the “Operating Range” section by the following numbers.)

Logic Cells

| Symbol | Parameter | Propagation Delays (ns) | | | | |
|--------|-------------------------|-------------------------|-----|-----|-----|-----|
| | | Fanout [5] | | | | |
| | | 1 | 2 | 3 | 4 | 8 |
| tPD | Combinatorial Delay [6] | 1.4 | 1.7 | 1.9 | 2.2 | 3.2 |
| tSU | Setup Time [6] | 1.7 | 1.7 | 1.7 | 1.7 | 1.7 |
| tH | Hold Time | 0.0 | 0.0 | 0.0 | 0.0 | 0.0 |
| tCLK | Clock to Q Delay | 0.7 | 1.0 | 1.2 | 1.5 | 2.5 |
| tCWHI | Clock High Time | 1.2 | 1.2 | 1.2 | 1.2 | 1.2 |
| tCWLO | Clock Low Time | 1.2 | 1.2 | 1.2 | 1.2 | 1.2 |
| tSET | Set Delay | 1.0 | 1.3 | 1.5 | 1.8 | 2.8 |
| tRESET | Reset Delay | 0.8 | 1.1 | 1.3 | 1.6 | 2.6 |
| tSW | Set Width | 1.9 | 1.9 | 1.9 | 1.9 | 1.9 |
| tRW | Reset Width | 1.8 | 1.8 | 1.8 | 1.8 | 1.8 |

RAM Cell Synchronous Write Timing

| Symbol | Parameter | Propagation Delays (ns) | | | | |
|--------|------------------------|-------------------------|-----|-----|-----|-----|
| | | Fanout [4] | | | | |
| | | 1 | 2 | 3 | 4 | 8 |
| TSWA | WA Setup Time to WCLK | 1.0 | 1.0 | 1.0 | 1.0 | 1.0 |
| THWA | WA Hold Time to WCLK | 0.0 | 0.0 | 0.0 | 0.0 | 0.0 |
| TSWD | WD Setup Time to WCLK | 1.0 | 1.0 | 1.0 | 1.0 | 1.0 |
| THWD | WD Hold Time to WCLK | 0.0 | 0.0 | 0.0 | 0.0 | 0.0 |
| TSWE | WE Setup Time to WCLK | 1.0 | 1.0 | 1.0 | 1.0 | 1.0 |
| THWE | WE Hold Time to WCLK | 0.0 | 0.0 | 0.0 | 0.0 | 0.0 |
| TWCRD | WCLK to RD (WA=RA) [4] | 5.0 | 5.3 | 5.6 | 5.9 | 7.1 |

Notes:

- [4] Stated timing for worst case Propagation Delay over process variation at VCC=3.3V and TA=25°C. Multiply by the appropriate Delay Factor, K, for speed grade, voltage and temperature settings as specified in the Operating Range.
- [5] These limits are derived from a representative selection of the slowest paths through the QuickRAM logic cell including typical net delays. Worst case delay values for specific paths should be determined from timing analysis of your particular design.

RAM Cell Synchronous Read Timing

| Symbol | Parameter | Propagation Delays (ns) Fanout | | | | |
|--------|-----------------------|-----------------------------------|-----|-----|-----|-----|
| | | 1 | 2 | 3 | 4 | 8 |
| TSRA | RA Setup Time to RCLK | 1.0 | 1.0 | 1.0 | 1.0 | 1.0 |
| THRA | RA Hold Time to RCLK | 0.0 | 0.0 | 0.0 | 0.0 | 0.0 |
| TSRE | RE Setup Time to RCLK | 1.0 | 1.0 | 1.0 | 1.0 | 1.0 |
| THRE | RE Hold Time to RCLK | 0.0 | 0.0 | 0.0 | 0.0 | 0.0 |
| TRCRD | RCLK to RD [5] | 4.0 | 4.3 | 4.6 | 4.9 | 6.1 |

RAM Cell Asynchronous Read Timing

| Symbol | Parameter | Propagation Delays (ns) Fanout | | | | |
|--------|--------------|-----------------------------------|-----|-----|-----|-----|
| | | 1 | 2 | 3 | 4 | 8 |
| RPDRD | RA to RD [5] | 3.0 | 3.3 | 3.6 | 3.9 | 5.1 |

Input-Only Cells

| Symbol | Parameter | Propagation Delays (ns) Fanout [5] | | | | | | |
|--------|--|---------------------------------------|-----|-----|-----|-----|-----|-----|
| | | 1 | 2 | 3 | 4 | 8 | 12 | 24 |
| TIN | High Drive Input Delay | 1.5 | 1.6 | 1.8 | 1.9 | 2.4 | 2.9 | 4.4 |
| TINI | High Drive Input, Inverting Delay | 1.6 | 1.7 | 1.9 | 2.0 | 2.5 | 3.0 | 4.5 |
| TISU | Input Register Set-Up Time | 3.1 | 3.1 | 3.1 | 3.1 | 3.1 | 3.1 | 3.1 |
| TIH | Input Register Hold Time | 0.0 | 0.0 | 0.0 | 0.0 | 0.0 | 0.0 | 0.0 |
| TICLK | Input Register Clock To Q | 0.7 | 0.8 | 1.0 | 1.1 | 1.6 | 2.1 | 3.6 |
| TIRST | Input Register Reset Delay | 0.6 | 0.7 | 0.9 | 1.0 | 1.5 | 2.0 | 3.5 |
| TIESU | Input Register Clock Enable Setup Time | 2.3 | 2.3 | 2.3 | 2.3 | 2.3 | 2.3 | 2.3 |
| TIEH | Input Register Clock Enable Hold Time | 0.0 | 0.0 | 0.0 | 0.0 | 0.0 | 0.0 | 0.0 |

Clock Cells

| Symbols | Parameter | Propagation Delays (ns) Loads per Half Column [6] | | | | | | | |
|---------|---------------------------|--|-----|-----|-----|-----|-----|-----|-----|
| | | 1 | 2 | 3 | 4 | 8 | 10 | 12 | 15 |
| tACK | Array Clock Delay | 1.2 | 1.2 | 1.3 | 1.3 | 1.5 | 1.6 | 1.7 | 1.8 |
| tGCKP | Global Clock Pin Delay | 0.7 | 0.7 | 0.7 | 0.7 | 0.7 | 0.7 | 0.7 | 0.7 |
| tGCKB | Global Clock Buffer Delay | 0.8 | 0.8 | 0.9 | 0.9 | 1.1 | 1.2 | 1.3 | 1.4 |

Notes:

- [6] The array distributed networks consist of 40 half columns and the global distributed networks consist of 44 half columns, each driven by an independent buffer. The number of half columns used does not affect clock buffer delay. The array clock has up to 8 loads per half column. The global clock has up to 11 loads per half column.

I/O Cell Input Delays

| Symbol | Parameter | Propagation Delays (ns) Fanout [5] | | | | | |
|--------|---|---------------------------------------|-----|-----|-----|-----|-----|
| | | 1 | 2 | 3 | 4 | 8 | 10 |
| tI/O | Input Delay (bidirectional pad) | 1.3 | 1.6 | 1.8 | 2.1 | 3.1 | 3.6 |
| TISU | Input Register Set-Up Time | 3.1 | 3.1 | 3.1 | 3.1 | 3.1 | 3.1 |
| TIH | Input Register Hold Time | 0.0 | 0.0 | 0.0 | 0.0 | 0.0 | 0.0 |
| TIOCLK | Input Register Clock To Q | 0.7 | 1.0 | 1.2 | 1.5 | 2.5 | 3.0 |
| TIORST | Input Register Reset Delay | 0.6 | 0.9 | 1.1 | 1.4 | 2.4 | 2.9 |
| TIESU | Input Register clock Enable Set-Up Time | 2.3 | 2.3 | 2.3 | 2.3 | 2.3 | 2.3 |
| TIEH | Input Register Clock Enable Hold Time | 0.0 | 0.0 | 0.0 | 0.0 | 0.0 | 0.0 |

I/O Cell Output Delays

| Symbol | Parameter | Propagation Delays (ns) Output Load Capacitance (pF) | | | | |
|--------|------------------------------------|---|-----|-----|-----|-----|
| | | 30 | 50 | 75 | 100 | 150 |
| TOUTLH | Output Delay Low to High | 2.1 | 2.5 | 3.1 | 3.6 | 4.7 |
| TOUTH | Output Delay High to Low | 2.2 | 2.6 | 3.2 | 3.7 | 4.8 |
| TPZH | Output Delay Tri-state to High | 1.2 | 1.7 | 2.2 | 2.8 | 3.9 |
| TPZL | Output Delay Tri-state to Low | 1.6 | 2.0 | 2.6 | 3.1 | 4.2 |
| TPHZ | Output Delay High to Tri-State [8] | 2.0 | | | | |
| TPLZ | Output Delay Low to Tri-State [8] | 1.2 | | | | |

Notes:

[7] The following loads are used for tPXZ:

