

# MCO-3S

SMD Clock Oscillator  
CMOS

QuartzCom  
the communications company

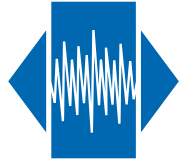

## Features

- Applications: telecommunications, wireless communications
- Miniature package: 5.0 x 3.2 x 1.3 mm
- Frequency up to 125 MHz
- High shock and vibration resistant

Parameter	Specification			
	MCO-3S18	MCO-3S25	MCO-3S3	MCO-3S5
Frequency range	12 kHz ~ 125 MHz			0.012 ~ 75 MHz
Standard frequencies	11.0592, 20.00, 25.00, 40.00, 44.00, 106.25, 125 MHz			on request
Supply voltage	+1.8 V $\pm$ 5 %	+2.5 V $\pm$ 5 %	+3.3 V $\pm$ 10 %	+5.0 V $\pm$ 10 %
Supply current	0.03 ~ 50 MHz	< 12 mA	< 12 mA	< 15 mA
	51 ~ 70 MHz	< 12 mA	< 15 mA	< 20 mA
	71 ~ 125 MHz	< 20 mA	< 25 mA	< 30 mA
Frequency stability (*)	$\pm$ 25 ~ $\pm$ 50 ppm			
Output signal	CMOS			
Output level	$V_{OH} \geq 0.9 V_{dc}$		$V_{OL} \leq 0.1 V_{dc}$	
Output load	15 pF ~ 25 pF		15 pF ~ 25 pF (50 pF on request)	
Jitter (rms)	< 1 ps @ 12 kHz ~ 20 MHz from carrier frequency			
Symmetry	45 ~ 55 %		@ 1/2 Vdc	
Rise / fall time	3 ~ 8 ns			
Tri-state function	pin #1 = high or open pin #1 = low		pin #3 $\rightarrow$ signal pin #3 $\rightarrow$ high impedance	
Operating temperature range	-20 ~ +70 °C -40 ~ +85 °C		standard application industrial application	
Storage temperature range	-55 ~ +125 °C			
Packaging units	tape & reel		1'000 or 2'500 pieces	
(*) All inclusive: frequency stability vs. temperature, tolerance, aging, supply & load variation				
Customer specifications on request				

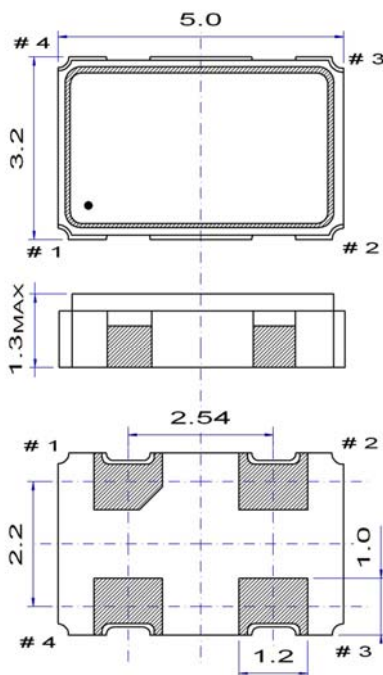

## Pin function

- # 1 Tri-state
- # 2 GND
- # 3 Output
- # 4 Vdc

## Example for solder pattern

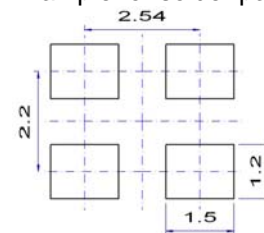

Do not design any conductive path between the pattern

## Example for IR reflow soldering temperature

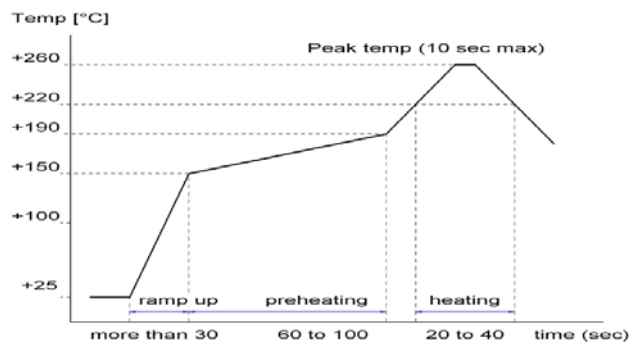

2002/95/EC RoHS compliant

31 Mar. 10

