

---

# HN62V454B Series

262144-word × 16-bit CMOS Mask Programmable ROM

# HITACHI

ADE-203-681 (Z)  
Preliminary  
Rev. 0.0  
Nov. 20, 1996

---

## Description

The HN62V454B is a 262144 word by 16 bit CMOS mask programmable ROM. Its low operating voltage of 2.7 V (min) is suitable for most handy terminal systems.

## Features

- Low voltage operation: 2.7 V to 3.6 V
- High speed—access time: 200 ns (max)
- Low power
  - Active: 72 mW (max)
  - Standby: 72  $\mu$ W (max)
- Directly LVTTL compatible
- All inputs and outputs

## Ordering Information

Type No.	Access time	Package
HN62V454BP-20	200 ns	600 mil 40-pin plastic DIP (DP-40)
HN62V454BCP-20	200 ns	44-pin plastic PLCC (CP-44)

## HN62V454B Series

### Pin Arrangement

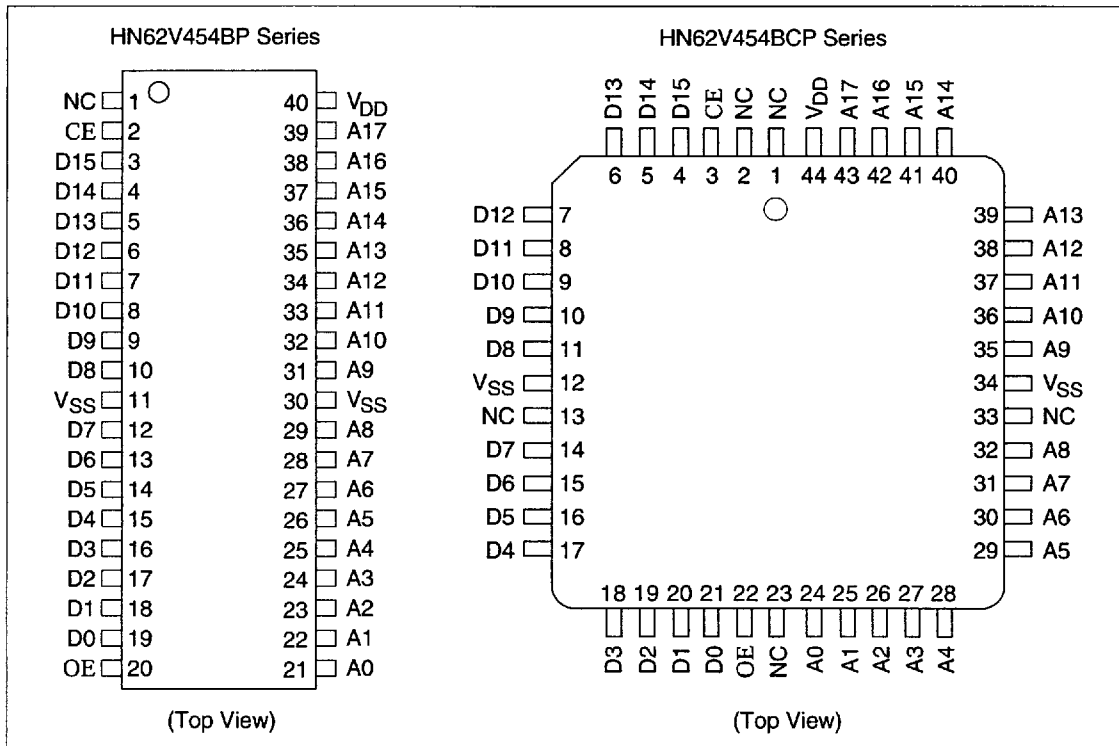

### Pin Description

Pin Name	Function
A0 to A17	Address inputs
D0 to D15	Data outputs
CE	Chip enable
OE	Output enable
NC	No connection
V <sub>DD</sub>	Power supply
V <sub>SS</sub>	Ground

**Block Diagram**

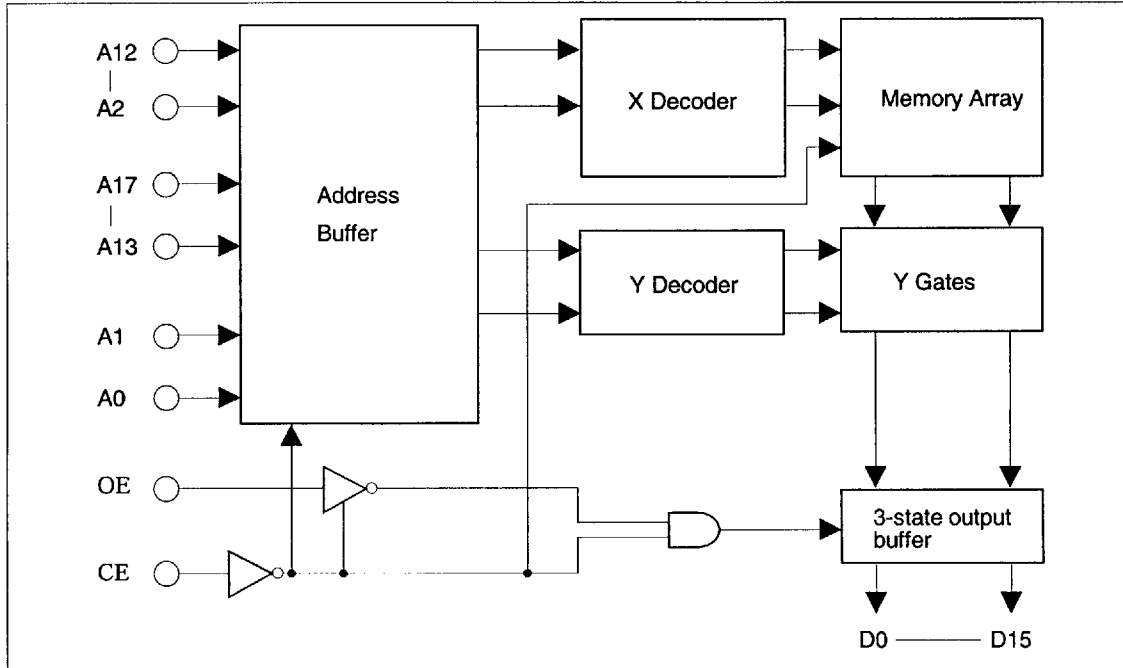

**Mode Selection**

Mode	Pin			Address Input	
	CE	OE	Data output	LSB	MSB
Standby	H	x* <sup>1</sup>	High-Z* <sup>2</sup>	—	—
Output disable	L	H	High-Z* <sup>2</sup>	—	—
Read	L	L	Dout	A0	A17

Notes: 1. x: Don't care.  
2. High-Z: High impedance

## HN62V454B Series

### Absolute Maximum Ratings

Parameter	Symbol	Value	Unit
Supply voltage*	$V_{DD}$	-0.3 to + 5.5	V
All input and output voltage*	$V_{in}, V_{out}$	-0.3 to $V_{DD} + 0.3$	V
Operating temperature range	$T_{opr}$	0 to + 70	°C
Storage temperature range	$T_{stg}$	-55 to + 125	°C
Temperature under bias	$T_{bias}$	-20 to + 85	°C

Note: With respect to  $V_{SS}$ .

### Recommended DC Operating Conditions ( $T_a = 0$ to + 70°C)

Parameter	Symbol	Min	Typ	Max	Unit
Supply voltage	$V_{DD}$	2.7	3.0	3.6	V
Supply voltage	$V_{SS}$	0	0	0	V
Input voltage	$V_{IH}$	2.2	—	$V_{DD} + 0.3$	V
Input voltage	$V_{IL}$	-0.3	—	0.8	V

### DC Characteristics ( $V_{DD} = 2.7$ V to 3.6 V, $V_{SS} = 0$ V, $T_a = 0$ to + 70°C)

Parameter	Symbol	Min	Max	Unit	Test conditions
Supply current Active	$I_{DD}$	—	20	mA	$V_{DD} = 3.6$ V, $I_{DOUT} = 0$ mA, $t_{RC} = 200$ ns
Supply current Standby	$I_{SB1}$	—	20	μA	$V_{DD} = 3.6$ V, $CE \geq V_{DD} - 0.2$ V
Supply current Standby	$I_{SB2}$	—	3	mA	$V_{DD} = 3.6$ V, $CE \geq 2.2$ V
Input leakage current	$ I_{IL} $	—	2	μA	$V_{in} = 0$ to $V_{DD}$
Output leakage current	$ I_{OL} $	—	2	μA	$CE = 2.2$ V, $V_{out} = 0$ to $V_{DD}$
Output voltage	$V_{OH}$	$V_{DD} - 0.2$	—	V	$I_{OH} = -100$ μA
Output voltage	$V_{OL}$	—	0.2	V	$I_{OL} = 100$ μA

### Capacitance ( $V_{DD} = 2.7$ V to 3.6 V, $V_{SS} = 0$ V, $T_a = 25$ °C, $V_{in} = 0$ V, $f = 1$ MHz)

Parameter	Symbol	Min	Max	Unit
Input capacitance*	$C_{in}$	—	10	pF
Output capacitance*	$C_{out}$	—	15	pF

Note: This parameter is sampled and not 100% tested.

---

**HN62V454B Series**

---

**AC Characteristics** ( $V_{DD} = 2.7\text{ V to }3.6\text{ V}$ ,  $V_{SS} = 0\text{ V}$ ,  $T_a = 0\text{ to }+70^\circ\text{C}$ )

- Output load:  $C_L = 50\text{ pF}$  (including jig)
- Input pulse level: 0.4 to 2.4 V
- Input and output timing reference levels: 1.4 V
- Input rise and fall time: 5 ns

Parameter	Symbol	HN62V454B-20		Unit	Note
		Min	Max		
Read cycle time	$t_{RC}$	200	—	ns	
Address access	$t_{AA}$	—	200	ns	
CE access time	$t_{ACE}$	—	200	ns	
OE access time	$t_{OE}$	—	70	ns	
Output hold time from address change	$t_{DHA}$	0	—	ns	
Output hold time from CE	$t_{DHC}$	0	—	ns	
Output hold time from OE	$t_{DHO}$	0	—	ns	
CE to output in high-Z	$t_{CHZ}$	—	70	ns	1
OE to output in high-Z	$t_{OHZ}$	—	70	ns	1
CE to output in low-Z	$t_{CLZ}$	5	—	ns	
OE to output in low-Z	$t_{OLZ}$	5	—	ns	

Note: 1.  $t_{CHZ}$  and  $t_{OHZ}$  are defined as the time at which the output achieves the open circuit conditions and are not referred to output voltage levels.

## HN62V454B Series

### Timing Waveform

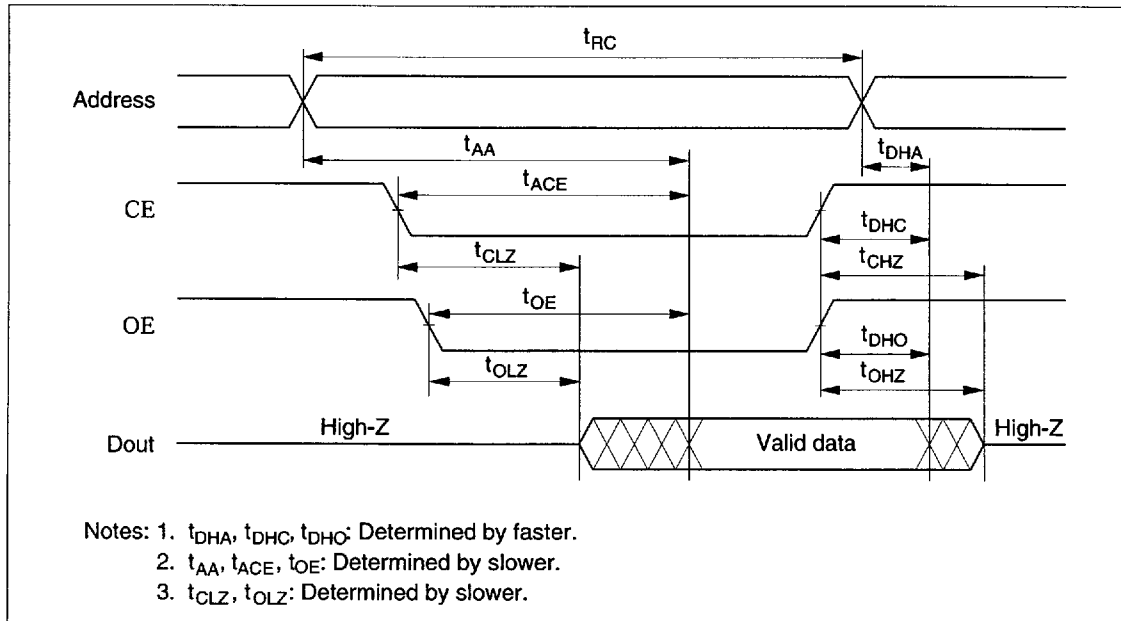

**HN62V454B Series**

**Package Dimensions**

Unit: mm

**HN62V454BP Series (DP-40)**

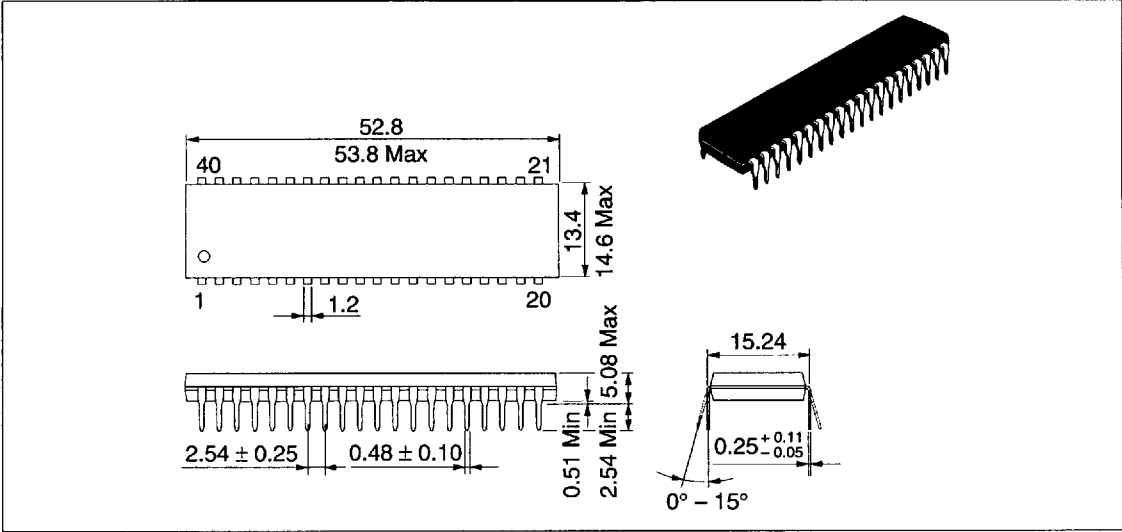

**HN62V454BCP Series (CP-44)**

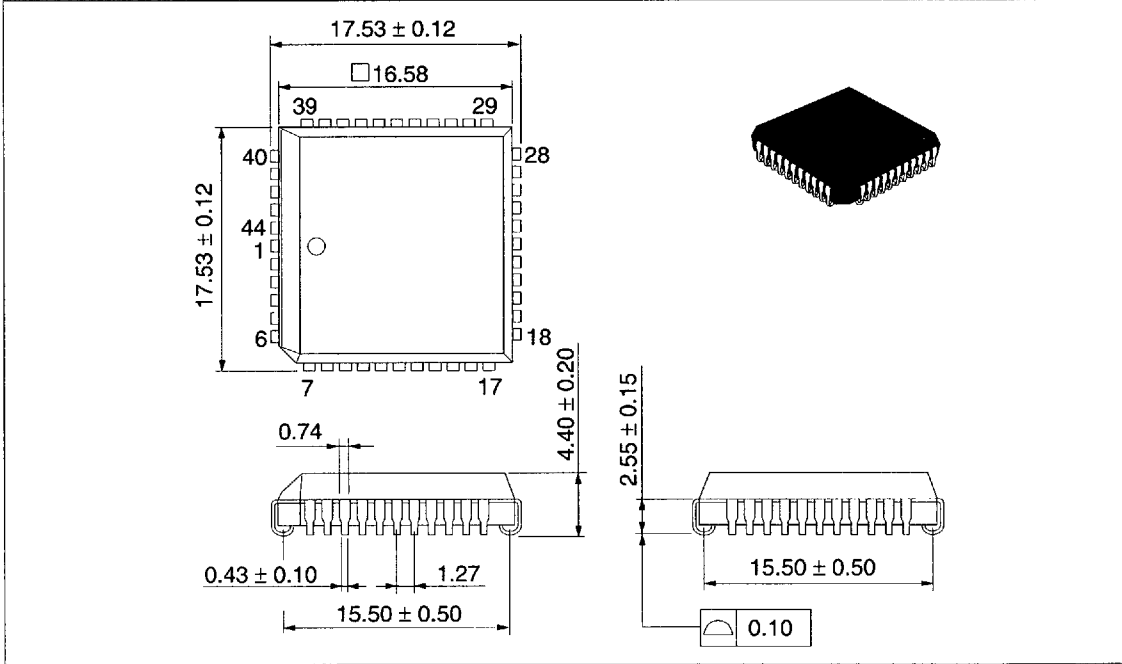

---

## HN62V454B Series

---

### Revision Record

Rev.	Date	Contents of Modification	Drawn by	Approved by
0.0	Nov. 20, 1996	Initial issue		

---

When using this document, keep the following in mind:

1. This document may, wholly or partially, be subject to change without notice.
2. All rights are reserved: No one is permitted to reproduce or duplicate, in any form, the whole or part of this document without Hitachi's permission.
3. Hitachi will not be held responsible for any damage to the user that may result from accidents or any other reasons during operation of the user's unit according to this document.
4. Circuitry and other examples described herein are meant merely to indicate the characteristics and performance of Hitachi's semiconductor products. Hitachi assumes no responsibility for any intellectual property claims or other problems that may result from applications based on the examples described herein.
5. No license is granted by implication or otherwise under any patents or other rights of any third party or Hitachi, Ltd.
6. **MEDICAL APPLICATIONS:** Hitachi's products are not authorized for use in **MEDICAL APPLICATIONS** without the written consent of the appropriate officer of Hitachi's sales company. Such use includes, but is not limited to, use in life support systems. Buyers of Hitachi's products are requested to notify the relevant Hitachi sales offices when planning to use the products in **MEDICAL APPLICATIONS**.