

Integrated Current-mode Buck-Boost DC/DC Controller

Automotive White LED Driver IC



BD8112EFV-M

●Description

BD8112EFV-M is a white LED driver with the capability of withstanding high input voltage (36V MAX). This driver has 2ch constant-current drivers integrated in 1-chip, which each channel can draw up to 150mA max, so that high brightness LED driving can be realized. Furthermore, a current-mode buck-boost DC/DC controller is also integrated to achieve stable operation against voltage input and also to remove the constraint of the number of LEDs in series connection. The brightness can be controlled by either PWM or VDAC techniques.

●Features

- 1) Input voltage range 5.0 – 30 V
- 2) Integrated buck-boost current-mode DC/DC controller
- 3) Two integrated LED current driver channels (150 mA max. each channel)
- 4) PWM Light Modulation (Minimum Pulse Width 25 μs)
- 5) Oscillation frequency accuracy ±5%
- 6) Built-in protection functions (UVLO, OVP, TSD, OCP, SCP)
- 7) LED abnormal status detection function (OPEN/ SHORT)
- 8) HTSSOP-B24 package

●Applications

Backlight for display audio, small type panels, etc.

●Absolute maximum ratings (Ta=25°C)

Parameter	Symbol	Rating	Unit
Power supply voltage	VCC	36	V
BOOT Voltage	VBOOT	41	V
SW,CS,OUTH Voltage	VSW, VCS, VOUTH	36	V
BOOT-SW Voltage	VBOOT-SW	7	V
LED output voltage	VLED1,2	36	V
VREG, OVP, OUTL, FAIL1, FAIL2, LEDEN, ISET, VDAC, PWM, SS, COMP, RT, SYNC, EN voltage	VVREG, VOVP, VOUTL, VFAIL1, VFAIL2, VLEDEN, VISET, VVDAC, VPWM, VSS, VCOMP, VRT, VSYNC, VEN	-0.3~7 < VCC	V
Power Consumption	Pd	1.10 ^{*1}	W
Operating temperature range	Topr	-40~+105	°C
Storage temperature range	Tstg	-55~+150	°C
LED maximum output current	ILED	150 ^{*2} ^{*3}	mA
Junction temperature	Tjmax	150	°C

*1 IC mounted on glass epoxy board measuring 70mm×70mm×1.6mm, power dissipated at a rate of 8.8mw/°C at temperatures above 25°C.

*2 Dispersion figures for LED maximum output current and V_F are correlated. Please refer to data on separate sheet.

*3 Amount of current per channel.

●Operating conditions (Ta=25°C)

Parameter	Symbol	Target value	Unit
Power supply voltage	VCC	5.0~30	V
Oscillating frequency range	FOSC	250~600	kHz
External synchronization frequency range ^{*4} ^{*5}	FSYNC	fosc~600	kHz
External synchronization pulse duty range	FSDUTY	40~60	%

*4 Connect SYNC to GND or OPEN when not using external frequency synchronization.

*5 Do not switch between internal and external synchronization when an external synchronization signal is input to the device.

●Electrical characteristics (unless otherwise specified, VCC=12V Ta=25°C)

Parameter	Symbol	Target value			Unit	Conditions
		Min	Typ	Max.		
Circuit current	ICC	-	7	14	mA	EN=Hi, SYNC=Hi, RT=OPEN PWM=Low, ISET=OPEN, CIN=10 μ F
Standby current	IST	-	4	8	μ A	EN=Low
[VREG Block (VREG)]						
Reference voltage	VREG	4.5	5	5.5	V	IREG=-5mA, CREG=2.2 μ F
[OUTH Block]						
OUTH high-side ON resistance	RONHH	1.5	3.5	7.0	Ω	ION=-10mA
OUTH low-side ON resistance	RONHL	1.0	2.5	5.0	Ω	ION=10mA
Over-current protection operating voltage	VOLIMIT	VCC -0.66	VCC -0.6	VCC -0.54	V	
[OUTL Block]						
OUTL high-side ON resistance	RONLH	2.0	4.0	8.0	Ω	ION=-10mA
OUTL low-side ON resistance	RONLL	1.0	2.5	5.0	Ω	ION=10mA
[SW Block]						
SW low-side ON resistance	RON_SW	2.0	4.5	9.0	Ω	ION_SW=10mA
[Error Amplifier Block]						
LED voltage	VLED	0.9	1.0	1.1	V	
COMP sink current	ICOMPSINK	15	25	35	μ A	VLED=2V, Vcomp=1V
COMP source current	ICOMPSOURCE	-35	-25	-15	μ A	VLED=0V, Vcomp=1V
[Oscillator Block]						
Oscillating frequency	FOSC	285	300	315	KHz	RT=100k Ω
[OVP Block]						
Over-voltage detection reference voltage	VOVP	1.9	2.0	2.1	V	VOVP=Sweep up
OVP hysteresis width	VOHYS	0.45	0.55	0.65	V	VOVP=Sweep down
SCP Latch OFF Delay Time	TSCP	70	100	130	ms	RT=100k Ω
[UVLO Block]						
UVLO voltage	VUVLO	4.0	4.3	4.6	V	VCC : Sweep down
UVLO hysteresis width	VUHYS	50	150	250	mV	VCC : Sweep up
[LED Output Block]						
LED current relative dispersion width	Δ ILED1	-3	-	+3	%	ILED=50mA, Δ ILED1=(ILED/ILED_AVG-1) \times 100
LED current absolute dispersion width	Δ ILED2	-5	-	+5	%	ILED=50mA, Δ ILED2=(ILED/50mA-1) \times 100
ISET voltage	VISET	1.96	2.0	2.04	V	RISET=120k Ω
PWM minimum pulse width	Tmin	25	-	-	μ s	FPWM=150Hz, ILED=50mA
PWM maximum duty	Dmax	-	-	100	%	FPWM=150Hz, ILED=50mA
PWM frequency	FPWM	-	-	20	KHz	Duty=50%, ILED=50mA
VDAC gain	GVDAC	-	25	-	mA/V	VDAC=0~2V, RISET=120k Ω ILED=VDAC \div RISET \times Gain
Open detection voltage	VOPEN	0.2	0.3	0.4	V	VLED= Sweep down
LED Short detection Voltage	VSHORT	4.2	4.5	4.8	V	VOVP= Sweep up
LED Short Latch OFF Delay Time	TSHORT	70	100	130	ms	RT=100k Ω
PWM Latch OFF Delay Time	TPWM	70	100	130	ms	RT=100k Ω
[Logic Inputs (EN, SYNC, PWM, LEDEN)]						
Input HIGH voltage	VINH	2.1	-	5.5	V	
Input LOW voltage	VINL	GND	-	0.8	V	
Input current 1	IIN	20	35	50	μ A	VIN=5V (SYNC, PWM, LEDEN)
Input current 2	IEN	15	25	35	μ A	VEN=5V (EN)
[FAIL Output (open drain)]						
FAIL LOW voltage	VOL	-	0.1	0.2	V	IOL=0.1mA

© This product is not designed for use in radioactive environments.

●Electrical characteristic curves (Reference data)

(unless otherwise specified, Ta=25°C)

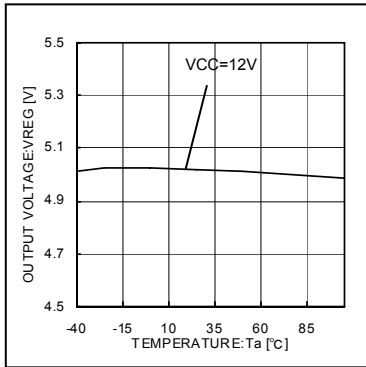

Fig.1 VREG temperature characteristic

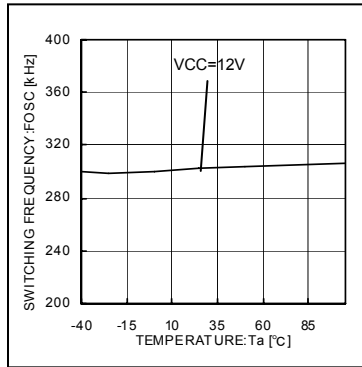

Fig.2 OSC temperature characteristic

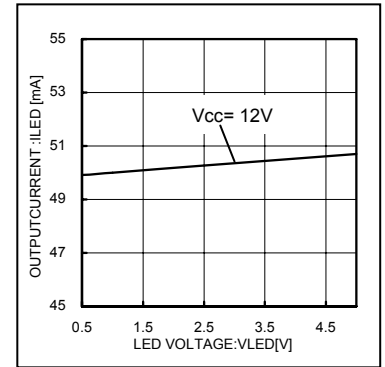

Fig.3 ILED depend on VLED

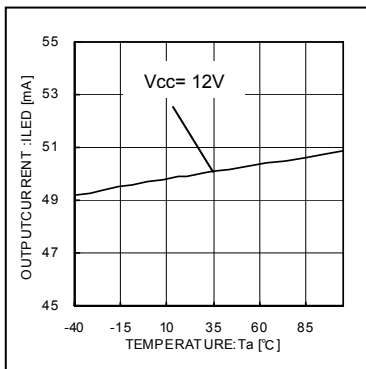

Fig.4 ILED temperature characteristic

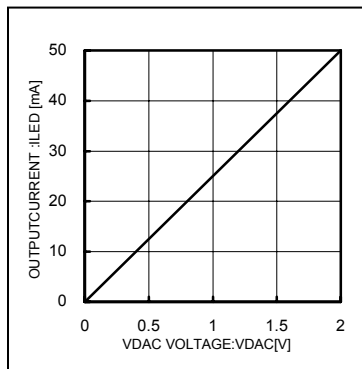

Fig.5 VDAC Gain①

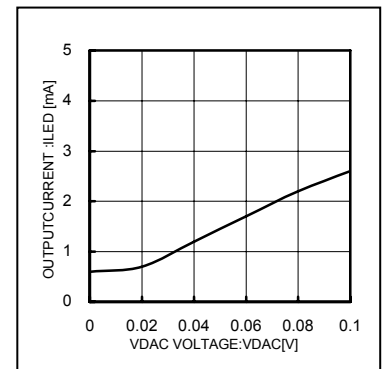

Fig.3 VDAC Gain②

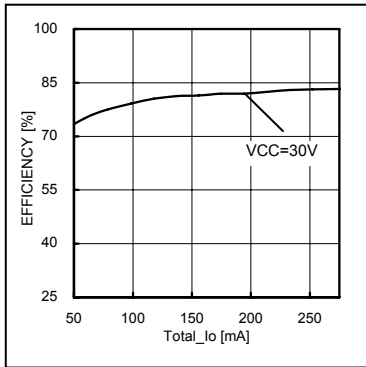

Fig.7 Efficiency (LED2 Parallel 5 step)

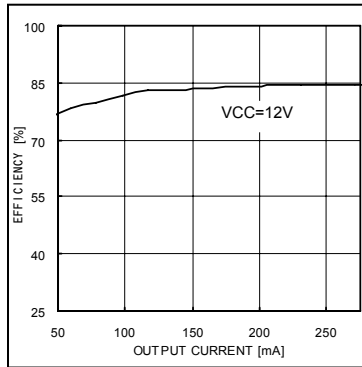

Fig.8 Efficiency (LED2 Parallel 7 step)

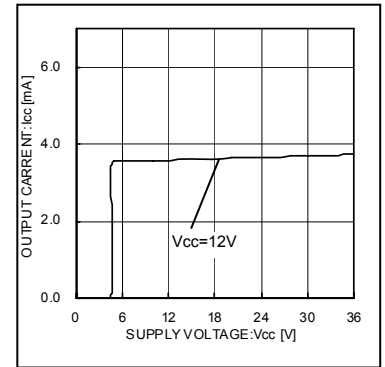

Fig.9 Circuit Current (Switching OFF)

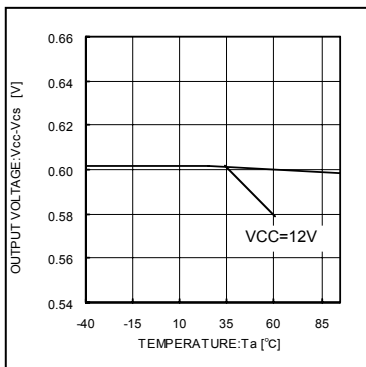

Fig.10 Overcurrent detecting voltage temperature characteristic

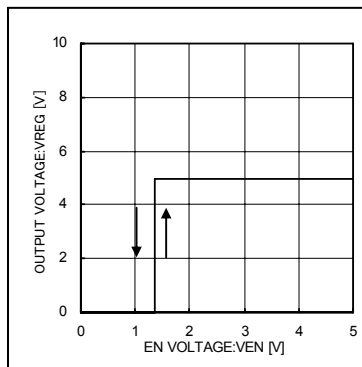

Fig.11 EN threshold voltage

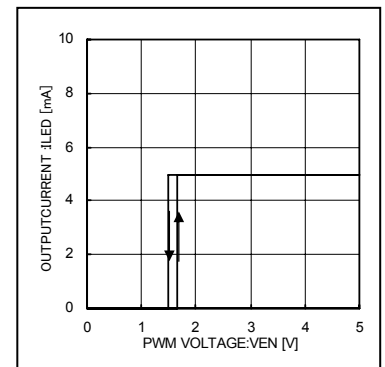
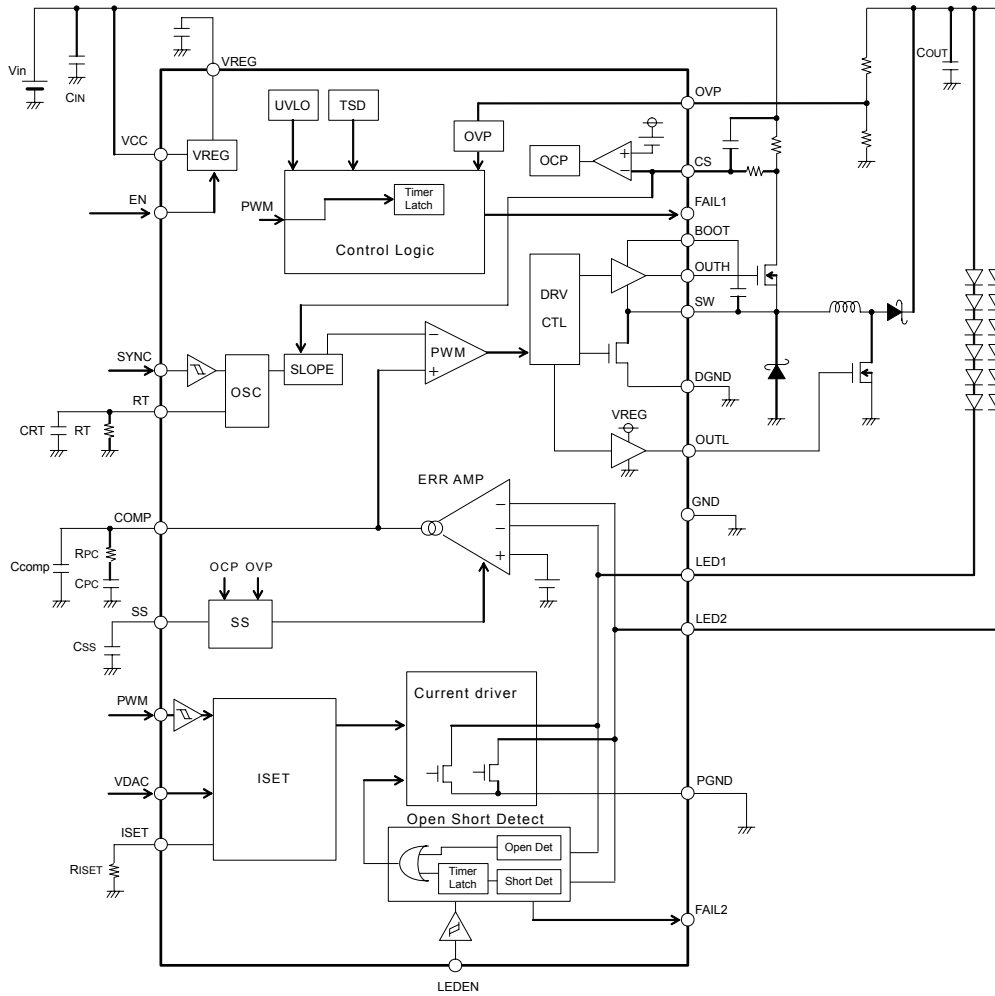

Fig.12 PWM threshold voltage

●Block diagram and pin configuration



● Pin layout

BD8112EFV-M (HTSSOP-B24)

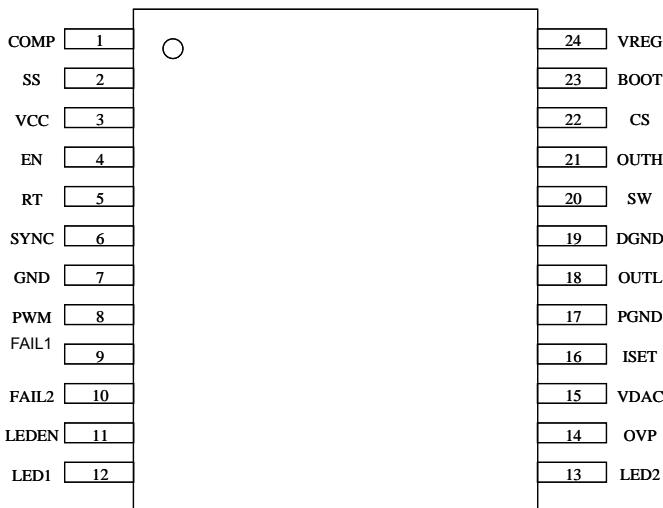

● Pin function table

Pin	Symbol	Function
1	COMP	Error amplifier output
2	SS	Soft start time-setting capacitance input
3	VCC	Input power supply
4	EN	Enable input
5	RT	Oscillation frequency-setting resistance input
6	SYNC	External synchronization signal input
7	GND	Small-signal GND
8	PWM	PWM light modulation input
9	FAIL1	Failure signal output
10	FAIL2	LED open/short detection signal output
11	LEDEN	LED output enable pin
12	LED1	LED output 1
13	LED2	LED output 2
14	OVP	Over-voltage detection input
15	VDAC	DC variable light modulation input
16	ISET	LED output current-setting resistance input
17	PGND	LED output GND
18	OUTL	Low-side external MOSFET Gate Drive out put
19	DGND	Low-side internal MOSFET Source out put
20	SW	High-side external MOSFET Source pin
21	OUTH	High-side external MOSFET Gate Drive out pin
22	CS	DC/DC Current Sense Pin
23	BOOT	High-side MOSFET Power Supply pin
24	VREG	Internal reference voltage output

Fig.14

● **5V voltage reference (VREG)**

5V (Typ.) is generated from the VCC input voltage when the enable pin is set high. This voltage is used to power internal circuitry, as well as the voltage source for device pins that need to be fixed to a logical HIGH.

UVLO protection is integrated into the VREG pin. The voltage regulation circuitry operates uninterrupted for output voltages higher than 4.45 V (Typ.), but if output voltage drops to 4.3 V (Typ.) or lower, UVLO engages and turns the IC off.

Connect a capacitor (Creg = 2.2uF Typ.) to the VREG terminal for phase compensation. Operation may become unstable if Creg is not connected.

● **Constant-current LED drivers**

If less than four constant-current drivers are used, unused channels should be switched off via the LEDEN pin configuration. The truth table for these pins is shown below. If a driver output is enabled but not used (i.e. left open), the IC's open circuit-detection circuitry will operate. Please keep the unused pins open. The LEDEN terminals are pulled down internally in the IC, so if left open, the IC will recognize them as logic LO. However, they should be connected directly to VREG or fixed to a logic HI when in use.

LED EN	LED	
	1	2
L	ON	ON
H	ON	OFF

▪ **Output current setting**

LED current is computed via the following equation:

$$I_{LED} = \min[VDAC, VISET(=2.0V)] / RSET \times GAIN [A]$$

(min[VDAC, 2.0V] = the smaller value of either VDAC or VISET; GAIN = set by internal circuitry.)

In applications where an external signal is used for output current control, a control voltage in the range of 0.0 to 2.0 V can be connected on the VDAC pin to control according to the above equation. If an external control signal is not used, connect the VDAC pin to VREG (do not leave the pin open as this may cause the IC to malfunction). Also, do not switch individual channels on or off via the LEDEN pin while operating in PWM mode.

The following diagram illustrates the relation between ILED and GAIN.

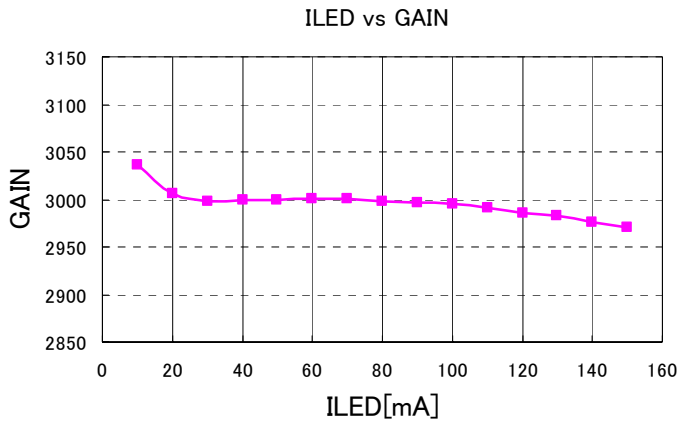

In PWM intensity control mode, the ON/OFF state of each current driver is controlled directly by the input signal on the PWM pin; thus, the duty ratio of the input signal on the PWM pin equals the duty ratio of the LED current. When not controlling intensity via PWM, fix the PWM terminal to a high voltage (100%). Output light intensity is greatest at 100% input.

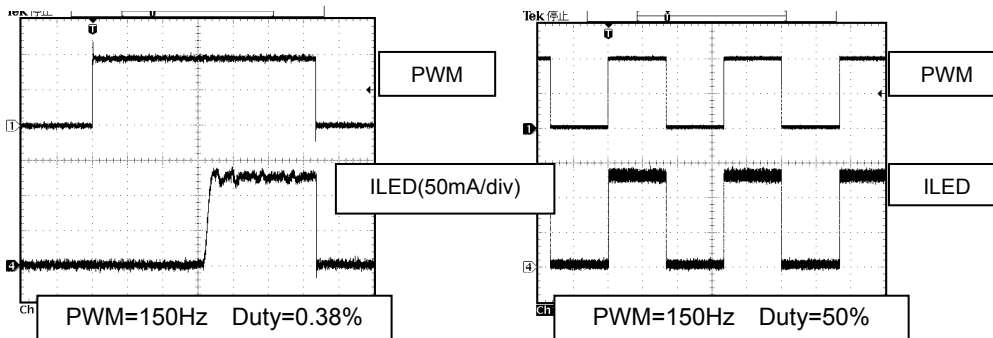

- **Buck-Boost DC/DC controller**

- **Number of LEDs in series connection**

Output voltage of the DCDC converter is controlled such that the forward voltage over each of the LEDs on the output is set to 1.0V (Typ.). DCDC operation is performed only when the LED output is operating. When two or more LED outputs are operating simultaneously, the LED voltage output is held at 1.0V (Typ.) per LED over the column of LEDs with the highest VF value. The voltages of other LED outputs are increased only in relation to the fluctuation of voltage over this column. Consideration should be given to the change in power dissipation due to variations in VF of the LEDs. Please determine the allowable maximum VF variance of the total LEDs in series by using the description as shown below:

VF variation allowable voltage 3.7V (Typ.)

= short detecting voltage 4.5V (Typ.) – LED control voltage 1.0V (Typ.)

The number of LEDs that can be connected in series is limited due to the open-circuit protection circuit, which engages at 85% of the set OVP voltage. Therefore, the maximum output voltage of the under normal operation becomes **30.6 V** (= **36 V** x **0.85**, where **(30.6 V – 1.0 V) / VF > N** [maximum number of LEDs in series]).

- **Over-voltage protection circuit (OVP)**

The output of the DCDC converter should be connected to the OVP pin via a voltage divider. In determining an appropriate trigger voltage of for OVP function, consider the total number of LEDs in series and the maximum variation in VF. Also, bear in mind that over-current protection (OCP) is triggered at 0.85 x OVP trigger voltage. If the OVP function engages, it will not release unless the DCDC voltage drops to 72.5% of the OVP trigger voltage. For example, if ROVP1 (out put voltage side), ROVP2 (GND side), and DCDC voltage VOUT are conditions for OVP, then: **VOUT ≥ (ROVP1 + ROVP2) / ROVP2 x 2.0 V**. OVP will engage when **VOUT ≥ 32 V** if **ROVP1 = 330 kΩ** and **ROVP2 = 22 kΩ**.

- **Buck-boost DC/DC converter oscillation frequency (FOSC)**

The regulator's internal triangular wave oscillation frequency can be set via a resistor connected to the RT pin (pin 5). This resistor determines the charge/discharge current to the internal capacitor, thereby changing the oscillating frequency. Refer to the following theoretical formula when setting RT:

$$f_{osc} = \frac{30 \times 10^6}{RT [\Omega]} \times \alpha \text{ [kHz]}$$

30×10^6 (V/A/S) is a constant ($\pm 5\%$) determined by the internal circuitry, and α is a correction factor that varies in relation to RT:

{ RT: $\alpha = 50\text{k}\Omega: 0.94, 60\text{k}\Omega: 0.985, 70\text{k}\Omega: 0.99, 80\text{k}\Omega: 0.994, 90\text{k}\Omega: 0.996, 100\text{k}\Omega: 1.0, 150\text{k}\Omega: 1.01, 200\text{k}\Omega: 1.02, 300\text{k}\Omega: 1.03, 400\text{k}\Omega: 1.04, 500\text{k}\Omega: 1.045$ }

A resistor in the range of 47kΩ~523kΩ is recommended. Settings that deviate from the frequency range shown below may cause switching to stop, and proper operation cannot be guaranteed.

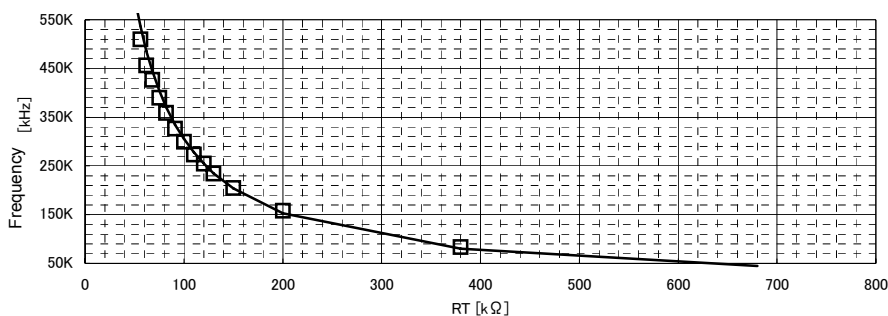

Fig.15 RT versus switching frequency

- **External DC/DC converter oscillating frequency synchronization (FSYNC)**

Do not switch from external to internal oscillation of the DC/DC converter if an external synchronization signal is present on the SYNC pin. When the signal on the SYNC terminal is switched from high to low, a delay of about 30 μs (typ.) occurs before the internal oscillation circuitry starts to operate (only the rising edge of the input clock signal on the SYNC terminal is recognized). Moreover, if external input frequency is less than the internal oscillation frequency, the internal oscillator will engage after the above-mentioned 30 μs (typ.) delay; thus, do not input a synchronization signal with a frequency less than the internal oscillation frequency.

- **Soft Start Function**

The soft-start (SS) limits the current and slows the rise-time of the output voltage during the start-up, and hence leads to prevention of the overshoot of the output voltage and the inrush current.

• Self-diagnostic functions

The operating status of the built-in protection circuitry is propagated to FAIL1 and FAIL2 pins (open-drain outputs). FAIL1 becomes low when UVLO, TSD, OVP, or SCP protection is engaged, whereas FAIL2 becomes low when open or short LED is detected.

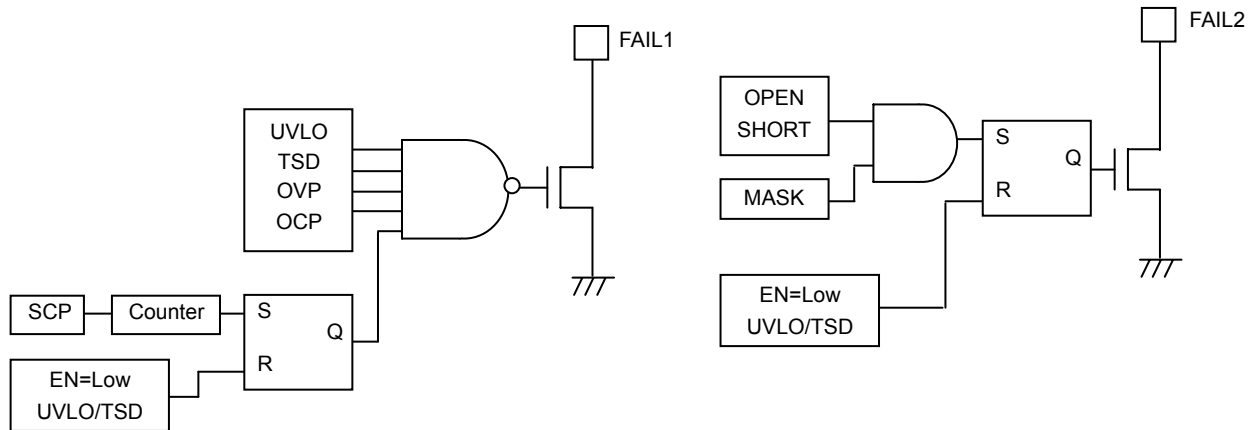

• Operation of the Protection Circuitry

- Under-Voltage Lock Out (UVLO)

The UVLO shuts down all the circuits other than REG when $V_{REG} \leq 4.3V$ (TYP).
- Thermal Shut Down (TSD)

The TSD shuts down all the circuits other than REG when the T_j reaches $175^\circ C$ (TYP), and releases when the T_j becomes below $150^\circ C$ (TYP).
- Over Current Protection (OCP)

The OCP detects the current through the power-FET by monitoring the voltage of the high-side resistor, and activates when the CS voltage becomes less than $V_{CC}-0.6V$ (TYP).
When the OCP is activated, the external capacitor of the SS pin becomes discharged and the switching operation of the DCDC turns off.
- Over Voltage Protection (OVP)

The output voltage of the DCDC is detected with the OVP-pin voltage, and the protection activates when the OVP-pin voltage becomes greater than $2.0V$ (TYP).
When the OVP is activated, the external capacitor of the SS pin becomes discharged and the switching operation of the DCDC turns off.

• Short Circuit Protection (SCP)

When the LED-pin voltage becomes less than $0.3V$ (TYP), the internal counter starts operating and latches off the circuit approximately after $100ms$ (when $F_{OSC} = 300kHz$). If the LED-pin voltage becomes over $0.3V$ before $100ms$, then the counter resets.

When the LED anode (i.e. DCDC output voltage) is shorted to ground, then the LED current becomes off and the LED-pin voltage becomes low. Furthermore, the LED current also becomes off when the LED cathode is shorted to ground. Hence in summary, the SCP works with both cases of the LED anode and the cathode being shorted.

• LED Open Detection

When the LED-pin voltage $\leq 0.3V$ (TYP) as well as OVP-pin voltage $\geq 1.7V$ (TYP) simultaneously, the device detects as LED open and latches off that particular channel.

• LED Short Detection

When the LED-pin voltage $\geq 4.5V$ (TYP) as well as OVP-pin voltage $\leq 1.6V$ (TYP) simultaneously the internal counter starts operating, and approximately after 100ms (when FOSC = 300kHz) the only detected channel (as LED short) latches off. With the PWM brightness control, the detecting operation is processed only when PWM-pin = High. If the condition of the detection operation is released before 100ms (when FOSC = 300kHz), then the internal counter resets.

※ The counter frequency is the DCDC switching frequency determined by the RT. The latch proceeds at the count of 32770.

Protection	Detecting Condition		Operation after detect
	[Detect]	[Release]	
UVLO	VREG<4.3V	VREG>4.45V	All blocks (but except REG) shut down
TSD	Tj>175°C	Tj<150°C	All blocks (but except REG) shut down
OVP	VOVP>2.0V	VOVP<1.45V	SS discharged
OCP	VCS \leq VCC-0.6V	VCS>VCC-0.6V	SS discharged
SCP	VLED<0.3V (100ms delay when FOSC=300kHz)	EN or UVLO	Counter starts and then latches off all blocks (but except REG)
LED open	VLED<0.3V & VOVP>1.7V	EN or UVLO	The only detected channel latches off
LED short	VLED>4.5V & VOVP<1.6V (100ms delay when FOSC=300kHz)	EN or UVLO	The only detected channel latches off (after the counter sets)

●Protection Sequence

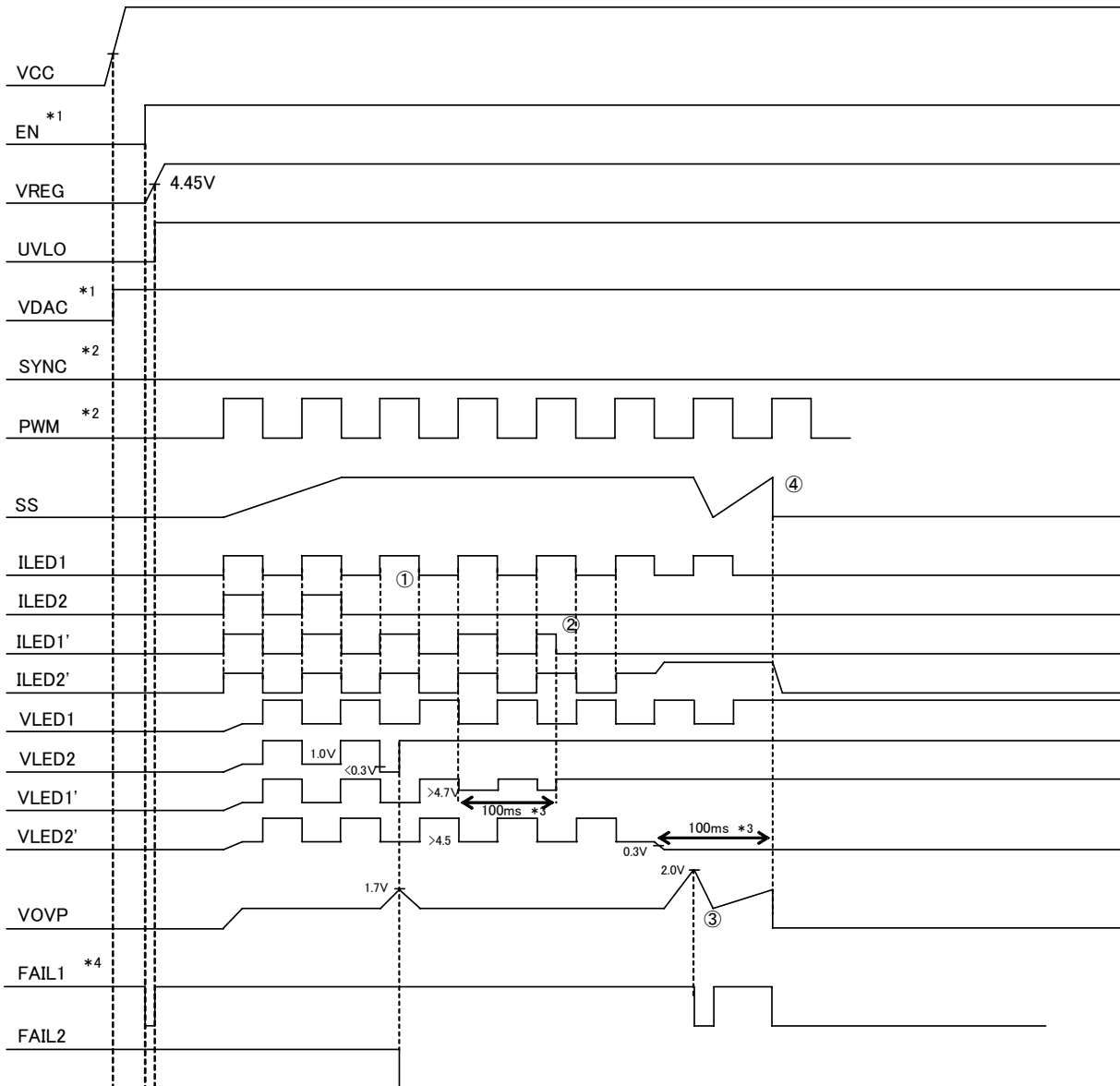

- * 1 After VCC voltage reached to operating conditions, set VDAC voltage, and turn on the EN. After $V_{REG} \geq 4.6V$, turn on SYNC and PWM inputs.
 - * 2 Don't care input sequence PWM and SYNC.
 - * 3 Aprox 100ms of delay when $F_{osc} = 300kHz$
 - * 4 When FAIL1 pull-up to outside power supply.
- ① Case for LED2 in open-mode
When $V_{LED2} < 0.3V$ and $VOVP > 1.7V$ simultaneously, then LED2 becomes off and FAIL2 becomes low
 - ② Case for LED1' in short-mode
When $V_{LED1'} > 4.5V$ and $VOVP < 1.6V$ simultaneously, then LED1' becomes off after 100ms approx
 - ③ Case for LED2' in short to GND
 - ③-1 DCDC output voltage increases, and then SS discharges and FAIL1 becomes low
 - ③-2 Detects $V_{LED2'} < 0.3V$ and shuts down after 100ms approx

● Procedure for external components selection

Follow the steps as shown below for selecting the external components

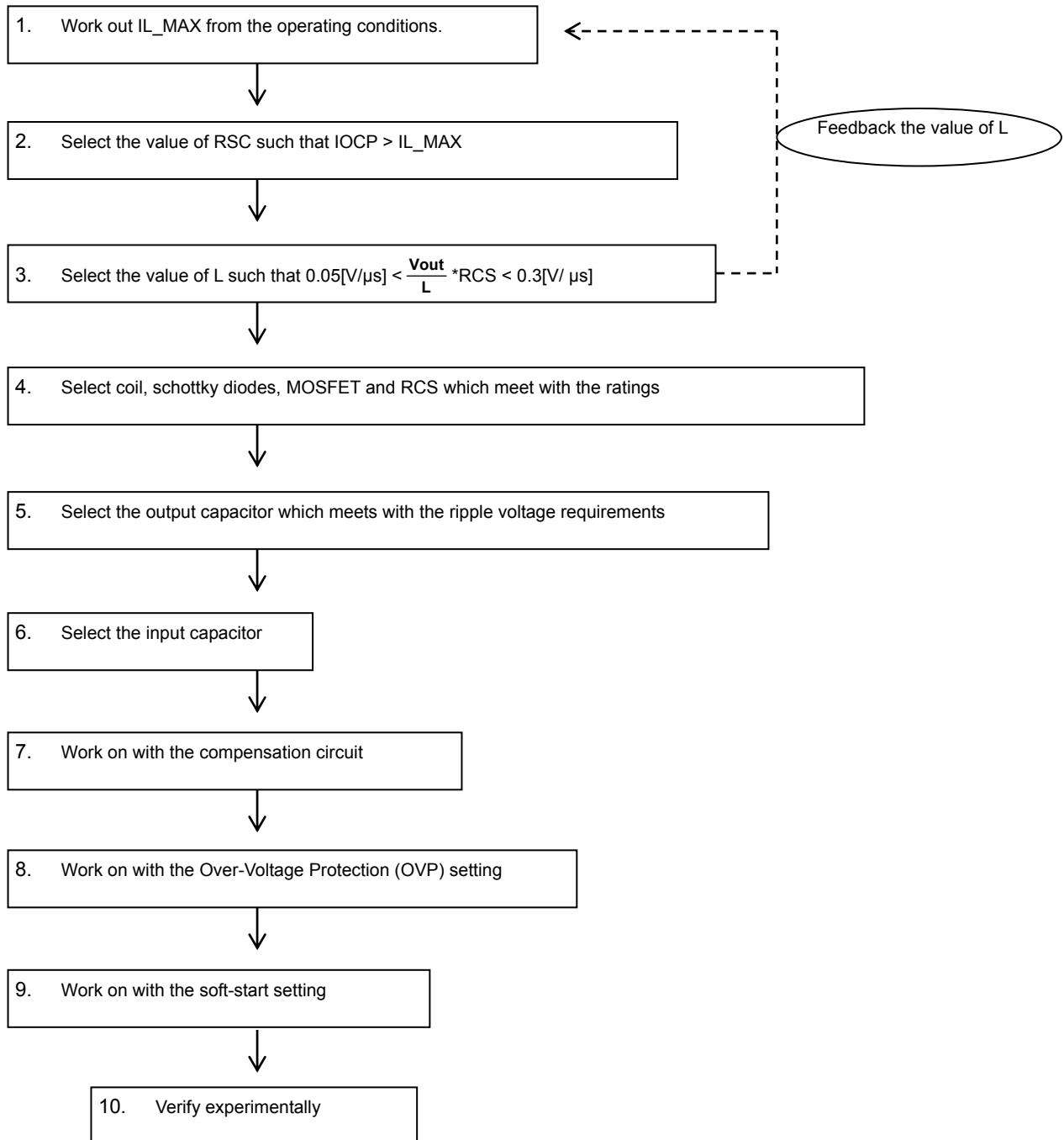

1. Computation of the Input Peak Current and IL_MAX

① Calculation of the maximum output voltage (Vout_max)

To calculate the Vout_max, it is necessary to take into account of the VF variation and the number of LED connection in series.

$$V_{out_max} = (V_F + \Delta V_F) \times N + 1.0V$$

ΔV_F : VF Variation N: Number of LED connection in series

② Calculation of the output current Iout

$$I_{out} = I_{LED} \times 1.05 \times M$$

M : Number of LED connection in parallel

③ Calculation of the input peak current IL_MAX

$$I_{L_MAX} = I_{L_AVG} + 1/2 \Delta I_L$$

$$I_{L_AVG} = (V_{IN} + V_{out}) \times I_{out} / (n \times V_{IN})$$

$$\Delta I_L = \frac{V_{IN}}{L} \times \frac{1}{F_{osc}} \times \frac{V_{out}}{V_{IN} + V_{out}}$$

n: efficiency Fosc: switching frequency

- The worst case scenario for VIN is when it is at the minimum, and thus the minimum value should be applied in the equation.
- The L value of 10μF ~ 47μF is recommended. The current-mode type of DC/DC conversion is adopted for BD8112EFV-M, which is optimized with the use of the recommended L value in the design stage. This recommendation is based upon the efficiency as well as the stability. The L values outside this recommended range may cause irregular switching waveform and hence deteriorate stable operation.
- n (efficiency) is approximately 80%

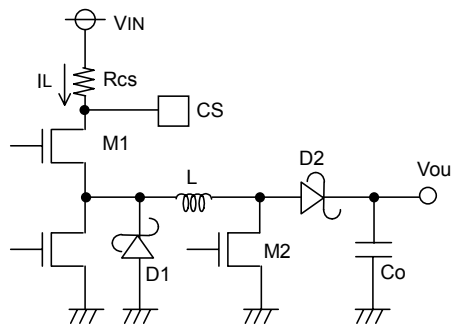

External Application Circuit

2. The setting of over-current protection

Choose Rcs with the use of the equation $V_{ocp_min} (=0.54V) / R_{cs} > I_{L_MAX}$

When investigating the margin, it is worth noting that the L value may vary by approximately ±30%.

3. The selection of the L

In order to achieve stable operation of the current-mode DC/DC converter, we recommend selecting the L value in the range indicated below:

$$0.05 [V/\mu s] < \frac{V_{out} \times R_{cs}}{L} < 0.3 [V/\mu s]$$

The smaller $\frac{V_{out} \times R_{cs}}{L}$ allows stability improvement but slows down the response time.

4. Selection of coil L, diode D1 and D2, MOSFET M1 and M2, and Rcs

	Current rating	Voltage rating	Heat loss
Coil L	> IL_MAX	—	
Diode D1	> Iocp	> VIN_MAX	
Diode D2	> Iocp	> Vout	
MOSFET M1	> Iocp	> VIN_MAX	
MOSFET M2	> Iocp	> Vout	
Rcs	—	—	> Iocp ² × Rcs

※ Allow some margin, such as the tolerance of the external components, when selecting.

※ In order to achieve fast switching, choose the MOSFETs with the smaller gate-capacitance.

5. Selection of the output capacitor

Select the output capacitor C_{out} based on the requirement of the ripple voltage V_{pp} .

$$V_{pp} = \frac{I_{out}}{C_{out}} \times \frac{V_{out}}{V_{out}+V_{IN}} \times \frac{1}{F_{osc}} + I_{L_MIN} \times RESR$$

Choose C_{out} that allows the V_{pp} to settle within the requirement. Allow some margin also, such as the tolerance of the external components.

6. Selection of the input capacitor

A capacitor at the input is also required as the peak current flows between the input and the output in DC/DC conversion. We recommend an input capacitor greater than $10\mu\text{F}$ with the ESR smaller than $100\text{m}\Omega$. The input capacitor outside of our recommendation may cause large ripple voltage at the input and hence lead to malfunction.

7. Phase Compensation Guidelines

In general, the negative feedback loop is stable when the following condition is met:

- Overall gain of 1 (0dB) with a phase lag of less than 150° (i.e., a phase margin of 30° or more)

However, as the DC/DC converter constantly samples the switching frequency, the gain-bandwidth (GBW) product of the entire series should be set to 1/10 the switching frequency of the system. Therefore, the overall stability characteristics of the application are as follows:

- Overall gain of 1 (0dB) with a phase lag of less than 150° (i.e., a phase margin of 30° or more)
- GBW (frequency at gain 0dB) of 1/10 the switching frequency

Thus, to improve response within the GBW product limits, the switching frequency must be increased.

The key for achieving stability is to place f_z near to the GBW.

$$\text{Phase-lead } f_z = \frac{1}{2\pi C_{pc}R_{pc}} \text{ [Hz]}$$

$$\text{Phase-lag } f_{p1} = \frac{1}{2\pi R_L C_{out}} \text{ [Hz]}$$

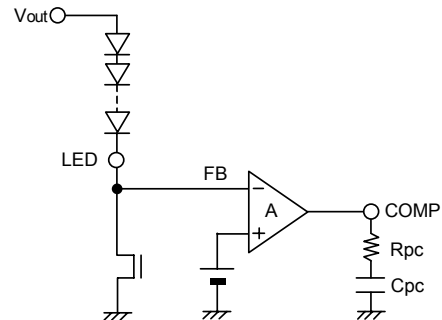

Good stability would be obtained when the f_z is set between $1\text{kHz} \sim 10\text{kHz}$.

In buck-boost applications, Right-Hand-Plane (RHP) Zero exists. This Zero has no gain but a pole characteristic in terms of phase. As this Zero would cause instability when it is in the control loop, so it is necessary to bring this zero before the GBW.

$$f_{RHP} = \frac{V_{out}+V_{IN}}{2\pi I_{LOAD}L} \text{ [Hz]} \quad I_{LOAD}: \text{ MAXIMUM LOAD CURRENT}$$

It is important to keep in mind that these are very loose guidelines, and adjustments may have to be made to ensure stability in the actual circuitry. It is also important to note that stability characteristics can change greatly depending on factors such as substrate layout and load conditions. Therefore, when designing for mass-production, stability should be thoroughly investigated and confirmed in the actual physical design.

8. Setting of the over-voltage protection

We recommend setting the over-voltage protection V_{ovp} 1.2V to 1.5V greater than V_{out} which is adjusted by the number of LEDs in series connection. Less than 1.2V may cause unexpected detection of the LED open and short during the PWM brightness control. For the V_{ovp} greater than 1.5V, the LED short detection may become invalid.

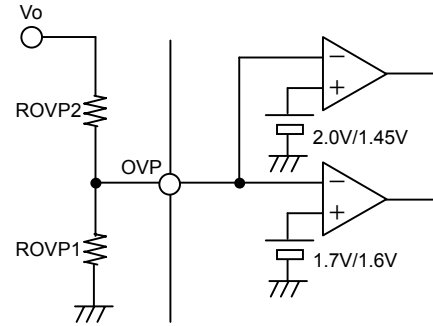

9. Setting of the soft-start

The soft-start allows minimization of the coil current as well as the overshoot of the output voltage at the start-up.

For the capacitance we recommend in the range of 0.001 ~ 0.1 μ F. For the capacitance less than 0.001 μ F may cause overshoot of the output voltage. For the capacitance greater than 0.1 μ F may cause massive reverse current through the parasitic elements of the IC and damage the whole device. In case it is necessary to use the capacitance greater than 0.1 μ F, ensure to have a reverse current protection diode at the Vcc or a bypass diode placed between the SS-pin and the Vcc.

Soft-start time TSS

$$TSS = CSS \times 0.7V / 5\mu A [s]$$

CSS: The capacitance at the SS-pin

10. Verification of the operation by taking measurements

The overall characteristic may change by load current, input voltage, output voltage, inductance, load capacitance, switching frequency, and the PCB layout. We strongly recommend verifying your design by taking the actual measurements.

● Power Dissipation Calculation

Power dissipation can be calculated as follows:

$$P_c(N) = I_{CC} \cdot V_{CC} + 2 \cdot C_{iss} \cdot V_{REG} \cdot F_{sw} \cdot V_{cc} + [V_{LED} \cdot N + \Delta V_f \cdot (N-1)] \cdot I_{LED}$$

- I_{CC} Maximum circuit current
- V_{CC} Supply power voltage
- C_{iss} External FET capacitance
- V_{sw} SW gate voltage
- F_{sw} SW frequency
- V_{LED} LED control voltage
- N LED parallel numeral
- ΔV_f LED V_f fluctuation
- I_{LED} LED output current

Sample Calculation:

$$P_c(2) = 10\text{mA} \times 30\text{V} + 500\text{pF} \times 5\text{V} \times 300\text{kHz} \times 30\text{V} + [1.0\text{V} \times 2 + \Delta V_f \times 1] \times 100\text{mA}$$

When $\Delta V_f = 3.0\text{V}$, $P_c(2) = 0.82\text{W}$

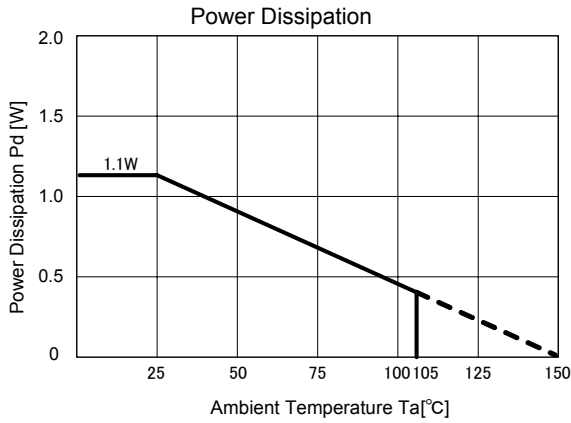

Fig.26

Note 1: Power dissipation calculated when mounted on 70mm X 70mm X 1.6mm glass epoxy substrate (1-layer platform/copper thickness 18 μ m)

Note 2: Power dissipation changes with the copper foil density of the board. This value represents only observed values, not guaranteed values.

●How to select parts of application

serial No.	component name	component value	product name	Manufacturer
1	CIN1	10 μ F	GRM31CB31E106KA75B	murata
2	CIN2	—		
3	CIN3	—		
4	CPC1	0.1 μ F		
5	CPC2	—		murata
6	RPC1	510 Ω		
7	CSS	0.1 μ F	GRM188B31H104KA92	murata
8	RRT	100k Ω	MCR03 Series	Rohm
9	CRT	—		
10	RFL1	100k Ω	MCR03 Series	Rohm
11	RFL2	100k Ω	MCR03 Series	Rohm
12	CCS	—		
13	RCS1	620m Ω	MCR100JZHFSR620	Rohm
14	RCS2	620m Ω	MCR100JZHFSR620	Rohm
15	RCS3	—		
16	RCS5	0 Ω		
17	CREG	2.2 μ F	GRM188B31A225KE33	murata
18	CBT	0.1 μ F	GRM188B31H104KA92	murata
19	M1	—	RSS070N05	Rohm
20	M2	—	RSS070N05	Rohm
21	D1	—	RB050L-40	Rohm
22	D2	—	RF201L2S	Rohm
23	L1	33 μ H	CDRH105R330	Sumida
24	COUT1	10 μ F	GRM31CB31E106KA75B	murata
25	COUT2	10 μ F	GRM31CB31E106KA75B	murata
26	ROVP1	30k Ω	MCR03 Series	Rohm
27	ROVP2	360k Ω	MCR03 Series	Rohm
28	RISSET	120k Ω	MCR03 Series	Rohm
29	CISSET	—		
30	RDAC	0 Ω		

When performing open/short tests of the external components, the open condition of D1 or D2 may cause permanent damage to the driver and/or the external components. In order to prevent this, we recommend having parallel connections for D1 and D2.

● Interfaces ● Input/output Equivalent Circuits (terminal name follows pin number)

<p>1. COMP</p>	<p>2. SS</p>	<p>4. EN</p>
<p>5. RT</p>	<p>6. SYNC, 8. PWM</p>	<p>9. FAIL1, 10. FAIL2</p>
<p>11. LEDEN</p>	<p>12. LED1, 13. LED2</p>	<p>14. OVP</p>
<p>15. VDACC</p>	<p>16. ISET</p>	<p>18. OUTL</p>
<p>20. SW</p>	<p>21. OUTH</p>	<p>22. CS</p>
<p>23. BOOT</p>	<p>24. VREG</p>	

※All values typical.

●Notes for use

1. Absolute maximum ratings

We are careful enough for quality control about this IC. So, there is no problem under normal operation, excluding that it exceeds the absolute maximum ratings. However, this IC might be destroyed when the absolute maximum ratings, such as impressed voltages or the operating temperature range(T_{opr}), is exceeded, and whether the destruction is short circuit mode or open circuit mode cannot be specified. Please take into consideration the physical countermeasures for safety, such as fusing, if a particular mode that exceeds the absolute maximum rating is assumed.

2. Reverse polarity connection

Connecting the power line to the IC in reverse polarity (from that recommended) will damage the part. Please utilize the direction protection device as a diode in the supply line.

3. Power supply line

Due to return of regenerative current by reverse electromotive force, using electrolytic and ceramic suppress filter capacitors ($0.1\mu\text{F}$) close to the IC power input terminals (V_{cc} and GND) are recommended. Please note the electrolytic capacitor value decreases at lower temperatures and examine to dispense physical measures for safety.

And, for ICs with more than one power supply, it is possible that rush current may flow instantaneously due to the internal powering sequence and delays. Therefore, give special consideration to power coupling capacitance, width of power wiring, GND wiring, and routing of wiring. Please make the power supply lines (where large current flow) wide enough to reduce the resistance of the power supply patterns, because the resistance of power supply pattern might influence the usual operation.

4. GND line

The ground line is where the lowest potential and transient voltages are connected to the IC.

5. Thermal design

Do not exceed the power dissipation (P_d) of the package specification rating under actual operation, and please design enough temperature margins.

6. Short circuit mode between terminals and wrong mounting

Do not mount the IC in the wrong direction and be careful about the reverse-connection of the power connector. Moreover, this IC might be destroyed when the dust short the terminals between them or power supply, GND.

7. Radiation

Strong electromagnetic radiation can cause operation failures.

8. ASO(Area of Safety Operation.)

Do not exceed the maximum ASO and the absolute maximum ratings of the output driver.

9. TSD(Thermal shut-down)

The TSD is activated when the junction temperature (T_j) reaches 175°C (with 25°C hysteresis), and the output terminal is switched to Hi-z. The TSD circuit aims to intercept IC from high temperature. The guarantee and protection of IC are not purpose. Therefore, please do not use this IC after TSD circuit operates, nor use it for assumption that operates the TSD circuit.

10. Inspection by the set circuit board

The stress might hang to IC by connecting the capacitor to the terminal with low impedance. Then, please discharge electricity in each and all process. Moreover, in the inspection process, please turn off the power before mounting the IC, and turn on after mounting the IC. In addition, please take into consideration the countermeasures for electrostatic damage, such as giving the earth in assembly process, transportation or preservation.

11. IC terminal input

This IC is a monolithic IC, and has P^+ isolation and P substrate for the element separation. Therefore, a parasitic PN junction is formed in this P-layer and N-layer of each element. For instance, the resistor or the transistor is connected to the terminal as shown in the figure below. When the GND voltage potential is greater than the voltage potential at Terminals A or B, the PN junction operates as a parasitic diode. In addition, the parasitic NPN transistor is formed in said parasitic diode and the N layer of surrounding elements close to said parasitic diode. These parasitic elements are formed in the IC because of the voltage relation. The parasitic element operating causes the wrong operation and destruction. Therefore, please be careful so as not to operate the parasitic elements by impressing to input terminals lower voltage than GND(P substrate). Please do not apply the voltage to the input terminal when the power-supply voltage is not impressed. Moreover, please impress each input terminal lower than the power-supply voltage or equal to the specified range in the guaranteed voltage when the power-supply voltage is impressing.

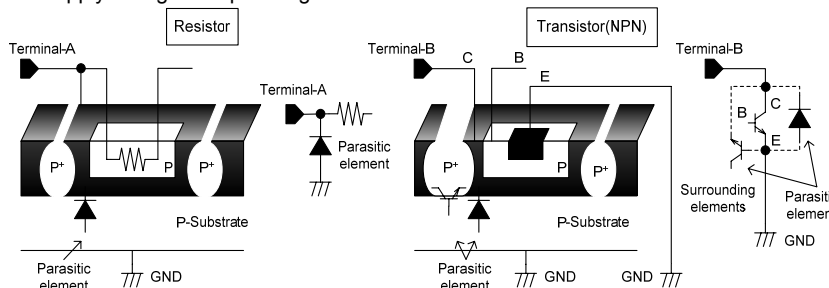

Simplified structure of IC

12. Earth wiring pattern

Use separate ground lines for control signals and high current power driver outputs. Because these high current outputs that flows to the wire impedance changes the GND voltage for control signal. Therefore, each ground terminal of IC must be connected at the one point on the set circuit board. As for GND of external parts, it is similar to the above-mentioned.

